

# VOYAGER 2™

CARPET EXTRACTOR

Operating Instructions (GB/USA)

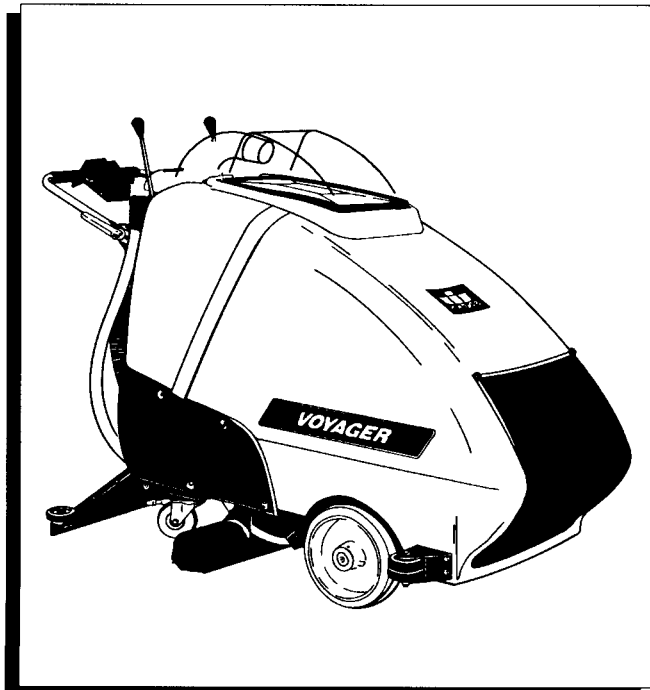

MODEL  
**VGR2**

POWER SOURCE  
**BATTERY**

Beginning with Serial# 1000081028

**QUEST**® . . . for Continuous Improvement.  
Windsor's Quality Management System is Certified ISO 9001.

*Read instructions before operating the machine.*

WWW.MANUALS.WS

# MACHINE DATA LOG/TABLE OF CONTENTS

MODEL - \_\_\_\_\_

DATE OF PURCHASE - \_\_\_\_\_

SERIAL NUMBER - \_\_\_\_\_

SALES REPRESENTATIVE - \_\_\_\_\_

DISTRIBUTOR NAME - \_\_\_\_\_

©Copyright 2001 Windsor Industries, Printed in U.S.A.

## TABLE OF CONTENTS

<i>Data Log / Table of Contents</i> .....	2	<i>Propel Handle Assembly</i> .....	14
<i>Technical Specifications</i> .....	3	<i>Drive and Brush Assembly</i> .....	16
<i>Safety Precautions</i> .....	4	<i>Pump, Vac, Manifold and Brush Motor Assemblies</i> .....	18
<i>Battery Installation &amp; Removal</i> .....	5	<i>Rear Tower Electrical Assemblies</i> .....	20
<i>Battery Information</i> .....	6	<i>Handle, Microswitch and Cable Assemblies</i> .....	22
<i>Operation Controls</i> .....	7	<i>Control Panel Assemblies</i> .....	24
<i>Operations</i> .....	8	<i>Vac Shoe Assembly</i> .....	26
<i>Accessory Tools and Maintenance</i> .....	9	<i>Tank, Cover and Hardware</i> .....	28
<i>Maintenance</i> .....	10	<i>Wiring Diagram</i> .....	30
<i>Service Schedule</i> .....	13	<i>Warranty</i> .....	31

WWW.MANUALS.WS

## TECHNICAL SPECIFICATIONS

ITEM	MEASURE
Electric Propelling Motor	(1)-1/4 hp DC (186 watts) with solid state variable speed forward and reverse with safety shut-off.
Electric Vacuum Motors	(2)- 3 stage, 1.3 hp (970 watts), 5.7 inch (14.5cm) diameter motors in parallel, provide 152 cfm (4.25m <sup>3</sup> /min.), 74 inches (188 cm) water lift total. Electric shut-off.
Electric Brush Motors	(1)- 0.4 hp (298 watts) permanent magnet, DC.
Electrical	36 Volt DC
Batteries	(3)- 12 volt, @ 185 A/H, in a (Optional) removable battery pack.
Solution Pump	100 PSI, diaphragm style pump
Cleaning Speed	Variable speeds from 0-130 ft/min (39.6m/min) Transport 0-130; Cleaning 0-110
Solution Capacity	40 gallons (151 ltr)
Recovery Capacity	35 gallons (132 ltr)
Brush Speed	1000 RPM
Vacuum Shoe	28" (71 cm) wide, cast aluminum, tension pulley adj., floating and pivoting.
Wheels:	
Front: (2)	10" dia. (25 cm) by 2.5" wide (6.4 cm)
Rear: (2)	4" dia. (10 cm) casters
Weight:	
Empty:	240 lbs. (109 kg)
W/ Batteries	645 lbs. (260 kg)
Length	60" (152 cm)
Storage Position	52" (132 cm)
Height	43" (109 cm)
Width	30" (76 cm)

**SIDE VIEW**

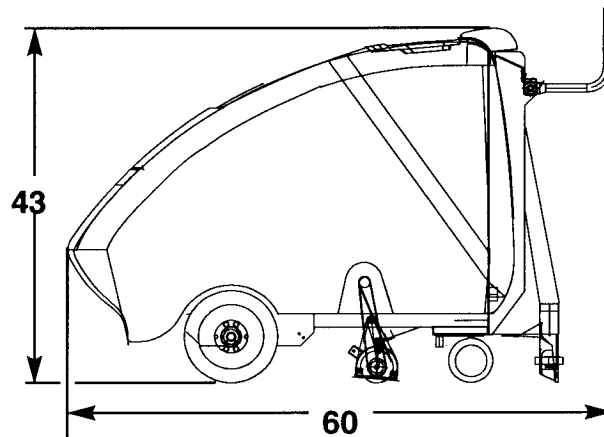

**TOP VIEW**

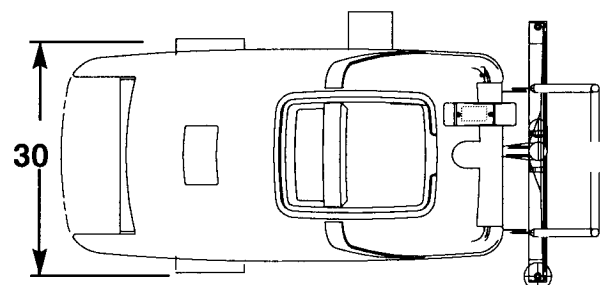

# IMPORTANT SAFETY INSTRUCTIONS

When using a battery powered appliance, basic precaution must always be followed, including the following:

**READ ALL INSTRUCTIONS BEFORE USING THIS MACHINE.**



## **WARNING:**

To reduce the risk of fire, electric shock, or injury:

Do not use outdoors or expose to moisture.

Do not operate in standing water.

Machines can cause a fire when operated near flammable vapors or materials. Do not operate this machine near flammable fluids, dust, vapors or gas. Do not pickup burning materials such as cigarettes or matches.

Operate this machine only from the rear of the machine.

Maintenance and repairs must be done by qualified personnel.

Store machine inside. Keep the electrical components of the machine dry.

Wear eye protection when working near batteries. Do not put any type of metal objects across the battery terminals or on top of the batteries.

Lead acid batteries generate gasses which can cause an explosion. Keep sparks and flames away from the batteries. Charge the batteries only in well ventilated area.

Make sure all warning and caution labels are legible and properly attached to the machine.

Maintain adjustments on machine as per specifications noted in the owner's guide.

## **SAVE THESE INSTRUCTIONS**

### **IMPORTANT SHIPPING NOTE**

Carefully unpack your Voyager and inspect it for shipping damage. Any damages which occurred during shipping are the responsibility of the carrier, who must be notified immediately.

WWW.MANUALS.WS

## BATTERY INSTALLATION & REMOVAL (W/ BATTERY CART)



### WARNING:

WEAR EYE PROTECTION AND PROTECTIVE CLOTHING WHEN WORKING WITH BATTERIES.

#### BATTERY INSTALLATION AND REMOVAL



### CAUTION:

FOLLOW THE PROCEDURES CAREFULLY.

1. Remove the vac shoe hose from tank, lay dome back and slowly open tank to upright position.
2. Install (3) batteries in machine by placing them in battery tray liner provided. (See diagram page 6)
3. Connect battery wires according to diagram on page 6.

#### INSTALLATION OF BATTERIES



### CAUTION:

FOLLOW PROCEDURES CAREFULLY, BE SURE TO KEEP HANDS AND FEET CLEAR FROM ROLLING BATTERY TRAY.

1. Make sure the battery door is open. **A**
2. Roll the Battery Cart up to the front of the machine, (aligning the front of the two frames). **B**
3. Push the cart until the latches lock into the tabs on the front of the machine frame. **C**
4. Pull the handle on the Battery Tray. (This releases the locking mechanism on the cart.) Fig 1 & 2 **D**
5. Push the batteries into the machine until the locking mechanism on the frame is engaged. (This can be heard by a "Snapping" sound.) Fig 1.
6. Press the foot pedal on the front of the cart and roll the cart from the machine. **E**
7. Attach battery cable from the batteries to receptacle on front of machine by pressing down on right hand side of locking bracket. (p/n 140190) **F**

Key	P/N	Description
1	VCT	CART, BATTERY REMOVAL
2	78243	TRAY, VGRB BATTERY LINER
3	78369	TRAY ASSEMBLY BATTERY
4	02143	(3) BATTERY, 12 VOLT
5	02267	CHARGER, 36 VOLT

\* NOTE: ONLY THE NEW "VCT" CART AND NEW TRAY ASSEMBLY WILL WORK WITH THE VOYAGER 2. PREVIOUS CARTS AND TRAYS, IN ANY COMBINATION, WILL NOT WORK.

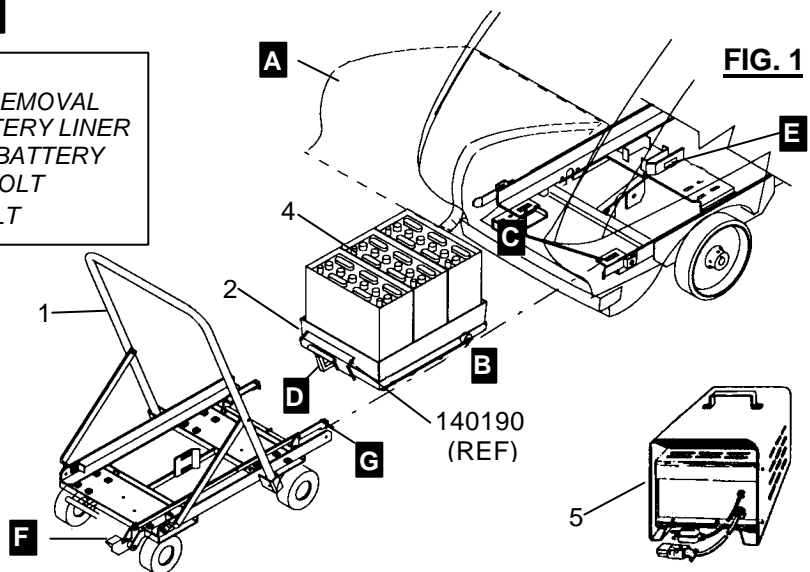

#### REMOVAL OF BATTERIES

BEFORE REMOVING BATTERY TRAY PLEASE FOLLOW THE INSTRUCTION SHEET 98439.

If you did not receive this sheet please contact Windsor Industries for this instruction sheet.



### CAUTION:

FOLLOW PROCEDURES CAREFULLY, BE SURE TO KEEPS HANDS AND FEET

1. Make sure the battery door is open. **A**
2. Disconnect battery cable from receptacle on front of machine.
3. Roll the cart up to the front of the machine aligning the front of the two frames.
4. Push the cart until the latches lock into the tabs located on the front of the machine. (The tabs cannot be seen when batteries are installed.) **B**
5. The latches are engaged when a "Snapping" sound is heard. Pull the handle on the tray. **D** (This releases the locking mechanism on the machine frame.) (Fig 1 & 2) Continue to pull handle until the battery pack rolls and locks onto cart. (The locking mechanism is engaged when a "Snapping" sound is heard.) **G**
6. Press the foot pedal located on the cart and roll the batteries and cart away from the machine. **F**

# BATTERY INFORMATION

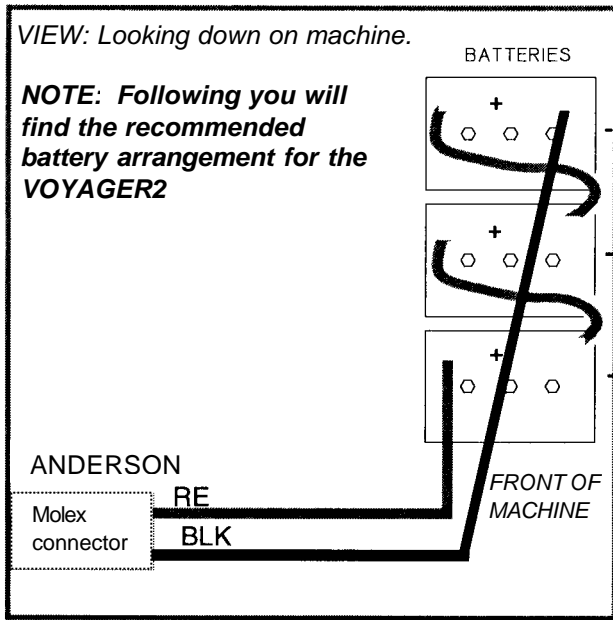

## BATTERY MAINTENANCE

1. When cleaning batteries use a solution of baking soda and water. (Do not allow cleaning fluid to enter inside battery cells.)
2. Keep a proper electrolyte level in the battery cells.
3. Wipe down the battery tops at least once a week. If a cell should accidentally overflow, clean it immediately.
4. Test the battery connection with a hydrometer at least once a week.
5. Ensure that all connections are tight and that all corrosion is removed.
6. Every 4 to 6 months remove batteries from the machine and clean the battery compartment.
7. Follow the Safety Procedures.

## ACCESSORIES

02143	Battery, 12V DC, 185 Amp Hour
00267	Charger, automatic 36V (20 amp) 115V
02264	Charger, automatic 36V (20 amp) 230V

### INTERNATIONAL

VCT	Battery cart system for service
78243	Battery tray liner
VXK	Battery Exchange Kit

## ACCESSORY TOOLS:

DHTK	Deluxe Hand Tool Kit
DDH	Double Dry Hand Tool
HFT	14" Flip Tool
89227	Standard Wand
89226	Deluxe Professional Wand
39128	12" Hose set

## BATTERY CHANGING PROCEDURE:

Charge the batteries once battery level indicator is near the level "0". **Do not let the batteries completely drain before changing.** Avoid charging the batteries before the amber light comes on.

**WARNING:** OPEN FLAMES, OR SPARKS NEAR BATTERIES AT ANY TIME.

**WARNING:** WEAR PROTECTIVE CLOTHING WHEN WORKING WITH BATTERIES.

**WARNING:** CHARGE IN A WELL VENTILATED AREA WITH BATTERY DOOR OPEN.

1. Use a 36 volt, 20 amp maximum output, D.C. charger which turns itself off when the batteries are fully charged. The charger must have a connector that matches the machine's battery connection.
2. Read the instructions and warnings provided by the battery charger manufacturer.
3. Set the charger in a well ventilated area on a level surface. Make sure cords will easily reach outlets on both machine and wall.
4. **Connect the charger to D.C. outlet on the machine first.**
5. Connect the A.C. power cord to properly grounded wall socket. **NEVER MAKE THE A.C. CONNECTION FIRST, HAZARDOUS SPARKS MAY RESULT.**
6. After the batteries are completely charged, disconnect the charger from the A.C. wall socket.
7. Once the charger is disconnected from the A.C. wall socket it is safe to disconnect the charger from the machine.
8. When batteries are fully charged, check the electrolyte level by removing the caps on top of batteries. If necessary, fill the cells with distilled water as shown in the diagram to the right. Be careful not to overfill the cells.

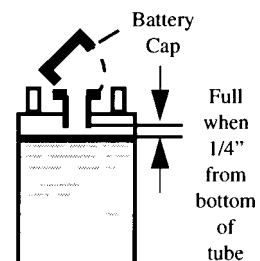

## OPERATION CONTROLS

1. **Brush Height Adjustment.** Raises and adjusts the height if the brush.
2. **Vac Shoe Lift Lever.** Lifts the vac shoe up or down and switches vac motor off and on.
3. **Battery Charge Meter.** Indicates the level of charge that the batteries are holding.
4. **Main Power Switch.** Turns ON and OFF the machine.
5. **Drive Handle Control Connection.** This is where Drive Control Connection Assembly is attached to rear panel.
6. **Drive Motor Circuit Breaker. 16 amp** Protects the drive motor mechanism.
7. **Vac Motor Circuit Breaker. 35 amp** Protects the vacuum motors.
8. **Brush Motor Circuit Breaker. 15 amp** Protects the brush motor.
9. **Accessory Tool Hookup.** Used for various auxiliary cleaning tools.
10. **Spray Position Switch.** Controls the spray adjustment between manifold and accessory tools.
11. **Hour Meter.** Records the use time.
12. **Pump Switch.** Turns ON and OFF the pump

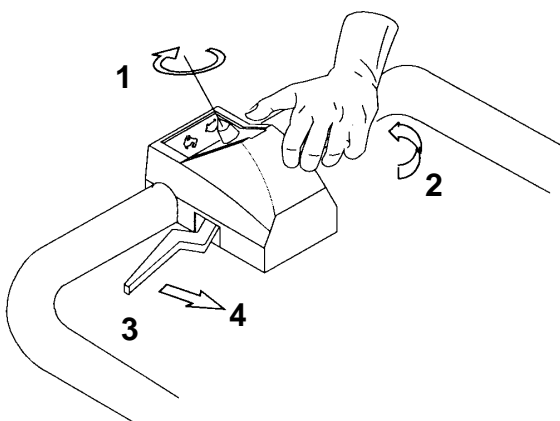
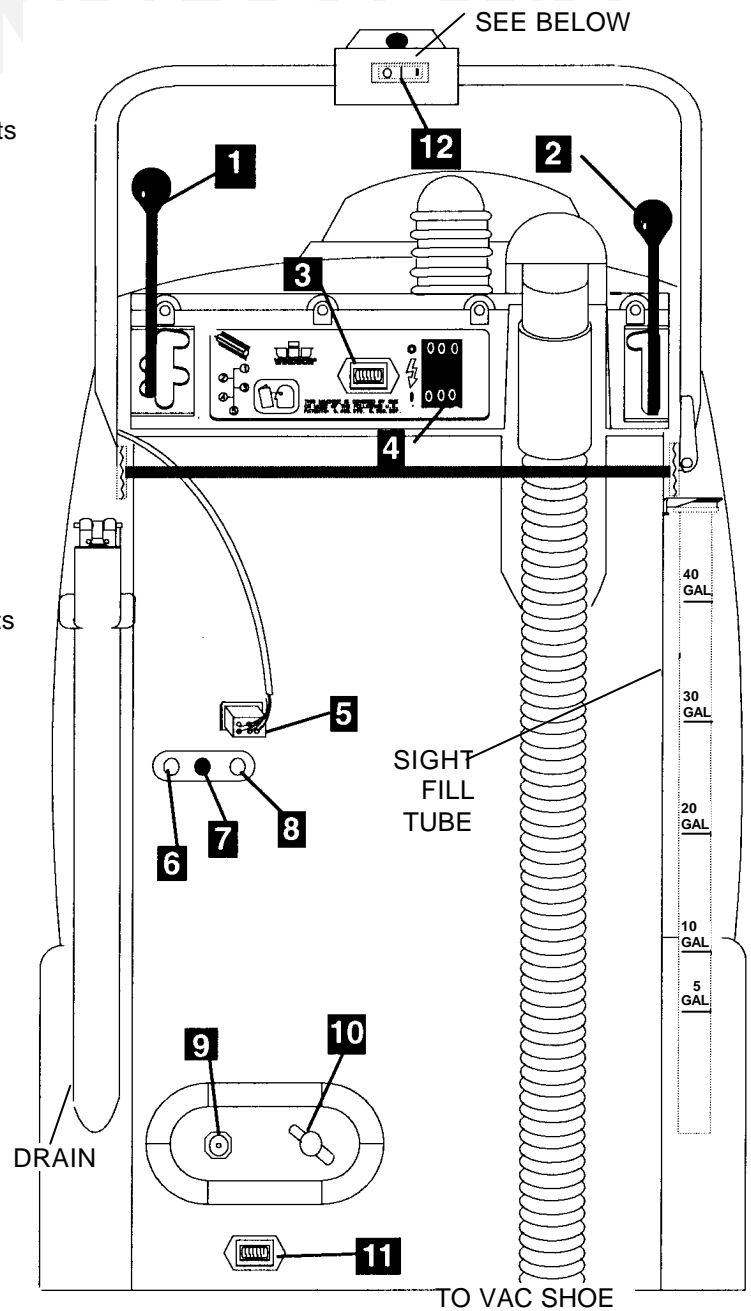

### VOYAGER DRIVE CONTROLS

1. The speed the machine will travel is regulated by the knob located on the controls which are found on the main handle. Turn the knob to the right to increase the speed of the machine.
2. Squeezing one or both of the control levers will propel the machine forward at the selected speed.
3. Releasing both control levers will stop the machine.
4. Pressing forward on the levers moves the machine backwards at the selected speed.

## OPERATIONS



Fill the solution tank to the desired level according to the marked gauge on the clear hose on the right side of the tank.  
**DO NOT FILL PAST THE INLET LIP.**

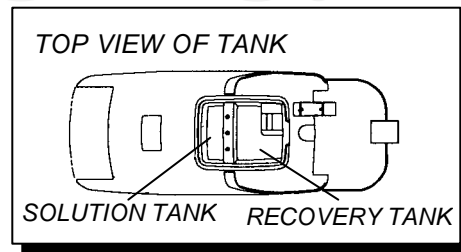

### **CAUTION:**

**IF A BUCKET IS USED TO FILL THE TANK, BE SURE IT IS CLEAN. DO NOT OVERFILL TO AVOID POSSIBLE DISTORTION OF THE FLEXSOL® DIAPHRAGM OR SOLUTION TANK. DO NOT USE WATER TEMPERATURE THAT EXCEEDS 140°F (60°C). LIQUID DETERGENTS ARE PREFERRED, however if a powered detergent is used, be sure it is fully dissolved. NOTE: If suitable powered detergent is used, premix with hot water before filling the solution tank.**

### **WARNING:**

**DO NOT PUT DEFOAMER, SOLVENTS, SPOTTER OR PRESpray CHEMICALS IN THE SOLUTION TANK.**

The internal parts of the pump used in the extractor are suitable for use with most carpet cleaning chemicals. However, it is susceptible to chemical attack from cleaning substances, such as hydrocarbon solvents and chlorinate bleaches. These noncombustible materials are not of the type normally used for carpet cleaning.

#### **CHEMICALS:**

##### **SUITABLE CHEMICALS**

Alkalis                Soaps  
Detergents          Vinegar  
Hydroxides         D-Limonene @  
                             @ When properly diluted  
                             \* Registered Trademark

##### **NONCOMPATIBLE CHEMICALS**

Aldehydes            Chlorinated Hydrocarbons  
Aromatic Hydrocarbons    Lysol\*  
SP Butyls            Methyl Ethel Ketone (MEK)  
Carbon Tetrachloride      Perchlorethylene (perc)  
Chlorox\*              Phenolics  
Chlorinated Bleaches      Trichlorethylene

#### **FILLING THE VOYAGER**

1. Remove the Dome.
2. Use a **CLEAN** bucket or hose to fill solution tank with hot water not to exceed 140°F (60°C). Do not fill above lower tank lip. Add non-foaming carpet extraction chemical at recommended proportion. **NOTE: If suitable powdered detergent is used, premix with hot water filling the solution tank.**

#### **BEGIN CLEANING**

1. Adjust handle to comfortable position at waist level.
2. Turn solution valve, located on bottom of rear position.
3. Turn **MAIN POWER** switch **ON**.
4. Adjust **SPEED CONTROL KNOB** on handle to set desired maximum speed.
5. Turn **SOLUTION** switch **ON**.
6. Lower **BRUSH** using left hand lever until contact with carpet is reached. Brush motor will start automatically.  
**NOTE: Incorrect brush height may trip circuit breaker or cause belt slippage. To correct, raise brush and reset circuit breaker located on rear panel.**
7. Lower **VACUUM** using right hand lever. Vacuum motor will start automatically.
8. Depress **SPEED LEVER** to propel machine. Speed is controlled by lever up to the maximum set on **CONTROL KNOB**.  
**NOTE: For protection, the Voyager will not operate in reverse when brush is on.**





#### **CLEANING PROCEDURE**

1. Operate machine in parallel passes, overlapping 2 inches on each pass. Turn **SOLUTION** switch **OFF** on turns. Propel machine gently into turns. Abnormal turns may activate vacuum motor shut-off. Clean perimeter last.
2. Run machine more slowly over spots or extremely soiled areas.
3. Use right side of **VOYAGER** when cleaning against walls.
4. Turn **SOLUTION** switch **OFF** 3 feet before completing a cleaning pass to ensure all solution is vacuumed from carpet.  
**CAUTION: WHILE OPERATING MACHINE, CHECK FOR EXCESSIVE FOAM BUILD-UP IN RECOVERY TANK. IF EXCESSIVE FOAM IS PRESENT, ADD DEFOAMER SOLUTION TO RECOVERY TANK OR EMPTY RECOVERED SOLUTION.**
5. To speed dry, use a **WINDBLOWER** fan and ensure building ventilation system is **ON**.
6. Empty recovery tank when full by releasing dump hose and removing stopper. **NOTE: Vacuum motor will stop if recovery tank is full.**
7. Turn **MAIN POWER** switch **OFF** after use.  
**NOTE: Check the Circuit Breaker if the Voyager does not start.**



## ACCESSORY TOOLS & MAINTENANCE

### ACCESSORY

1. Attach the auxiliary solution hose to the output nipple A.
2. Disconnect hose at vac shoe using and connect vac hose using coupler (22071) that is included with Voyager machine.
3. Turn the solution control valve B to 
4. Press the Pump switch "ON".
5. Lower the vac lever to the "ON" position to start the vac motor.
6. Make sure the solution control valve is returned to the 
7. position before using the Voyager for self-contained carpet cleaning.

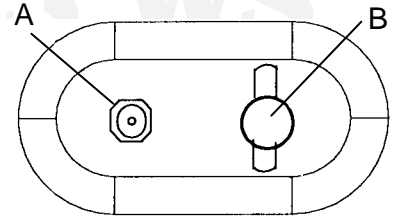

### CLEANUP AND STORAGE

Empty the Recovery Tank directly into the floor drain. After each use, rinse tank (including the float-off) with fresh water. Periodically inspect the recovery tank and decontaminate if necessary, using a Hospital Guide Virucide or a 1-10 bleach to water solution. This will dissipate the exposure to blood born or infectious contamination. Waste water should be disposed of properly. Clean the inside of the recovery dome also.

*Empty the Solution Tank by detaching the sight hose and empty directly into the floor drain.*

*Flush the Solution System with 1 gallon of CLEAN water.*



**CAUTION:**

**Never allow recovered solution to remain in tank when not in use; nor allow unused solution to remain in the solution tank when in storage. Inspect and clean the filter located at the pump port. Remove and rinse with hot water.**

### PERIODIC MAINTENANCE

#### EVERY TWO WEEKS:

Clean the solution system by diluting 2 gallons of clean water with a quart of white vinegar (acetic acid) in the solution tank. Run the solution through the system to remove chemical buildups which could eventually cause it to plug up.

#### EVERY 500 HOURS:

Oil the front drive wheel bearings by removing the phillips screw "A" and by loosening the (2) set screws "B" located on the outside of wheel assembly. Slide the wheel off the axle and apply 6 drops of 10W oil to bearings. Be careful not to lose the key in shaft.

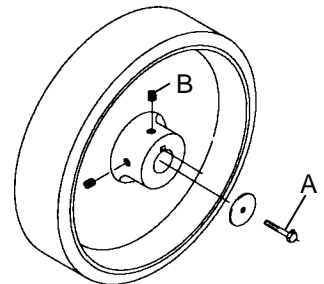

### INSPECTION



**WARNING:**

**Remove the batteries (using the battery cart if available) before making any adjustments or repairs to the Voyager2.**

To expose working parts for inspection, lay dome back on handle, grasp tank at solution opening and tilt the tank forward until "NOSE" of tank rests on floor.

WWW.MANUALS.WS

## ACCESSORY TOOLS & MAINTENANCE

### **WARNING:**

ONLY QUALIFIED MAINTENANCE PERSONNEL ARE TO PERFORM THE REPAIRS.

Remove the batteries (using the "Battery Cart" if available) before making any adjustments or repairs to the Voyager2.

### **CAUTION:**

WHEN REPLACING THE ELECTRICAL PARTS REFER TO THE MACHINE WIRING DIAGRAM FOR PROPER CONNECTIONS.

### REAR PANEL REMOVAL

Remove the vac shoe hose from tank, lay dome back, remove handle and open the front battery door. Open the tank slowly to upright position. Remove (2) top and (2) bottom screws on rear panel.

### TANK REPAIR

The tanks are made of Polyethylene. Small holes or crack can be repaired by using heat. Apply low heat from a torch to the damaged area until the material is softened. Use a screw driver blade or other flat head metal tool to seal damaged area.

### VACUUM MOTOR REMOVAL

1. Turn main power off.
2. Remove the rear Control Panel and open tank to upright position.
3. Disconnect the hose from the vac motor intake.
4. Disconnect the vac motor leads from the terminal couplers & ground post.
5. Remove the (3) screws holding the vac motor to the rear frame and remove the vac motor.
6. To inspect the motor brushes, remove the brush holder assembly. Brushes should be replaced when worn to 3/8 inch or about 750 operating hours. After second brush replacement, armature commutator should be checked for pitting and concentricity. Vacuum motors can be repaired, but such repairs should be made by a qualified motor repair shop.
7. Clean out dust using a vacuum to prevent injury to eyes or contamination of the bearings.

### Vacuum Motor Carbon Brushes Replacement (Ametek)

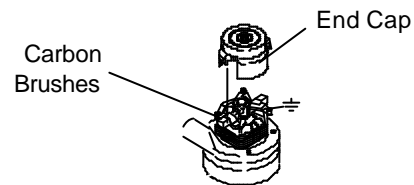

If armature commutator is grooved, extremely pitted or not concentric, the motor will need to be replaced or sent to a qualified service center.

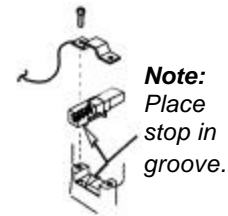

#### Important:

These brushes wear quicker as the length shortens due to increased heat. Spring inside brush housing will damage motor if brushes are allowed to wear away completely.

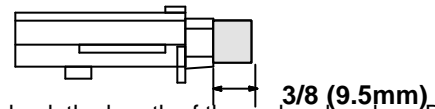

Periodically check the length of the carbon brushes. Replace both carbon brushes when either is less than 3/8" (9.5mm) long.

### Vacuum Motor Carbon Brushes Replacement (Windsor)

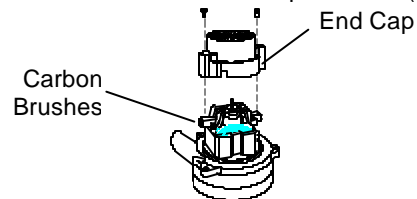

If armature commutator is grooved, extremely pitted or not concentric, the motor will need to be replaced or sent to a qualified service center.

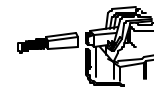

#### Important:

These brushes wear quicker as the length shortens due to increased heat. Spring inside brush housing will damage motor if brushes are allowed to wear away completely.

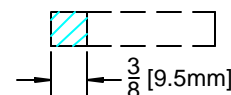

Periodically check the length of the carbon brushes. Replace both carbon brushes when either is less than 3/8" (9.5mm) long.

**SOLUTION PUMP REMOVAL**

1. Turn main power off.
  2. Disconnect the two pump wire leads.
  3. Remove (4) screws holding the pump to the main frame.
  4. Lift the pump out to access solution inlet and disconnect from the pump head.
- Refer to the pump drawing page 16 for replacement parts.**

**BELT / BRUSH ASSEMBLY REMOVAL**

1. Turn main power off.
2. Use brush height adjustment lever to lower brush to its lowest position.
3. Remove the belt guard.
4. Now remove the brush pulley guard.
5. Loosen tension in belt by moving idler pulley clockwise.  
Simultaneously remove belt from motor pulley, while holding idler pulley. Once belt has been removed from motor pulley, slowly let idler pulley rotate counterclockwise. Do not loosen spring.
6. Remove the screw from each end of the brush shaft.
7. Swing the brush assembly out of the housing to remove the belt.

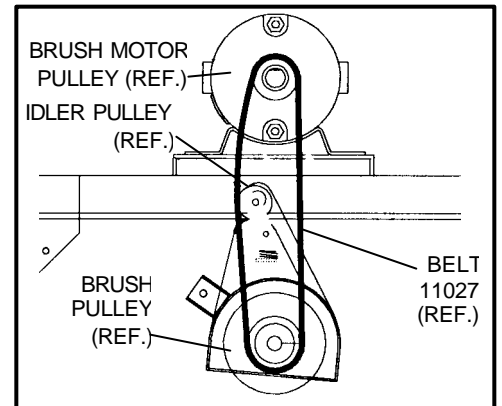

# MAINTENANCE

## MANIFOLD / SPRAY JETS

To prevent clogged jets due to alkaline build-up, the spray system should be flushed with 1 gallon of clean hot water at the end of each work day. The **VOYAGER2** is equipped with “quick change” jets that can be easily removed for cleaning. To remove – push jet in and rotate. Do not use pins or wire to remove obstruction as this will damage jet and alter spray pattern.

- 1 66095 PLUG, 1/8 NPT HEX BRASS
- 2 44052 JETBODY, BRASS W/SEAL
- 3 54138 MANIFOLD ASM, 3 JET
- 4 40033 HOSEBARB, 1/4 MPT X 3/8 90D
- 5 66052 PIN, 1/8 X 1.0 ROLL
- 6 73576 SPRING, 2" X .600 OD
- 7 44060 JET, 8002 MINI-QUICK REPLACEMENT
- 8 44051 JET SEAL, MINI QUICK
- 9 54162 MANIFOLD A

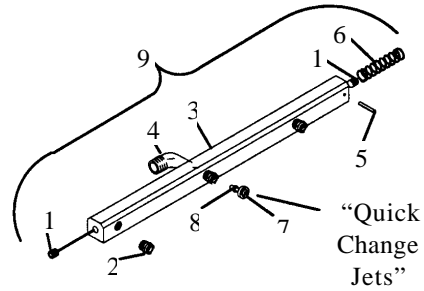

## VAC SHOE TRACKING

To adjust shoe tracking, move eyebolts in or out to increase or decrease spring force, respectively, until desired tracking is reached.

## VAC SHOE DOWNPRESSURE

*NOTE: DOWNPRESSURE IS FACTORY SET AND SHOULD NOT REQUIRE ADJUSTMENT.*

If adjustment of downpressure is required, turn black knob on top of vac shoe clockwise to increase downpressure and counterclockwise to decrease downpressure.

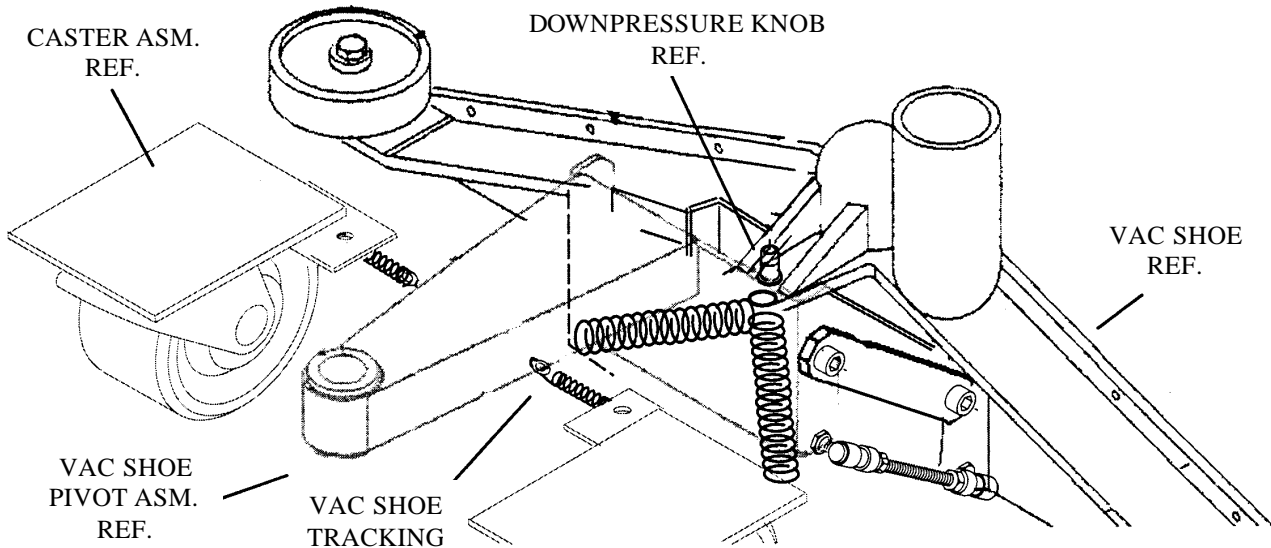

## VAC SHOE ANGLE

*NOTE: THE ANGLE OF THE VAC SHOE IS FACTORY SET AND SHOULD NOT REQUIRE ADJUSTMENT.*

Periodically inspect the vac shoe angle by resting it on a hard, flat surface. Use a square to verify a 90° angle between the floor and vertical surface of the vac shoe.

If adjustment is required, remove one socket on each lower arm (from the vac shoe or bracket) and turn clockwise or counterclockwise to change the angle to the recommended 90°. Attach the socket on each arm to its respective location and recheck the angle using the square. Repeat if necessary.

## SIDE VIEW OF VAC SHOE

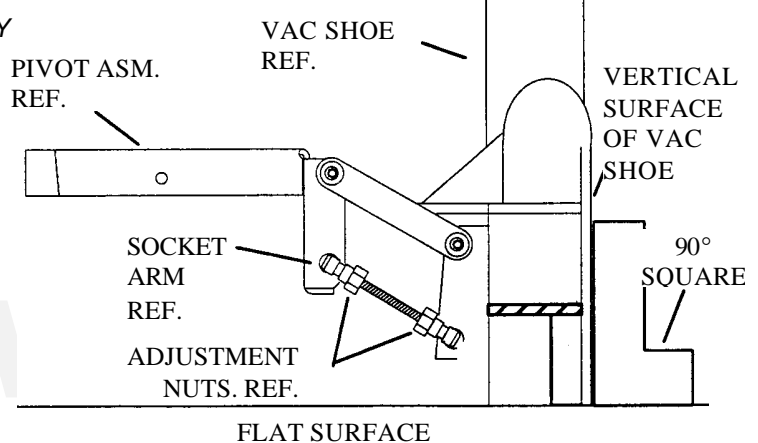

**SERVICE SCHEDULE**

<b>MAINTENANCE</b>	<b>DAILY</b>	<b>WEEKLY</b>	<b>QUARTERLY</b>
Check recovery dome and gasket for damage and cleanliness	*		
Check batteries after charging, add water if necessary	*		
Check brush – should be clean with no lint or strings attached	*		
Inspect vac shoe for blockage; remove fibers with coat hanger, etc.	*		
Check hoses for wear, blockages, or damage	*		
Check handles, switches, and knobs for damage	*		
Check vac motor intake filter and clean	*		
Run one gallon of water through system	*		
Clean out recovery tank and check float valve to make sure it moves freely	*		
Clean out solution tank and remove and clean vacuum intake screen	*		
Clean outside of all tanks and check for damage	*		
Run vac motor for at least one minute to allow motor to dry	*		
Store with dome off tank to allow the tank to dry	*		
Check batteries for corrosion, cracks, and evidence of overheating		*	
Check all bearings for noise		*	
Check all gaskets for wear and leakage		*	
Check vacuum intake screen for damage; replace if necessary		*	
Check pump pressure; observe spray pattern and check with gauge if necessary		*	
Check and clean solution screen		*	
Check belts for wear and replace as necessary		*	
Check brush for wear; ensure bristles are not damaged		*	
Check cables for fraying		*	
Check the spray bar (manifold) for damage; replace if broken or bent		*	
Check condition of vac shoe and frame for damage		*	
Check overall performance of machine		*	
Check vac motor carbon brushes			*
Check chains for wear and lube as necessary			*

# PROPEL HANDLE ASSEMBLY

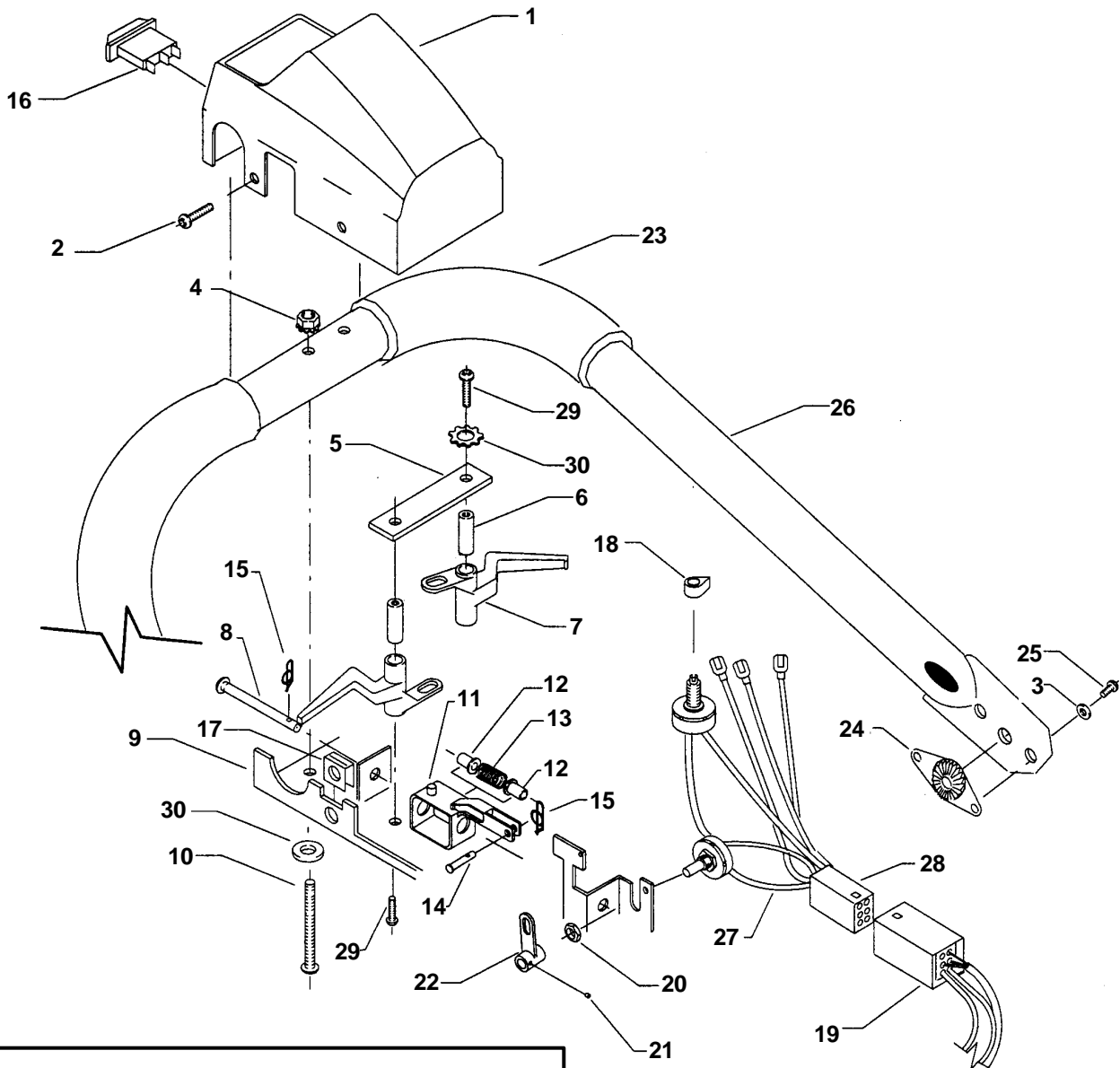

VIEW: CONNECTION DETAIL

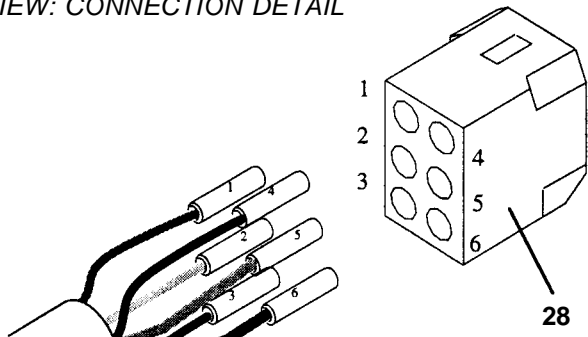

Color	AWG	Position
Blue	20	1
Black	20	2
Brown	20	3
Orange	20	4
White	20	5
Red	20	6

## PROPEL HANDLE ASSEMBLY

REF	PART NO.	QTY	DESCRIPTION	SERIAL NO. FROM	NOTES:
1	27551	1	COVER, PROPEL HANDLE		
2	70406	4	SCREW, 10B X 3/8 PHSM BLK		
3	87018	4	WASHER, #10 X 9/16 OD		
4	57236	2	NUT, 10-32 HEX NYLOCK BLK		
5	71116	1	SUPPORT, LEVER PIVOT		
6	67271	2	ROD, HANDLE LEVER PILOT		
7	51186	2	LEVER, PROPEL CTRL HANDLE		
8	66184	1	PIN, CLEVIS 1/4 X 2.438		
9	62705	1	PLATE ASSEMBLY, PROP. CTRL.		
10	70209	2	SCR, 10-32 X 1.75 PHMS		
11	36136	1	GUIDE, LEVER CENTERING		
12	14866	2	BUSHING, PROPEL CONTROL		
13	73236	1	SPRING, COMP. .36D X .12L X .04W		
14	66191	1	PIN, CLEVIS 3/16 X 1/2		
15	80604	2	RING, RUE COTTER 1/4"		
16	72087	1	SWITCH, 36VDC SPST ILLUM.		
17	57028	4	NUT, 10-24 TINNEMAN		
18	48043	1	KNOB, PT26/32 SPEED CONTROL		
19	880092	1	WIRE ASM, HANDLE TO POWER		
20	57024	1	NUT, 3/8-27 PANEL		
21	70084	1	SET SCREW, 8-32 X 3/16 KCP		
22	66183	1	PIVOT, POTENTIOMETER		
23	36123	2	GRIP, CLP HANDLE, X 9.5"		
24	51184	2	LOCK, HANDLE ADJUSTMENT		
25	70228	4	SCREW, 10-32 X 1/4 PHSM		
26	38183	1	HANDLE, VGRB MAIN		
27	88748	1	WIRE ASM., VGR. HANDLE		
28	27554	1	CONN., MOLEX 6 PIN RECEPT. (M)		
29	70088	4	SCR, 10-32 X 1/2 PPHMS		
30	87016	6	WASHER, #10 LOCK EXT. STAR		

### ***Installation and adjustment of potentiometers for drive control speed***

#### **STEP PROCEDURE**

- 1 Turn the speed potentiometer fully clockwise. (Max. speed)
- 2 Measure the potentiometer resistance at connector (**#27**) BROWN and BLACK wires. The resistance should measure 2200-2800 ohms in neutral, 4800-5000 ohms in forward, and 0-200 ohms in reverse. If adjustment is necessary loosen set screw (**#21**) and adjust potentiometer T for 2500 ohms in Neutral. Tighten set screw (**#21**).
- 3 Turn the main switch power on.
- 4 If the machine moves when control lever is in neutral adjust the direction potentiometer until movement stops.

# DRIVE & BRUSH ASSEMBLY

WWW.MANUALS.WS

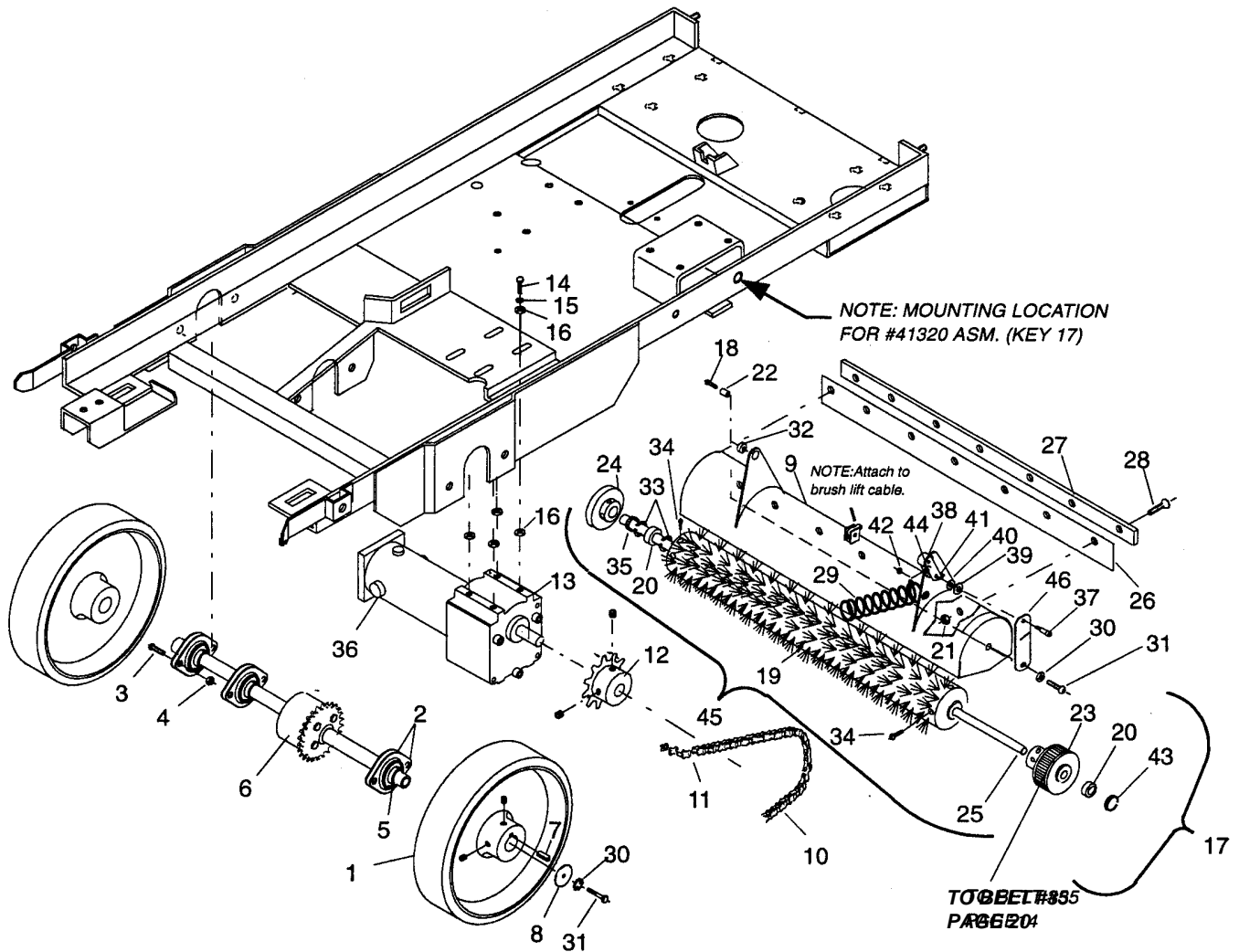

WWW.MANUALS.WS



## DRIVE BRUSH ASSEMBLY

REF	PART NO.	QTY	DESCRIPTION	SERIAL NO. FROM	NOTES:
1	89078	2	WHEEL, 10" X 2 -1/2" BORE		
2	81003	3	FLANGETTE, 1" BEARING PAIR		
3	70305	4	SCREW, 5/16-18 X 3/4 HHCS		
4	57113	4	NUT, 5/16-18 NYLOCK PLTD		
5	81002	3	BEARING, 1" BORE		
6	29156	1	DIFFERENTIAL		
7	48052	2	KEY, 1/4 X 1/4 X 2-1/2		
8	87008	2	WASHER, 1/4 ID X 1-1/4 OD		
9	41288	1	HOUSING, BRUSH		
10	27569	1	CHAIN, #40 1/2 PITCH X 39		
11	27343	1	CHAIN, MASTER LINK, #40 1/2		
12	73567	1	SPROCKET, #40 11 TOOTH		
13	53610	1	MOTOR ASM, VGR 36V		
14	70432	4	SCREW, 5/16-24 HHCS SS		
15	87166	4	WASHER, 5/16 EXT. LOCK		
16	87090	8	WASHER, 1/4 ID X 3/4 OD PLTD		
17	41320	1	HOUSING ASSEMBLY		
18	70104	2	SCREW, 3/8-16 X 3/4 BHMS		
19	12022	1	BRUSH, VGRB		
20	09019	2	BEARING, BRUSH		
21	57104	7	NUT, 10-32		
22	73606	2	SPACER, .50 OD X .38 ID X .260 L		
23	64103	1	PULLEY, BRUSH VGRB		
24	27607	1	COVER, BRUSH CORE		
25	03091	1	AXLE, BRUSH DRIVE		
26	36175	1	GUARD, VOYAGER SPLASH		
27	67106	1	RETAINER, SPLASH GUARD		
28	70088	7	SCREW, 10-32 X 1/2 PPHMS		
29	73578	1	SPRING, 4.00 .75 OD EXT		
30	87025	4	WASHER, 1/4 LOCK EXT STAR		
31	70011	4	SCREW, 1/4-20 X 5/8 PPHMS		
32	09025	2	BEARING, 1/2 ID NYLINER		
33	67094	2	RING, 1/2 EXT. SNAP		
34	70088	8	SCREW, 10-32 X 1/2 PPHMS SS		
35	67098	1	RING, TOLERANCE		
36	140063	1	BRUSH SET, 36V VGR DRIVE		
37	70267	1	SHOULDER BOLT, 5/16 OD X 1.25		
38	64101	1	PULLEY ASM., VGR		
39	87029	1	WASHER, 5/16 FLAT SAE		
40	87030	1	WASHER, 3/8 ID X 3/4 OD NYL		
41	73307	1	SPRING, COMP. .88D X 1.4L X .1W		
42	57047	1	NUT, 1/4-20 NYLOCK PLTD		
43	67093	1	RING, 1 1/8 INT. SNAP		
44	87074	1	WASHER, WAVE		
45	12508	1	BRUSH ASM, VGR		
46	62820	1	PLATE, VGR PULLEY		

**Replacement of Drive Motor brushes (p/n 40063):**

1. Using a standard head screwdriver, remove cap covering brush inlet.
2. Using a pair of needle nosed pliers, gently remove brush (including spring) and replace with new part.

# PUMP, VAC, MANIFOLD & BRUSH MOTOR ASSEMBLIES

## Replacement of Motor brushes (#28)

**CAUTION:** TURN POWER OFF.

1. Using a standard head screw driver, remove cap covering brush inlet.
2. Using a pair of needle nose pliers, gently remove brush (including spring) and replace with new part.

REPLACEMENT PART FOR THIS ITEM 19  
ON PAGE 19

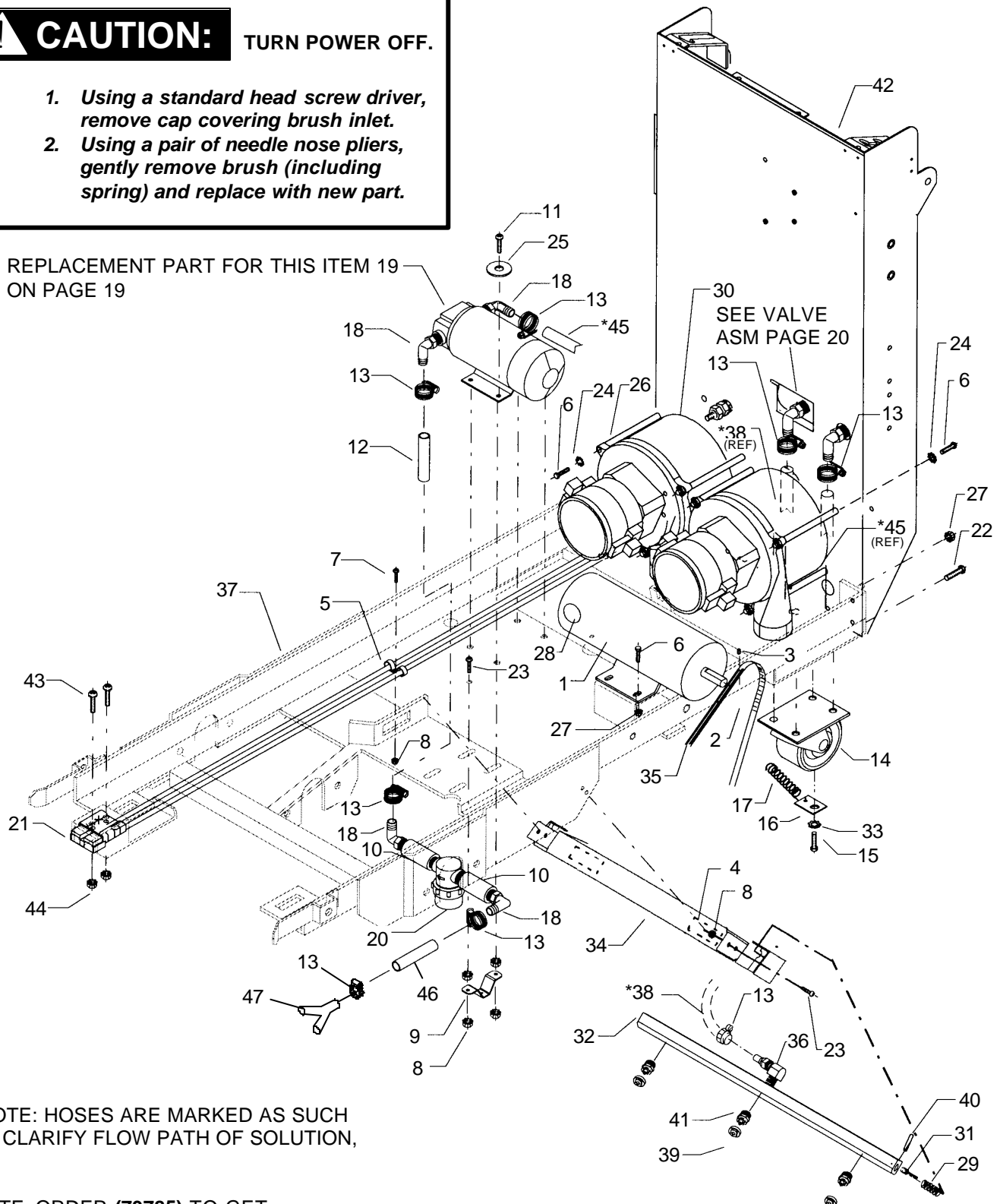

\*NOTE: HOSES ARE MARKED AS SUCH TO CLARIFY FLOW PATH OF SOLUTION,

NOTE: ORDER (73785) TO GET REPLACEMENT SCREEN FOR STRAINER (73573) ITEM 20.

# PUMP, VAC, MANIFOLD & BRUSH ASSEMBLIES

REF	PART NO.	QTY	DESCRIPTION	SERIAL NO. FROM	NOTES:
1	53622	1	MOTOR ASM, 36VDC VGR2		
2	64022	1	PULLEY, POLY-V BELT		
3	70074	2	SET SCREW, 10-32 X 1/4 KCP		
4	99873	2	TAPE, 5/8 X 1/4 X 3" PORON		
5	20005	2	CLAMP, 5/16 NYLON		
6	70011	16	SCREW, 1/4-20 X 5/8 HHCS		
7	70088	1	SCREW, 10-32 X 1/2 PPHMS		
8	57104	12	NUT, 10-32 W/ STAR WASHER		
9	14454	1	BRACKET, VALVE		
10	22003	2	COUPLER, 3/8 FPT X FPT		
11	70253	4	SCREW, 10-32 X 1.25 PHMS		
12	39486	1	HOSE, 3/8 NYLOBRAID X 2"		
13	20042	8	CLAMP, 3/8 HOSE (D-SLOT)		
14	040-03	2	CASTER SWIVEL 4" 250# CPCTY		
15	70305	8	SCREW, 5/16-18 X 3/4 HHCS		
16	62394	2	PLATE, SPRING HOOK		
17	73240	2	SPRING, 1/2 X 2.25L EXTENSION		
18	40034	4	HOSEBARB, 3/8 MPT X 3/8 90D		
19	65166	1	PUMP ASM, 36VDC VGR2		
20	73573	1	STRAINER, 3/8 NPT 80 MESH		
21	880101	1	WIRE ASM, VGR MAIN POWER		
22	70329	4	SCREW, 1/4-20 X 3/4 PHMS		
23	70066	5	SCREW, 10-32 X 3/4 PPHMS		
24	87025	12	WASHER, 1/4 LOCK EXT STAR		
25	87018	4	WASHER, #10 X 9/16 OD		
26	73566	6	SPACER, 1/2 OD X 3.0 W/ 1/4-20		
27	57047	4	NUT, 1/4-20 NYL SELF LOCK		
28	140066	1	BRUSH, 36V VGR BRUSH MTR		
29	73576	1	SPRING, 0.6 OD X 2.0L COMPR		
30	53782	2	VAC MOTOR ASM, 36VDC		
-	140658	1	BRUSH SET, VAC MTR 53204		SERVICE ONLY
-	140686	1	BRUSH SET, 24V/36V VAC WINDSOR		SERVICE ONLY
31	66095	2	PLUG, 1/8 MPT HEX BRASS		
32	54139	1	MANIFOLD ASM, VGR 3-JET		
33	87067	8	WASHER, 5/16 LOCK INT STR.		
34	14902	1	BRACKET, VGR MANIFOLD		
35	11027	1	BELT, BRUSH DRIVE ASSEMBLY		
36	40033	1	HOSEBARB, 1/4 MPT X 3/8 90D		
37	34270	1	FRAME, VGR2 MAIN		
38	39204	1	HOSE, 3/8 NYLOBRAID X 29"		
39	44060	3	JET, 8002 MINI-QUICK		
40	66052	1	PIN, 1/8 X 1" ROLL		
41	44052	3	JETBODY, MINI-QUICK W/ SEAL		
42	34308	1	FRAME, VGR2 REAR		
43	70261	2	SCREW, 6-32 X 1.0 PHMS PLTD.		
44	57116	2	NUT, 6-32 E/ STAR WASHER		
45	39365	1	HOSE ASM, 3/8 ID NYLOBR X 25		
46	39499	1	HOSE, 3/8 X 13		
47	12-800398	1	Y FITTING		

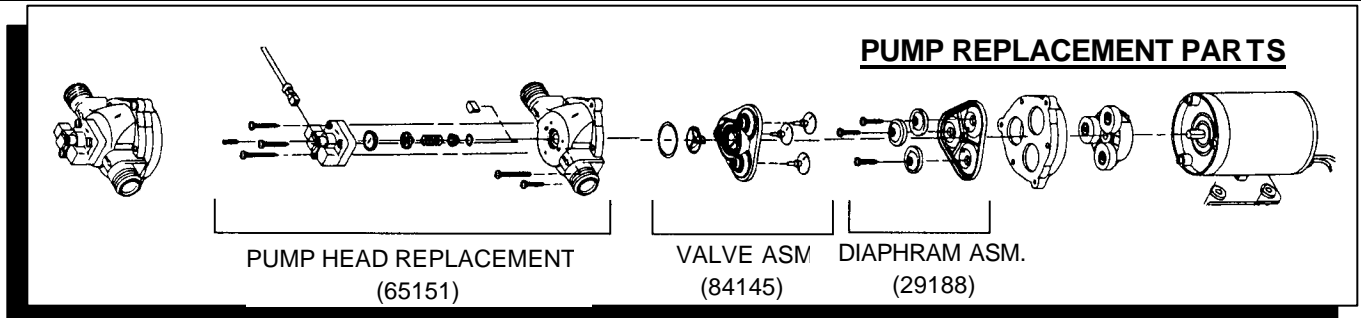

# REAR TOWER ELECTRICAL ASSEMBLIES

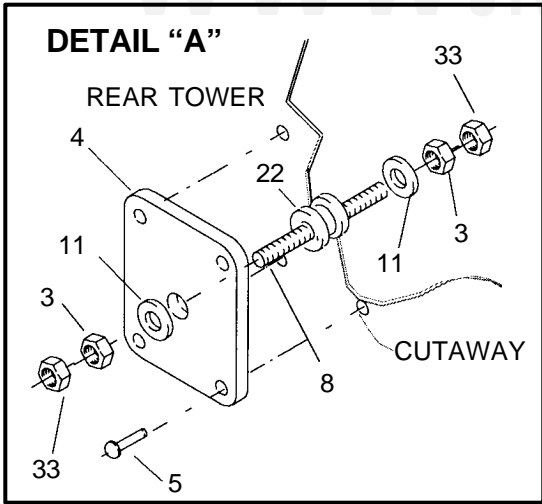

NOTE: SUPPLIED WITH RELAY

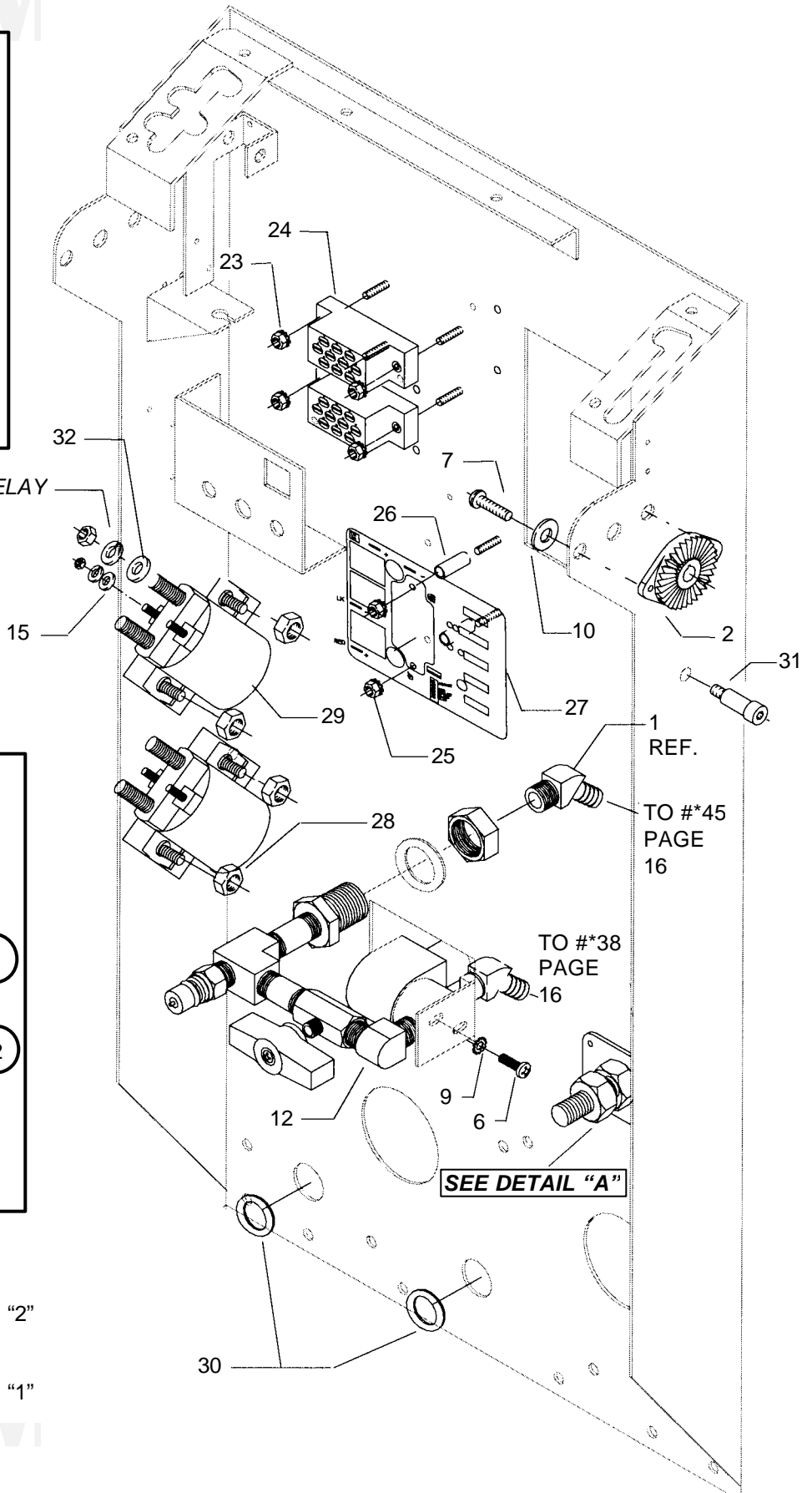
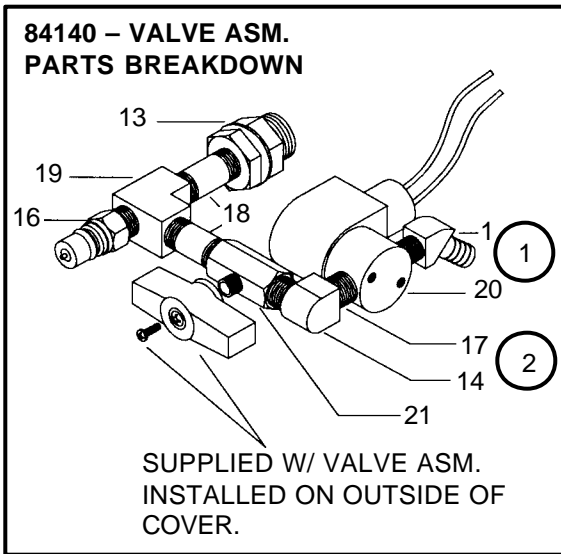

**NOTES:**

- ① LOCATE @ PORT MARKED "P" OR "2"
- ② LOCATE @ PORT MARKED "A" OR "1"

## REAR TOWER ELECTRICAL ASEMBLIES

REF	PART NO.	DESCRIPTION	SERIAL NO.	NOTES:
1	40038	HOSEBARB, 1/4 MPT X 3/8 H 45DEG.		
2	51184	LOCK, HANDLE ADJ.		
3	57125	NUT, 5/16-24 HEX JAM		
4	62561	PLATE, NEGATIVE POST		
5	67005	RIVET, 1/8 OD WHT AL		
6	70162	SCREW, 10-32 X 3/8 PHMS SS		
7	70228	SCREW, 10-32 X 1/4 PHMS SS		
8	70289	SCREW, STUD, 5/16-18 X 2.12 BRASS		
9	87016	WASHER, #10 LOCK EXT STAR		
10	87018	WASHER, #10 X 9/16 OD		
11	87092	WASHER, 5/16 X 3/4 BRASS		
12	84140	VALVE ASM, 36V		
13	22072	COUPLING, 1/4 ANCHOR		
14	31016	ELBOW, 1/4 NPT		
15	87095	WASHER, #10 FLAT PLTD.		
16	56012	NIPPLE, 1/4 FPT QD		
17	56014	NIPPLE, 1/4 CLOSE		
18	56048	NIPPLE, 1/4 X 1.75		
19	78308	TEE, 1/4 STREET		
20	84168	VALVE, 120V 110PSI SOLENOID		
21	84065	VALVE, 1/4 FPT BALL		
22	36019	GROMMET, 5/16 ID X 9/16 GRV.		
23	57116	NUT, 6-32 W/ STAR WASHER		
24	14020	TERMINAL BLOCK, 115V (3-4-3)		
25	57106	NUT, 8-32 W/ STAR WASHER		
26	73734	SPACER, .166ID X .313OD X .75L		
27	27672	CONTROLLER, 36VDC PROPEL MOTOR		
28	57047	NUT, 1/4-20 NYLOCK PLTD.		
29	67315	RELAY, 36VDC 100AMP HVY DUTY		
30	36020	GROMMET, 5/8 ID X 1.12 OD		
31	70488	SHOULDER BOLT, 5/16 OD X 3/4 L		
32	87029	WASHER, 5/16 FLAT SAE		
33	57113	NUT, 5/16-18 NYLOCK PLTD		

# HANDLE, MIRCOSWITCH AND CABLE ASSEMBLIES

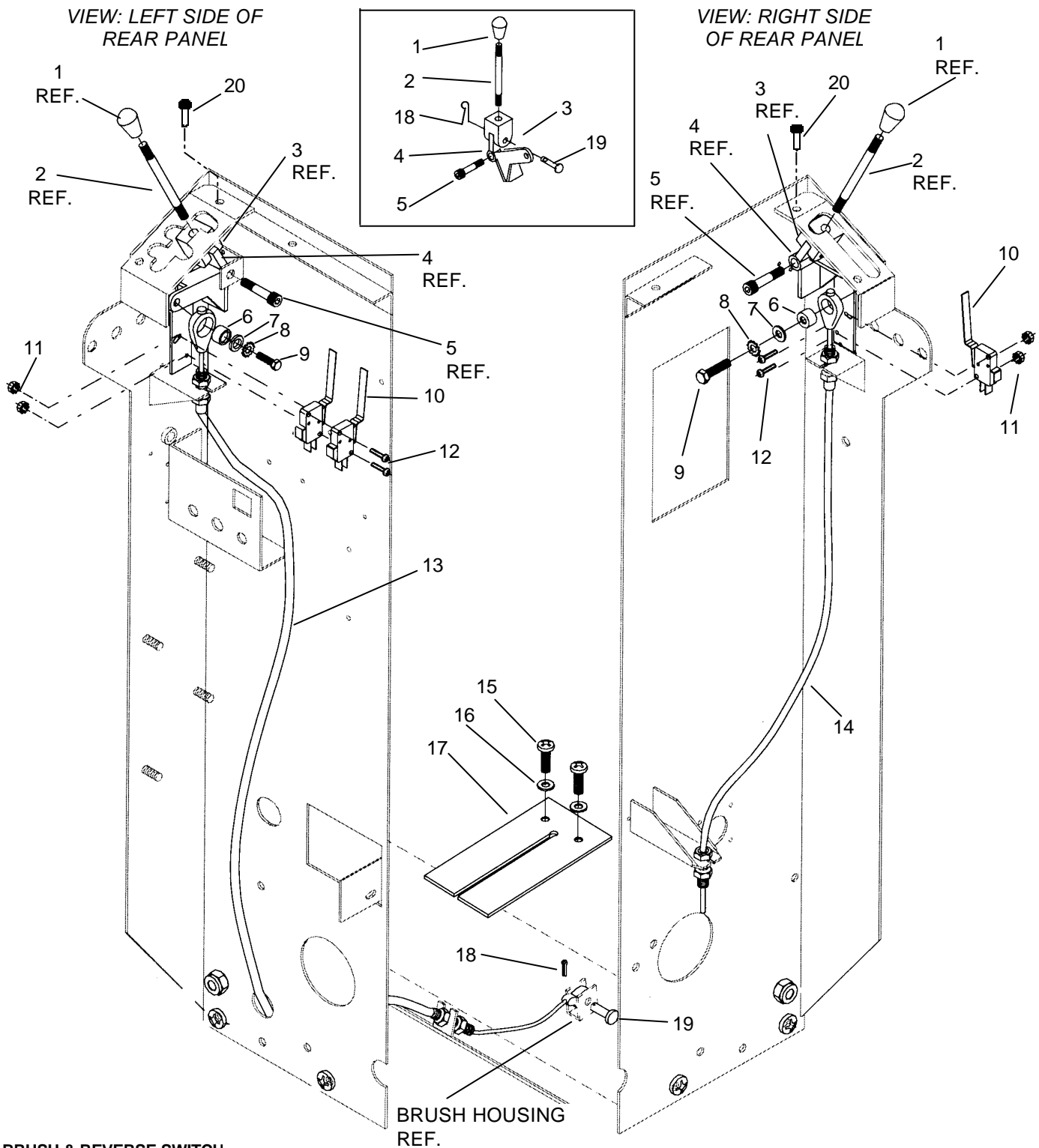

## BRUSH & REVERSE SWITCH

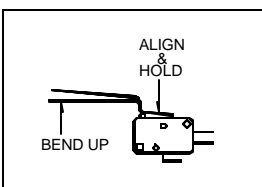

NOTE: FOR BRUSH AND REVERSE SWITCHES, ALIGN THE TWO SWITCHES AND CHECK TO SEE THAT THE ACTUATOR TABS ARE EVEN TO WITHIN 1/16 INCH. IF REQUIRED, BEND THE LOWER TAB UP TO MATCH THE HIGHER TAB. INSTALL THE SWITCHES WITH THE SCREWS LOOSE ENOUGH TO ALLOW THE TOP SCREW TO SLIDE IN THE MOUNTING SLOT. WITH THE LEVER IN THE TOP POSITION, SLIDE THE SWITCHES BACK UNTIL THEY BOTH CLICK, TIGHTEN THE SWITCHES IN THIS POSITION.

## HANDLE, MICROSWITCH & CABLE ASSEMBLIES

REF	PART NO.	QTY	DESCRIPTION	SERIAL NO.	NOTES:
1	48030	2	KNOB, PT17/20 BLACK		
2	38186	2	HANDLE, BRUSH/VAC CONTROL		
3	27559	2	CLEVIS, 3/8-16 UNC ROD END		
4	51170	2	LEVER ASM, HANDLE PIVOT		
5	70117	2	SHOULDER BOLT, 5/16 OD X 1.0 L		
6	73220	2	SPACER, EPB CABLE/CASE HARD		
7	87013	2	WASHER, 1/4 ID X 5/8 OD SS		
8	87025	2	WASHER, 1/4 LOCK EXT STAR SS		
9	70011	2	SCREW, 1/4-20 X 5/8 HHCS SS		
10	72082	3	SWITCH, SOL LEVER BENT		
11	57163	4	NUT, 4-40 W/ STAR WASHER		
12	70401	4	SCR, 4-40 X 1.25 PHMS		
13	27486	1	CABLE, BRUSH LIFT		
14	27488	1	CABLE, VAC SHOE LIFT		
15	70187	2	SCREW, 10-24 X 1/2 PHTC -F-		
16	87018	2	WASHER, #10 X 9/16 OD		
17	36179	1	GUARD, SPLASH		
18	66073	3	PIN, COTTER 1/16" X 3/4" L PLTD		
19	66116	3	PIN, CLEVIS 1/4" X 3/4" PLTD		
20	70088	4	SCR, 10-32 X 1/2 PPHMS SS		

# CONTROL PANEL ASSEMBLY

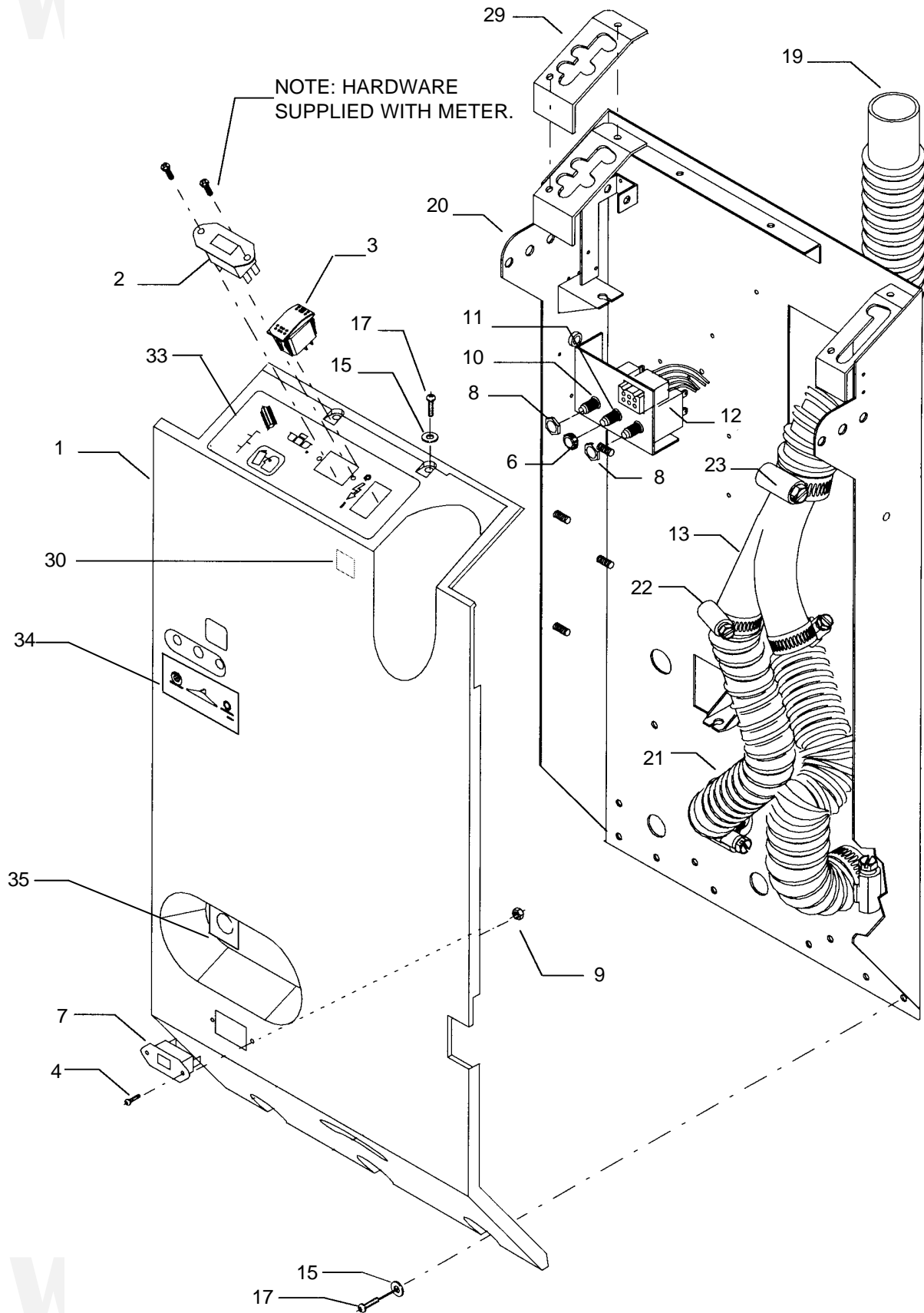



## CONTROL PANEL ASSEMBLY

REF	PART NO.	QTY	DESCRIPTION	SERIAL NO.	NOTES:
1	27710	1	COVER, REAR VOYAGER 2 TRIMMED		
2	54144	1	METER, 36V BATTERY CHARGE LEVEL		
3	72130	2	SWITCH, SPST 2-POSITION ROCKER		
4	70056	2	SCREW, 6-32 X 1/2 PPHMS		
5	OPEN	-	-		
6	57109	1	NUT, 7/16-28 PANEL		
7	54092	2	METER, 0-60 VDC HOUR		
8	57132	2	NUT, 3/8-27 DRESS PANEL		
9	57116	1	NUT, 6-32 W/ STAR WASHER PLTD		
10	14944	1	BREAKER, 16A 250 VAC 50 VDC		
11	14688	1	BREAKER, 35 AMP 50 VDC MTR.		
12	14700	1	BREAKER, 15 AMP BRUSH MTR.		
13	04082	1	ADAPTER, "Y" FITTING MODIFIED		
14	51142	1	LEVER, HANDLE LOCK		
15	87018	4	WASHER, #10 X 9/16 OD		
16	87090	2	WASHER, 1/4 ID X 3/4 OD PLTD		
17	70066	4	SCREW, 10-32 X 3/4 PPHMS		
18	OPEN	-	-		
19	39481	1	HOSE, VAC X 20"		
20	34308	1	FRAME, REAR W/O PLENUM		
21	39313	2	HOSE, 1.5 BLUE VAC X 20"		
22	20063	4	CLAMP, 1.75 WORM GEAR X .312		
23	20046	1	CLAMP, 2.25" WORM GEAR		
24	57032	1	NUT, 3/8-16 SERRATED FLG. PLT.		
25	80604	1	RING, RUE COTTER 1/4"		
26	66133	1	PIN, CLEVIS 3/16" X 7/8" I		
27	67273	1	ROD, VOY HANDLE ADJ.		
28	78271	1	TUBE, VOY HANDLE ADJ.		
29	47200	1	KIT, VOYAGER ADJUSTMENT PLATE		
30	50776	1	LABEL, WARNING FOR SAFTEY		
31	98721	1	SERVICE TAG		NOT SHOWN
32	14382	1	BAND, SERVICE TAG		NOT SHOWN
33	500548	1	LABEL, MAIN SWITCH		
34	500547	1	LABEL, CIRCUIT BREAKER		
35	50540	1	LABEL, VALVE POSITION		

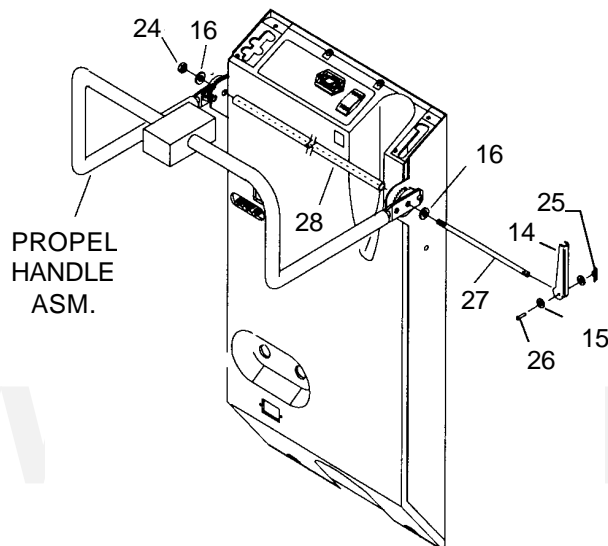

# VAC SHOE ASSEMBLY

WWW.MANUALS.WS

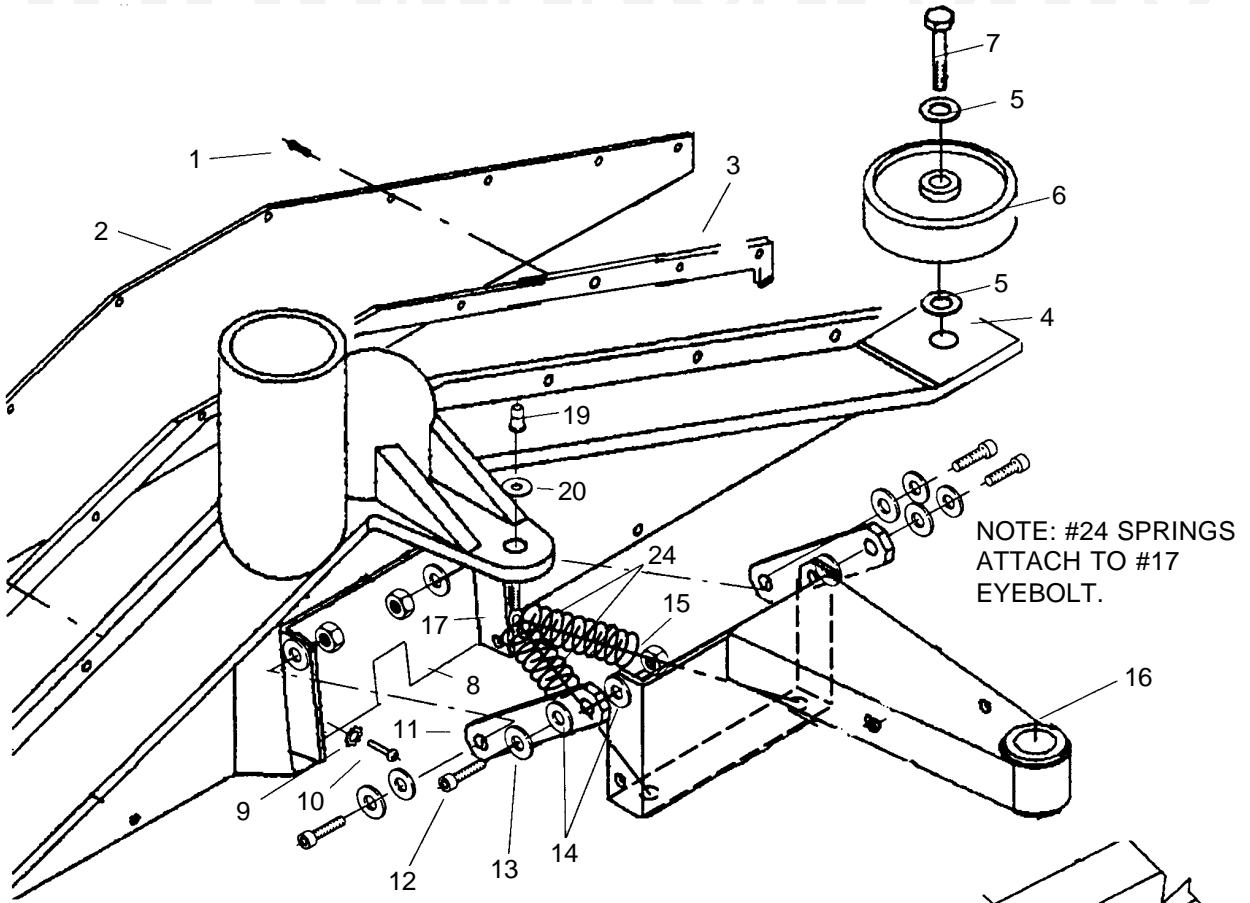

VAC SHOE ASM.  
(REF)

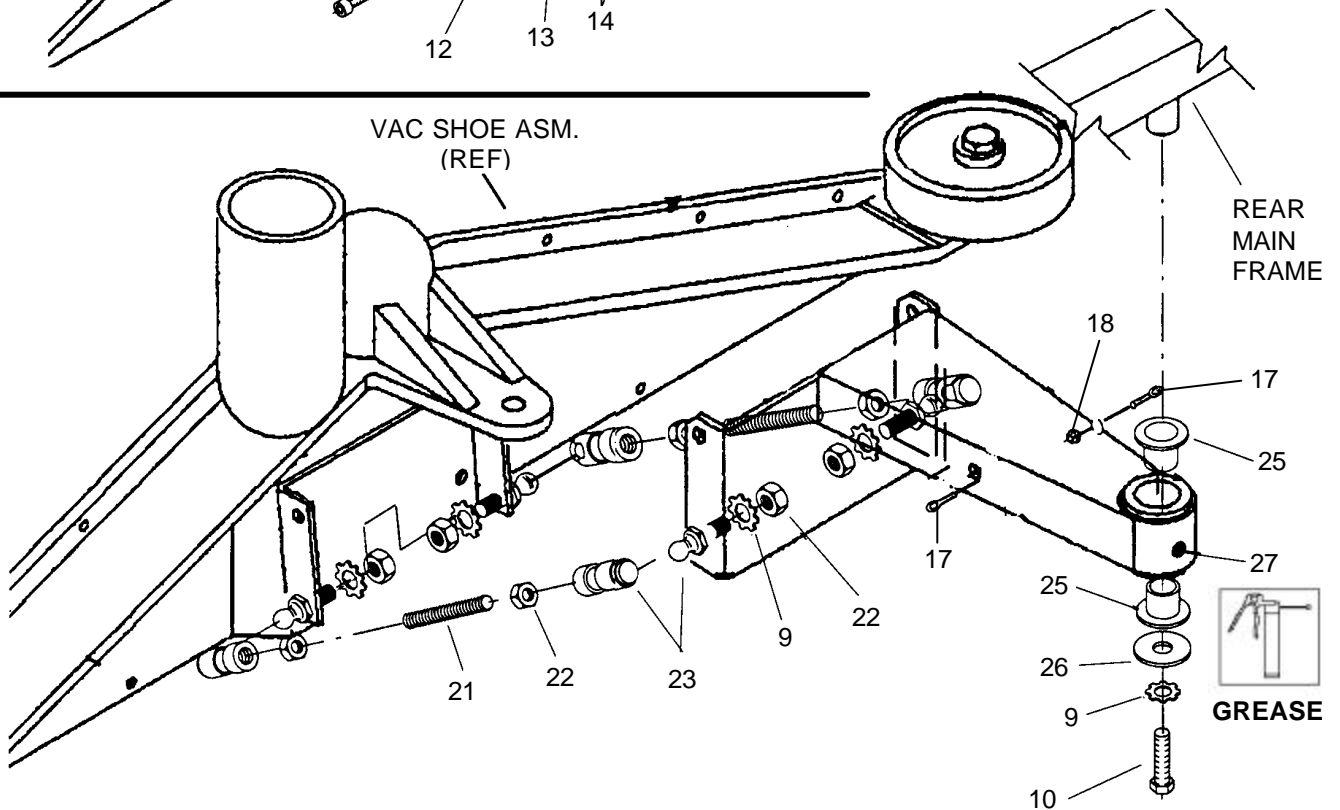

WWW.MANUALS.WS

## VAC SHOE ASSEMBLY

REF	PART NO.	QTY	DESCRIPTION	SERIAL NO.	NOTES:
1	70351	13	SCREW, 10-32 X 3/8 HHTR W/ STAR		
2	62391	1	PLATE, VAC SHOE COVER		
3	35124	1	GASKET, VGR VAC SHOE PLATE		
4	85031	1	VAC SHOE, VGR2 28"		
5	87003	4	WASHER, 3/8 ID X 7/8 OD SS		
6	89059	2	WHEEL, PT20 SQUEEGEE BUMPER		
7	70368	2	SCREW, 3/8-16 X 1-3/4 HHCS		
8	140197	1	BRACKET, VAC SHOE LINKAGE PLTD		
9	87025	9	WASHER, 1/4 LOCK EXT STAR		
10	70011	5	SCREW, 1/4-20 X 5/8 HHCS PLTD		
11	05070	2	ARM ASM, SQUEEGEE		
12	70298	4	SHOULDER BOLT, 5/16 X 3/8L		
13	87029	4	WASHER, 5/16 FLAT SAE		
14	87030	8	WASHER, 3/8 ID X 3/4 OD NYL		
15	57047	4	NUT, 1/4-20 NYLOCK		
16	140192	1	BRACKET ASM, VAC SHOE PIVOT		
17	70263	3	EYEBOLT 8-32 X 1; 1/4 EYE PIT		
18	57026	2	NUT, 8-32 NYLOCK		
19	48031	1	KNOB, VAC SHOE ADJ.		
20	87013	1	WASHER, 1/4 ID X 5/8 OD SS		
21	54-501623	2	RD, 1/4-28 X 2-1/2 SST		
22	57029	12	NUT, 1/4-28 HEX SS		
23	14029	4	BALL JOINT ASM, 1/4-28 HD		
24	73426	2	SPRING, EXT. .43D X 2.50L X .047W		
25	14820	2	BUSHING, FLANGED 3/4 ID X 7/8 OD		
26	87008	1	WASHER, 1/4 ID X 1-1/4 PD PLTD		
27	90006	1	ZERK, GREASE		

### MOUNTING OF VAC SHOE AND CASTER SPRING ASSEMBLY.

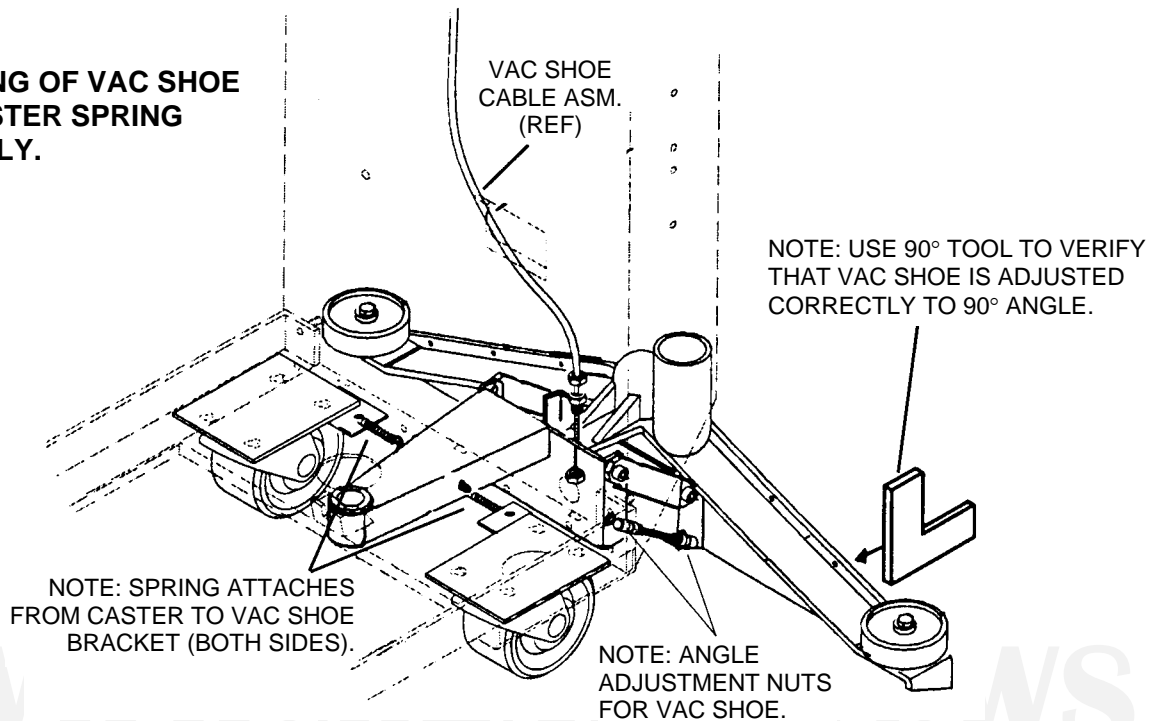

# TANK, COVER & HARDWARE ASSEMBLY

WWW.MANUALS.WS

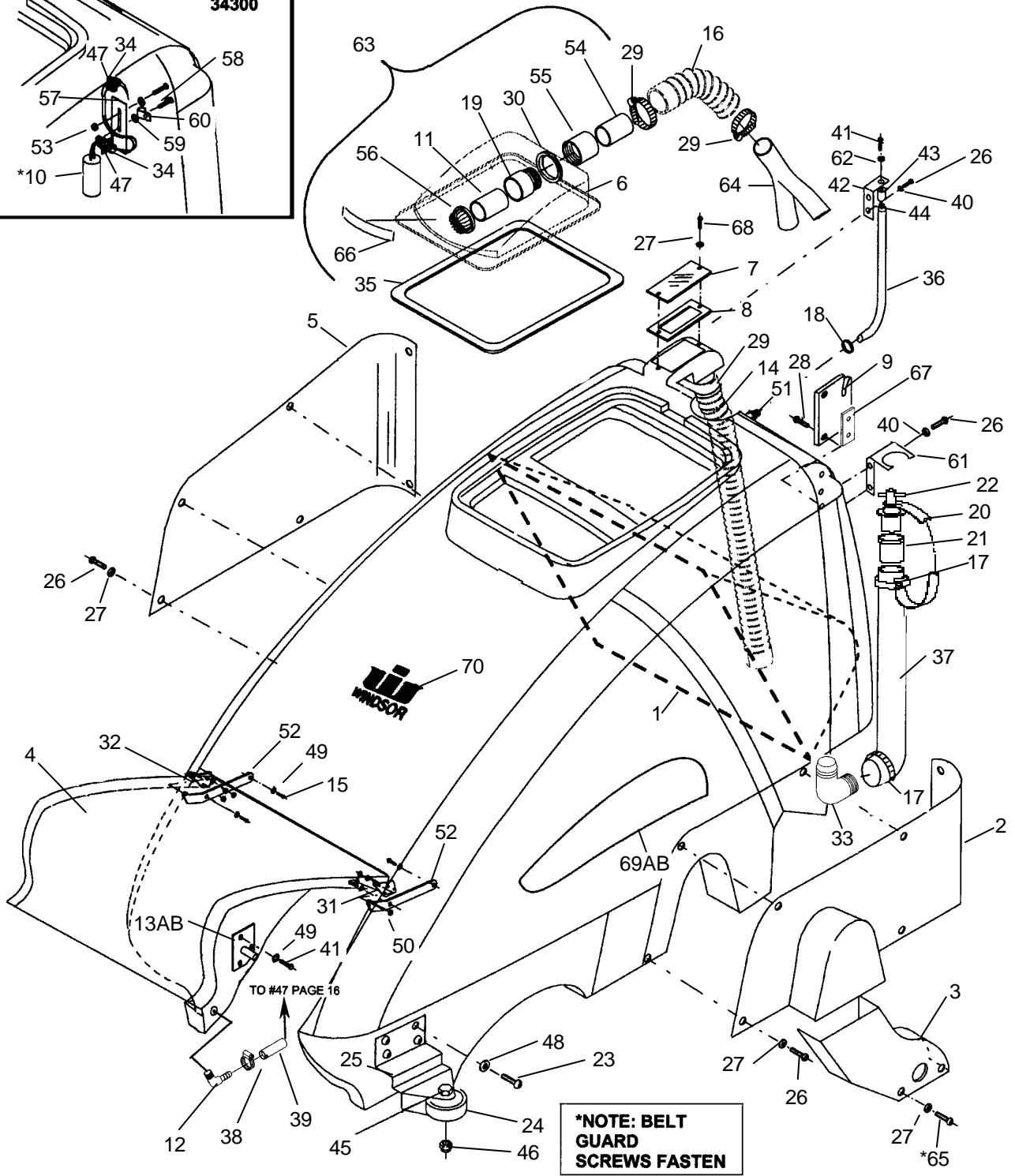
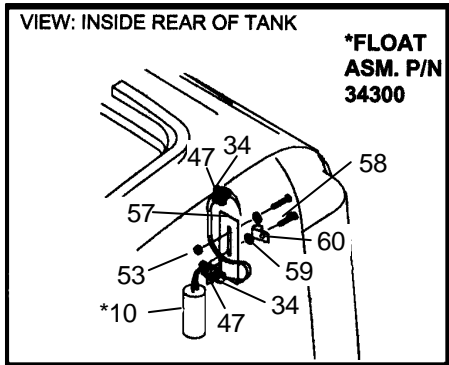

WWW.MANUALS.WS

# TANK, COVER AND HARDWARE PARTS LIST

REF	PART NO.	QTY	DESCRIPTION	SERIAL NO. FROM	NOTES:
1	75393	1	TANK ASM., VGRB W/ DIAPHRAGM		
2	27472	1	COVER, LEFT TANK VGRB		
3	27673	1	COVER, BELT GUARD VGRB		
4	27684	1	COVER, BATTERY COMP.		
5	27473	1	COVER, RIGHT SIDE TANK		
6	28054	1	DOME, VOYAGER TANK		
7	27557	1	COVER, SIGHT WINDOW		
8	35199	1	GASKET, VGR SIGHT WIN		
9	62345	2	PLATE, REAR FRAME TANK MNT		
10	34305	1	FLOAT, SHUT OFF		
11	78122	1	TUBE, 1.5 PVC X 1.88 IN		
12	40090	2	HOSEBARB, 1/4 MPT X 3/8 45°		
13A	66251	1	PIVOT ASM., TANK RIGHT		
13B	66250	1	PIVOT ASM., TANK LEFT		
14	39476	1	HOSE ASM., 2" DIA.		
15	70085	4	SCREW, 1/4-20 X 1/2 PPMHS		
16	39481	1	HOSE, 2" VAC X 20"		
17	20064	2	CLAMP, 2.0" WORM GEAR X .312W		
18	20063	1	CLAMP, 1.75" WORM GEAR X .312		
19	04032	1	ADAPTER, 1.5 MPT X 1.5FS PVC		
20	78499	1	TETHER, DRAIN PLUG		
21	40019	1	HOSEBARB, 1.5 DOUBLE MCHD		
22	66227	1	PLUG, DRAIN HOSE		
23	70481	6	SCREW, 1/4-20 X 3/4 BHCS		
24	89059	2	WHEEL, PT20 SQG. BUMPER		
25	89231	1	BRACKET ASM., GUIDE WHEEL		
26	70361	14	SCREW, 10-32 X 1/2 PHTR PLT		
27	87018	12	WASHER, #10 X 9/16 OD		
28	70201	4	SCREW, 1/4-20 X 3/4 FHMS PLTD		
29	20046	3	CLAMP, 2.25" WORM GEAR		
30	73198	1	SPACER, 2.26 OD X 1.91 ID X 2.51		
31	41305	1	HINGE, VGR DOOR LEFT		
32	41303	1	HINGE, VGR DOOR RIGHT		
33	40036	1	HOSEBARB, 1.5 MPT X 1.5		
34	81379	2	FITTING, SEALED BULKHEAD		
35	35095	1	GASKET, VGRB DOME		
36	39408	1	HOSE, SOL. DRAIN W/ STAMP		
37	39472	1	HOSE, 1.5 DRAIN X 24"		
38	20042	4	CLAMP, 3/8 ID HOSE		
39	39451	2	HOSE, 3/8 NYLOBRAID X 11		
40	87016	4	WASHER, #10 LCK EXT STAR		
41	70011	5	SCREW, 1/4-20 X 5/8 HHCS		
42	14899	1	BRACKET, DRAIN HOSE PLUG		
43	40053	1	HOSEBARB, SOL. HOSE MTG		
44	57047	1	NUT, 1/4 X 20 NYLOCK PLTD		
45	70368	2	SCREW, 3/8-16 X 1.75 HHMS		
46	57022	2	NUT, 3/8-16 LOCK SS		
47	57044	2	NUT, HEX BRASS 3/8 NPT		
48	87151	6	WASHER, 1/4 SPLIT LOCK		
49	87025	8	WASHER, 1/4 LOCK EXT STAR SS		
50	57236	2	NUT, 10-32 HEX NYLOCK BLK.		
51	40051	1	HOSEBARB, 3/4 MPT X 1" HOSE PV		
52	41304	2	BRACKET, VOYAGER HINGE		
53	57104	8	NUT, 10-24 W/ STAR WASHER		
54	78211	1	TUBE, 1.5 PVC X 3.31		
55	04075	1	ADAPTER, 1.5 FPT X 1.5 FS PVC		
56	34140	1	FILTER, VAC INTAKE 10 MESH		
57	140193	1	BRACKET, VGR FLOAT		
58	70209	2	SCR, 10-32 X 1.75 PHME PLTD		
59	87131	2	WASHER, #80R #10 FLAT W/NEO.		
60	20005	1	CLAMP, 5/16 NYLON		
61	140194	1	BRACKET, RECOVERY HOSE MTG.		
62	87013	1	WASHER, 1/4 ID X 5/8 OD SS		
63	28056	1	DOME ASM., VGR2		
64	04082	1	ADAPTOR, Y-FITTING MODIFIED		
65	70088	2	SCREW, 10-32 X 1/2 PPHMS		
66	500009	1	LABEL, WARNING EXPLOSION		
67	66380	3	PLATE, SPACER		
68	70114	2	SCR, #10 X 3/4 TYPE B		
69A	50917	1	LABEL, TANK RIGHT		
69B	50918	1	LABEL, TANK LEFT		
70	50941	1	LABEL, WINDSOR LOGO		

# WIRING DIAGRAM VOYAGER 2

WWW.MANUALS.WS

