

tethys  
H10

# OPERATOR'S MANUAL



## REVISIONS

The following table lists the subsequent editions/revisions of the manual.  
The field "Description" summarizes the topic of the last revision.

Code	Rev	Date	Description
97050759	00	01-2015	First issue – ORIGINAL LANGUAGE
97050759	01	05-2015	Adaptation of texts and images
97050759	02	04-2016	Adaptation of texts and images
97050759	03	12-2016	Adaptation of texts and images
97050759	04	08-2019	Adaptation of texts and images
97050759	05	07-2020	Adaptation of texts and images
97050759	06	05-2021	Adaptation of texts and images

## CONTENTS

### Contents

CONTENTS .....	2
FOREWORD.....	4
SYMBOLS USED .....	4
SYMBOLS ON THE EQUIPMENT .....	4
RELEVANT EUROPEAN DIRECTIVES.....	4
TECHNICAL STANDARDS .....	5
INTENDED USE .....	5
PURPOSE OF THE MANUAL.....	5
GENERAL WARNINGS.....	6
INFORMATION ON RISK MITIGATION.....	6
PACKAGE CONTENT .....	8
DIMENSION AND WEIGHT .....	8
DESCRIPTION OF THE CONTENT .....	9
PRODUCT HANDLING .....	10
EMPTYING OF DETERGENT RESERVOIR AND WATER CIRCUIT .....	10
PRODUCT PRESENTATION .....	11
GENERAL CHARACTERISTICS .....	11
LCD ICONS .....	13
EXAMPLE OF WORKING CYCLE .....	13
SETTING UP THE DEVICE.....	15
FOREWORD .....	15
FOOT ADJUSTMENT.....	16
GENERAL PRECAUTIONS FOR INSTALLATION .....	16
ELECTRICAL CONNECTIONS.....	17
HYDRAULIC SET-UP.....	18
WATER FILLING .....	18
HYDRAULIC SYSTEM REQUIREMENTS.....	18
MAINS WATER .....	19
WATER DRAINAGE.....	20
FIRST START-UP .....	21
DOOR OPENING .....	21
BASKET EXTRACTION AND INSERTION .....	22
FILLING OF SALT RESERVOIR.....	23
FILLING OF DETERGENT RESERVOIR.....	24
VALIDATED DETERGENTS .....	24
DOOR CLOSING .....	25
FIRST START-UP .....	26
DISPLAYED PROCEDURE UPON FIRST START-UP .....	26
MAIN MENU .....	27
CONFIGURATION.....	28
SETTINGS.....	28
PREPARATION OF THE MATERIAL.....	42
PREPARING THE MATERIAL FOR HANDPIECES H CYCLE .....	44
CYCLES.....	45
THERMAL DISINFECTION CYCLE (D90).....	45

WASHING CYCLE (W).....	47
PRE-WASHING CYCLE.....	48
CUSTOM CYCLES.....	50
THERMAL DISINFECTION CYCLES SET BY THE USER (D1 CUSTOM, D2 CUSTOM).....	50
WASHING CYCLE DEFINED BY THE USER (W1 CUSTOM).....	52
HANDPIECES THERMAL DISINFECTION CYCLE (HANDPIECES H).....	53
DRYING FUNCTION.....	57
DELAYED START FUNCTION.....	58
EXECUTION OF THE CYCLE.....	59
CYCLE OUTCOME.....	59
DOOR OPENING AT THE END OF THE CYCLE.....	60
MANUAL INTERRUPTION.....	60
DATA MANAGEMENT.....	61
APPENDIX - TECHNICAL CHARACTERISTICS.....	67
SUMMARY TABLE.....	67
SAFETY DEVICES.....	68
SUMMARY TABLE OF CYCLES.....	69
PROGRAMMES SCHEME.....	72
APPENDIX - MAINTENANCE.....	73
FOREWORD.....	73
ORDINARY MAINTENANCE PROGRAMME.....	73
SCHEDULED MAINTENANCE MESSAGES.....	74
DESCRIPTION OF MAINTENANCE INTERVENTIONS.....	74
CLEAN THE GASKET.....	75
CLEAN EXTERNAL SURFACES.....	75
CLEAN WASHING CHAMBER.....	75
CLEAN CHAMBER FILTERS.....	76
HEPA FILTER REPLACEMENT.....	77
CLEAN THE ROTARY NOZZLE.....	77
PERIODIC THERMO-DISINFECTOR VALIDATION.....	78
DEVICE USEFUL LIFE.....	79
DISPOSING THE EQUIPMENT WHEN NO LONGER USED.....	79
APPENDIX - GENERAL PROBLEMS.....	80
FOREWORD.....	80
TROUBLESHOOTING.....	81
APPENDIX – ALARMS.....	82
FOREWORD.....	82
ALARM INTERVENTION.....	82
SYSTEM RESET.....	83
TROUBLESHOOTING.....	84
APPENDIX - ADMIN USER PIN RESET.....	95
APPENDIX - TECHNICAL SERVICE.....	96

## FOREWORD





## SYMBOLS USED





## SYMBOLS ON THE EQUIPMENT

## RELEVANT EUROPEAN DIRECTIVES

Dear Customer,

Thank you for choosing this product. We hope that you will find it completely satisfactory. This manual describes all procedures for the correct use of the device and instructions for deriving the full benefit from its features. In any case, we will be available to provide explanations and to receive any suggestions you may have for improving our products or services.

	<b>NOTE</b>
	PAY PARTICULAR ATTENTION TO THE PARAGRAPHS MARKED WITH THE SYMBOL SHOWN.
	<b>WARNING</b>
	POTENTIAL DANGER TO PROPERTY. FOLLOW THE INSTRUCTIONS IN THE MANUAL TO PREVENT POTENTIAL DAMAGE TO MATERIALS, EQUIPMENT AND/OR OTHER PROPERTY.
	<b>HAZARD</b>
	THIS SYMBOL INDICATES A POTENTIAL DANGER TO PERSONS. FOLLOW THE PROCEDURES DESCRIBED IN THE MANUAL IN ORDER TO AVOID INJURING THE USER AND/OR OTHERS.
	<b>HAZARD</b>
	THIS SYMBOL INDICATES A POTENTIAL DANGER DUE TO HIGH TEMPERATURE.
	
	THE MATERIALS THE DEVICE IS COMPOSED OF MUST BE DISPOSED OF ACCORDING TO THE DIRECTIVE 2012/19/EU.

	Potential danger due to high temperature.
	Device complying with applicable directives.
	Disposal symbol in accordance with Directive 2012/19/EU.
	Refer to the user manual.

The product described in this manual is manufactured in accordance with the highest safety standards and doesn't represent any danger for the operator if used according to the following instructions. The product is **complying** with the following **European Directives as applicable**:

- 93/42/EEC, and subsequent amendments and additions, concerning medical devices.
- 2011/65/EU, (Rohs II) on restriction of hazardous substances in electrical and electronic equipment.

## TECHNICAL STANDARDS

The device complies with Standards ISO 15883-1 and ISO 15883-2 on Washers/Disinfectors and with Electric Safety Standards IEC 61010-1 and IEC 61010-2-040.

## INTENDED USE

### DEVICE FOR PROFESSIONAL USE ONLY - NOT INTENDED FOR RETAIL SALE.

The product is intended exclusively for washing and thermal disinfection of reusable surgical instruments capable of withstanding a temperature of at least 80°C, with or without ultrasonic treatment depending on the cycle.

It is intended for non-ultrasonic washing and disinfection of the external surfaces of rotary instruments only if used in combination with the special accessory, unless such instruments are explicitly designated as not suitable for thermal disinfection and washing by the manufacturer.

It is not intended for the washing and disinfection of internal ducts of reusable surgical instruments that have deep cavities with reduced opening.

It is not intended for the washing and/or disinfection of electronic instruments, unless explicitly indicated as suitable for thermal disinfection and washing by the manufacturer.

It is not intended for the washing and thermal disinfection of thermolabile medical devices.

It is not intended for the washing of instruments made of non-protected aluminium or with decorative anodising.

#### WARNING



THE DEVICE CAN BE USED ONLY BY SKILLED PERSONNEL. UNDER NO CIRCUMSTANCES IT CAN BE USED OR HANDLED BY UNSKILLED AND/OR UNAUTHORISED PERSONNEL.

#### WARNING



THE DEVICE IS NOT A MOBILE OR PORTABLE DEVICE.

#### WARNING



THE TREATMENT IN THE INSTRUMENT WASHER CAN NEVER REPLACE STERILIZATION. DISINFECTION IN THE INSTRUMENT WASHER AIMS AT REDUCING THE RISK OF INFECTION OF PERSONNEL HANDLING THE INSTRUMENTS DURING THE RECONDITIONING PROCESS.

#### NOTE



INFORMATION CONTAINED IN THIS MANUAL IS SUBJECT TO CHANGE WITHOUT PRIOR NOTICE.

THE MANUFACTURER IS NOT RESPONSIBLE FOR DIRECT, INDIRECT OR ACCIDENTAL DAMAGE RESULTING FROM OR RELATING TO THE PROVISION OR USE OF THIS INFORMATION.

THIS DOCUMENT MAY NOT BE REPRODUCED, ADAPTED OR TRANSLATED, IN PART OR IN FULL, WITHOUT THE PRIOR WRITTEN PERMISSION OF THE MANUFACTURER.

## PURPOSE OF THE MANUAL

The purpose of this manual is to provide instructions for:

- becoming generally familiar with the product;
- its correct installation and configuration;
- its safe, efficient use;
- handling materials before and after washing and/or disinfection.

Its appendixes also provide:

- the product's general technical specifications;
- washing and/or disinfection programme specifications;
- maintenance operations;
- Troubleshooting.

## GENERAL WARNINGS

When using this product, **always** follow the instructions in the manual and never use it for anything other than its intended purpose.



### WARNING

USER IS RESPONSIBLE FOR THE CORRECT AND REGULAR INSTALLATION, USE AND MAINTENANCE OF THE DEVICE. IN CASE OF WRONG INSTALLATION OR USE OR IN CASE OF FAILED OR WRONG MAINTENANCE, THE MANUFACTURER WILL NOT BE RESPONSIBLE FOR ANY MALFUNCTION, FAILURE OR BREAKAGE, PROPERTY DAMAGE OR INJURIES.

Please observe the following precautions in order to avoid injury or property damage:



### WARNING

THE USE OF WATER OF INADEQUATE QUALITY CAN SEVERELY DAMAGE THE DEVICE.  
SEE TECHNICAL CHARACTERISTICS APPENDIX IN THIS REGARD.

- Do **not** pour water or other fluids on the device;
- Do **not** pour flammable substances on the device;
- Do **not** use the device in the presence of gases or explosive or inflammable vapours;
- Before performing any maintenance or cleaning intervention **ALWAYS DISCONNECT** power supply.
- Make sure the electrical system is **grounded** according to current laws and/or standards;;
- Do **not** remove any label or nameplate from the device; request new ones, if necessary;
- Use **only original spare parts**.



### WARNING

FAILURE TO COMPLY WITH THE ABOVE RELEASES THE MANUFACTURER FROM ALL LIABILITY.

## INFORMATION ON RISK MITIGATION

### FOR THE USER

- **Contamination due to improper handling of the load**  
See chapter PREPARING THE MATERIAL.

- **Burn by contact with hot surfaces or fluids**

It is necessary to:

- Always wear PPE suitable for the handling of hot material and gloves of appropriate material and thickness
- Clean your gloved hands with a germicide detergent
- Avoid any contact of trays and material with contaminated and/or non-heat-resistant surfaces
- Handle the material making sure not to damage any packages, bags and containers serving as a barrier

- **Crushing fingers**

Close the door gently.

See the chapter CLOSING THE DOOR.

### FOR THE PATIENT

- **Contamination due to missing or wrong scheduled maintenance**

The thermal disinfectant periodically displays warning messages relevant to "routine" maintenance operations that must be carried out in order to ensure the proper operation of the device.

- **Contamination due to missing periodic validation**

See the chapter APPENDIX - MAINTENANCE.

## PACKAGE CONTENT

## DIMENSION AND WEIGHT



### NOTE

CHECK THE INTEGRITY OF THE PACKAGE UPON RECEIPT.

Once the package is opened, check that:

- the supply matches the specifications of the order (see the delivery note);
- there is no visible damage to the product;

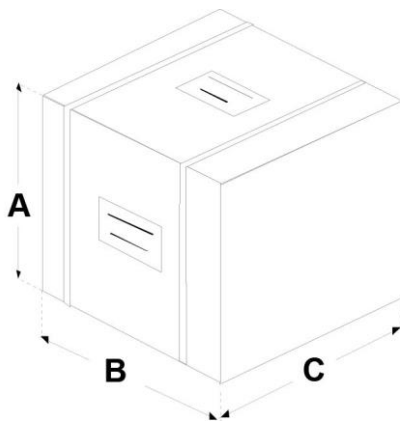

### **Dimensions and weight**

A. Height	600 mm
B. Width	600 mm
C. Depth	700 mm
Total weight	47 kg



### NOTE

IN CASE OF WRONG DELIVERY, MISSING PARTS OR ANY TYPE OF DAMAGE, INFORM IMMEDIATELY AND IN DETAIL THE RESELLER AND THE CARRIER THAT MADE THE DELIVERY.

## DESCRIPTION OF THE CONTENT

In addition to the thermal disinfecter, the package contains:

1. Operator's documents (with USB support)
2. Detergent package
3. Drain pipe
4. Detergent filling funnel
5. Detergent tank filling container
6. Salt filling funnel
7. Allen wrench for HEPA filter replacement
8. Wrench for rotary nozzle maintenance
9. HEPA filter certificate of conformity
10. Basket support
11. Baskets
12. instrument holder kit
13. No.2 ties for drain pipe
14. Drills box

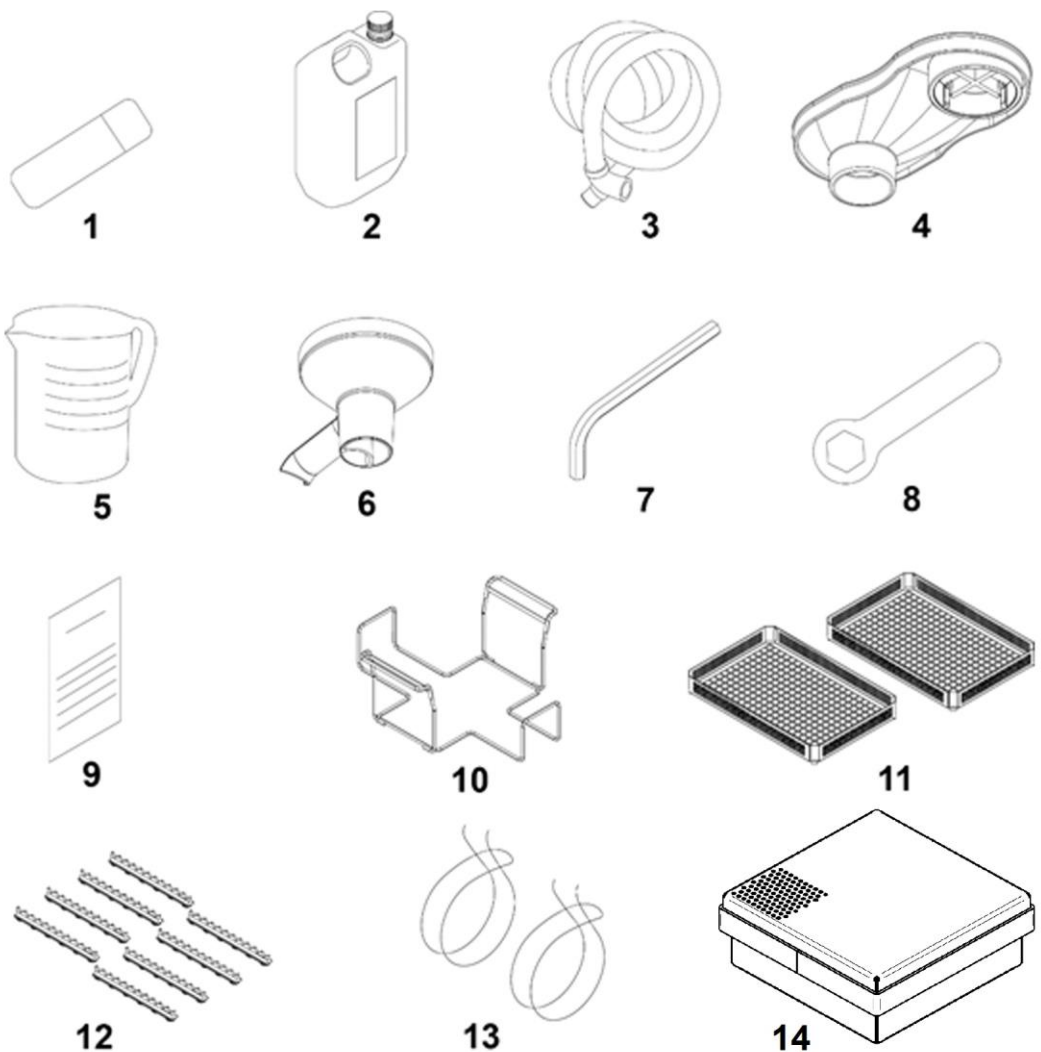

## PRODUCT HANDLING

Thermo-disinfector removal from package and lifting operations must be carried out by two persons. Handle the device with a truck or suitable means.



### WARNING

WE RECOMMEND TO TRANSPORT AND STORE THE DEVICE AT A TEMPERATURE NOT BELOW 5°C. EXTENDED EXPOSURE TO LOW TEMPERATURES MAY DAMAGE THE PRODUCT.



### NOTE

KEEP THE ORIGINAL PACKAGE AND USE IT WHENEVER THE DEVICE IS TO BE TRANSPORTED. THE USE OF A DIFFERENT PACKAGE MIGHT DAMAGE THE PRODUCT DURING SHIPMENT.

## EMPTYING OF DETERGENT RESERVOIR AND WATER CIRCUIT

Before any transport following the first installation, it is necessary to empty the detergent reservoir.



### WARNING

FOR FURTHER INFORMATION ABOUT RESERVOIR EMPTYING PROCEDURE, PLEASE CONTACT THE TECHNICAL SERVICE DEPARTMENT (SEE APPENDIX).

If salt is present inside resin regeneration reservoir, some salt solution could leak out of thermo-disinfector water filling pipe.

Water evaporation could result in the creation of salt crystals around water filling union. To eliminate salt deposits, rinse with water and dry.

## PRODUCT PRESENTATION

**Tethys H10** thermo-disinfector is the revolutionary proposal in the field of thermal disinfection, as well as the new point of reference in terms of safety, performance, efficiency and ease of use.

It is a sophisticated but, at the same time, easy to use device that, thanks to its wide range of configuration options, meets any need of washing and disinfection of medical equipment, ensuring the maximum performance in any conditions.

Thanks to its extreme ease of use, small size and pleasant appearance, it is the ideal partner for all professionals who require maximum functionality and safety of the washing and thermal-disinfection process.

## GENERAL CHARACTERISTICS

**Tethys H10** is an electronic thermal disinfector, entirely operated by a micro-processor. The exclusive disinfection system, the effective hydraulic circuit and the electronic management (integrated by high-precision sensors) ensure a process high execution speed and an excellent stability of thermodynamic parameters.

Moreover, its Process Evaluation System constantly monitors all the machine's "vital" parameters in real-time, guaranteeing absolute safety and a perfect result.

It offers users 6 programmes, some of which provided with customisable drying, optimised for the fast and effective disinfection of the various types of loads (instruments and materials) used in a medical environment.

All the cycles can immediately be selected on the clear LCD touch screen, which also allows extensive configuration of the device according to the user's needs.

For further details please refer to '**Configuration**' chapter.

The new thermal disinfector **Tethys H10** has the most complete, sophisticated and advanced safety systems available today, to ensure the user against any operational, electrical, mechanical, thermal or functional fault.

### **NOTE**



FOR THE DESCRIPTION OF SAFETY DEVICES, REFER TO TECHNICAL CHARACTERISTICS APPENDIX.

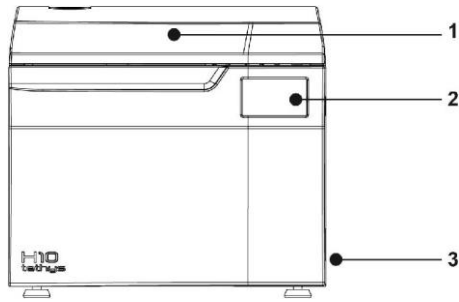

1. Door
2. Control panel and LCD screen
3. Power switch

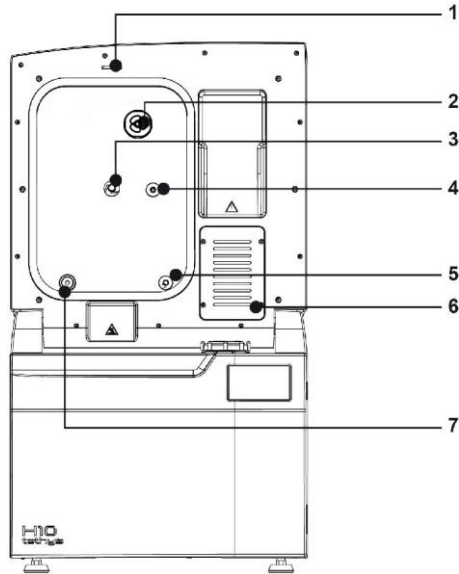

1. Door locking system
2. Air inlet
3. Rotary nozzle
4. Detergent inlet
5. Decalcified water inlet
6. HEPA filter
7. Temperature probe input (process validation)

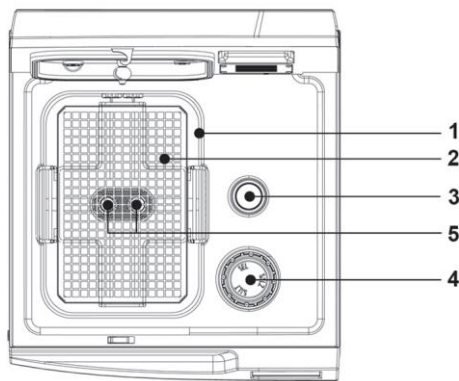

1. Stainless steel chamber
2. Stainless steel basket
3. Detergent tank
4. Salt tank
5. Chamber drain filter

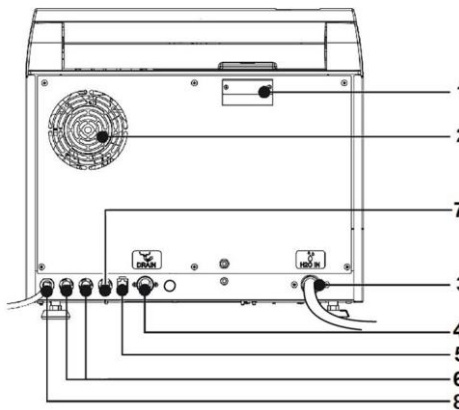

1. Air / vapour outlet
2. Cooling fan
3. Hose for connection to the mains water with "Aquastop" system
4. Water drain connection
5. Ethernet connection
6. Network fuses
7. Pump fuse
8. Power cable

## LCD ICONS

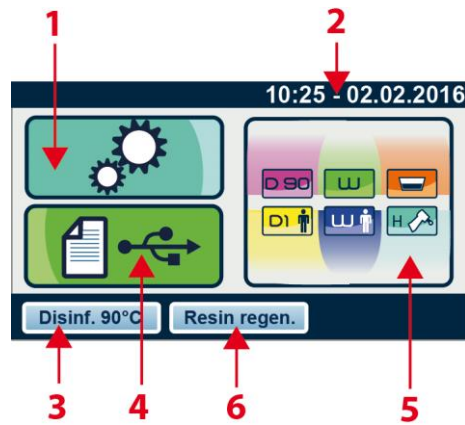

1. SETTINGS
2. TIME AND DATE
3. LAST CYCLE PERFORMED
4. DATA MANAGEMENT
5. WASHING AND DISINFECTION CYCLES
6. LAST STARTED CYCLE OF THE "OTHER CYCLES" MENU

	Management of thermo-disinfector settings
	Management of data and information
	Menu of washing and disinfection cycles

### NOTE

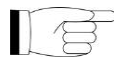

OTHER PARTICULAR SYMBOLS RELATING TO THE VARIOUS CONDITIONS OF USE WILL BE DESCRIBED IN THE RELATIVE PARAGRAPHS.

## EXAMPLE OF WORKING CYCLE

The disinfection programme of Tethys H10 series can be effectively described as a succession of phases, each one with a very precise purpose.  
Example of washing cycle with ultrasounds and disinfection:

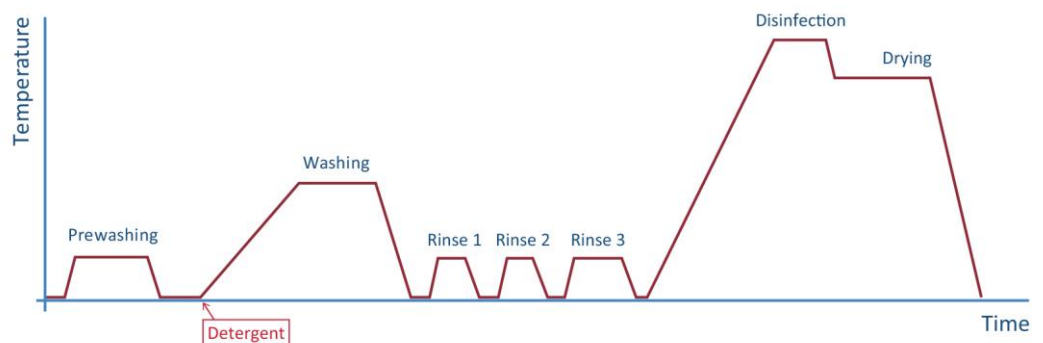

WASHING TIME means the period of time between the reaching of set washing temperature and drainage start.

### NOTE

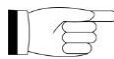

PLEASE REFER TO PROGRAMMES APPENDIX FOR MORE DETAILS ON THE DIFFERENT AVAILABLE PROGRAMMES.

### WARNING



AT THE END OF THE CYCLE IT IS ESSENTIAL TO VISUALLY INSPECT THE OBJECTS TO CHECK THEIR PROPER WASHING.

## SETTING UP THE DEVICE FOREWORD

The first and essential step for a proper and safe operation of the thermal disinfector, its durability and complete use of its features is a correct installation, through the thorough compliance with these instructions.

### NOTE



TECHNICAL SERVICE DEPARTMENT (SEE APPENDIX) IS AVAILABLE FOR ANY DOUBT OR FURTHER INFORMATION.

### Installation dimensions

Height (with door fully open)	835 mm
Height (with door at the minimum opening) *	710 mm
Width	440 mm
Installation depth	560 mm
Total weight under work conditions	50 kg

\* The door is designed to remain stable even at the minimum opening, ensuring a correct access to the chamber and allowing easy insertion and/or removal of the instrument baskets.

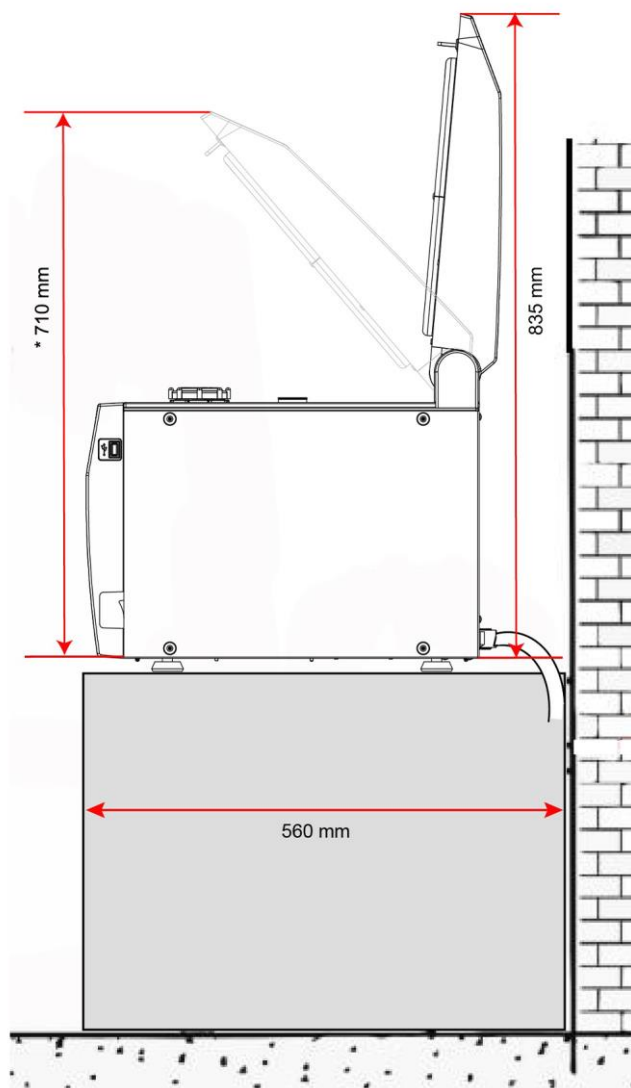

## FOOT ADJUSTMENT

Check the correct levelling of the device by means of a spirit level positioned on the surface along the sides of the chamber.

If necessary act on the adjustable feet (as shown in the figure), checking the levelling.

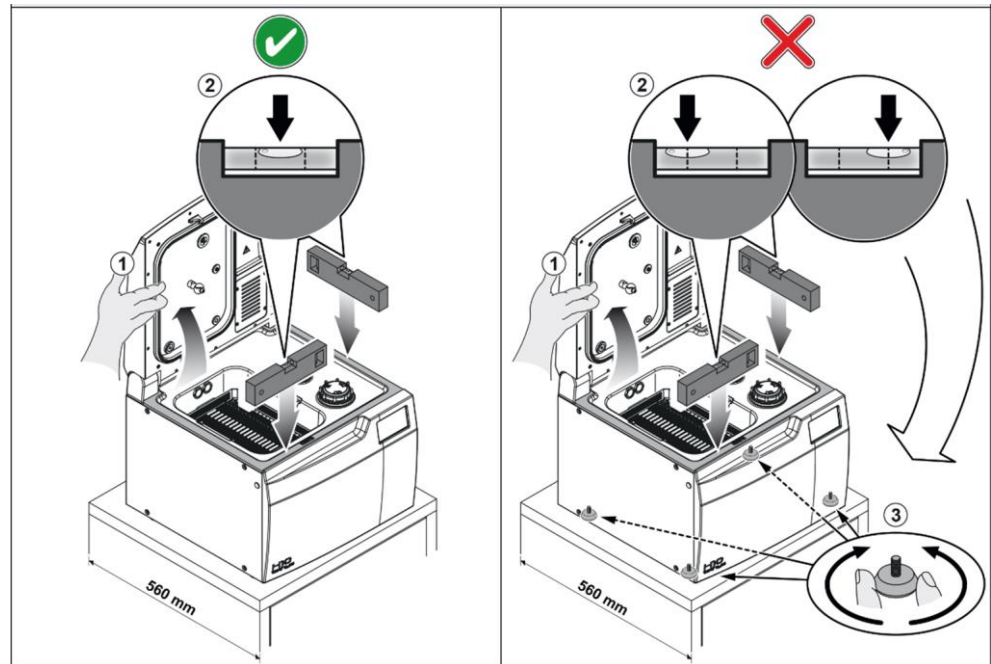

## POWER SUPPLY

The electric system to which the thermal disinfecter will be connected must be suitably dimensioned according to the electrical characteristics of the device. This information is shown on the **back of the machine**.

## GENERAL PRECAUTIONS FOR INSTALLATION

To ensure a correct operation of the device and/or avoid risk situations, respect the following **warnings**:

- Make sure that the support surface is strong enough to support the device weight during operation (approx. 50 kg);
- Leave adequate room for ventilation all around the thermal disinfecter, in particular by leaving at least 10 cm in the back area.
- Do not install the thermal disinfecter too close to chambers, sinks or similar places, thus avoiding contact with water or liquids. This could cause short circuits and/or potentially dangerous situations for the operator;
- Do not install the thermal disinfecter in excessively humid or poorly ventilated environments;
- Do not install the machine in environments with flammable and/or explosive gases or vapours;
- Install the device so that the power cable is not bent or squeezed. It must freely run all the way to the electrical outlet.
- Install the device so that the filling/drain pipes are not bent or squeezed.



### WARNING

THE SAFETY OF ANY SYSTEM WHICH INTEGRATES THE DEVICE IS THE RESPONSIBILITY OF THE SYSTEM ASSEMBLER.

## ELECTRICAL CONNECTIONS

The thermo-disinfector must be connected to a socket of the electric system having adequate capacity for the absorption of the device and properly earthed, in accordance with laws and/or regulations in force.

The socket must be properly protected through magneto-thermal and differential circuit breakers having the following characteristics:

Rated current $I_n$	230-240V/50Hz	10 A
	220V/60Hz	10 A
	120V/60Hz	15 A
Residual current $I_{\Delta n}$	230-240V/50Hz	0.03 A
	220V/60Hz	
	120V/60Hz	

### **WARNING**



THE MANUFACTURER IS NOT RESPONSIBLE FOR DAMAGES CAUSED BY THE INSTALLATION OF THE THERMO-DISINFECTOR WITH UNSUITED ELECTRIC SYSTEMS AND/OR NOT PROPERLY EARTHED.

### **NOTE**



ALWAYS CONNECT THE POWER CORD DIRECTLY TO THE POWER OUTLET.  
DO NOT USE EXTENSIONS, ADAPTERS OR OTHER ACCESSORIES.

### **WARNING**



IT IS ESSENTIAL THAT THE ELECTRIC SYSTEM TO WHICH THE MACHINE IS CONNECTED COMPLIES WITH THE REGULATION IN FORCE.

### **WARNING**



ANY ELECTRIC CHECKS AND PREPARATION OF SYSTEMS MUST BE WORKMANLIKE PERFORMED BY SKILLED PERSONNEL, HAVING PROVEN EXPERTISE AND AUTHORIZED TO OPERATE ON ELECTRIC SYSTEMS.  
COMPETENT STAFF SHALL CHECK THAT EARTH CONNECTION IS EFFICIENT.

## HYDRAULIC SET-UP WATER FILLING

### WATER INLET CONNECTION

The device is equipped with mains water filling pipe.  
The filling pipe, with integrated "Aquastop" system serving as a protection against any water leak, is pre-set for cock connection with 3/4" gas threaded connector.

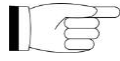

#### NOTE

CHECK WHETHER CURRENT REGULATIONS REQUIRE THE INSTALLATION OF A WATER BACKFLOW PREVENTER TO THE MAINS. IF NECESSARY, PROCEED WITH THE INSTALLATION OF THE DEVICE.

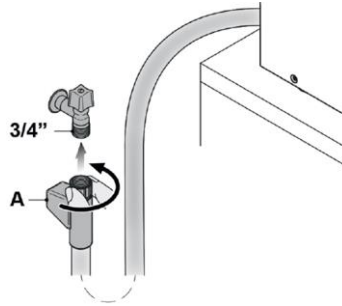

#### NOTE

IF FILLING PIPE MUST CROSS A TOP, ARRANGE A D=75 mm HOLE. MINIMUM HOLE D=65 mm REQUIRES THE REMOVAL OF AQUASTOP SOLENOID VALVE SHELL (A).

### POSITIONING OF FILLING COCKS

Filling cocks must be positioned near the device, easily accessible by the user.  
For the positioning of filling cock there are no special constraints of height, except the length of the supplied pipes, approx. 2 metres.



#### NOTE

TO PREVENT THE RISK OF CLOGGING OR DAMAGE, IF WATER PIPELINE IS NEW OR HAS BEEN INACTIVE FOR A LONG TIME, MAKE SURE THAT WATER IS CLEAR AND WITHOUT CONTAMINATION BEFORE CARRYING OUT WATER CONNECTION

## HYDRAULIC SYSTEM REQUIREMENTS

Check that the water supply pressure is within the required limits:

- min. pressure 2 bar
- max. pressure 5 bar.

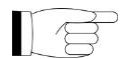

#### NOTE

TO PREVENT FLOODING AFTER ANY FAILURE, IT IS RECOMMENDED TO CLOSE THE MAINS WATER COCK WHENEVER THE DEVICE IS NOT OPERATING, ESPECIALLY AT NIGHT.

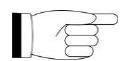

#### NOTE

THE DEVICE MUST NOT BE CONNECTED TO ANY WATER SUPPLY COMING FROM OSMOSIS SYSTEMS.

## MAINS WATER

A connection to a "drinkable" water mains providing water with maximum hardness of 54°f, and total dissolved iron content, Fe<sup>2+</sup> and Fe<sup>3+</sup>, not exceeding 0.5 ppm is required for the operation of the machine.

Measure the hardness value of mains water, expressed in French degrees (°f), using the appropriate kit or an equivalent device.

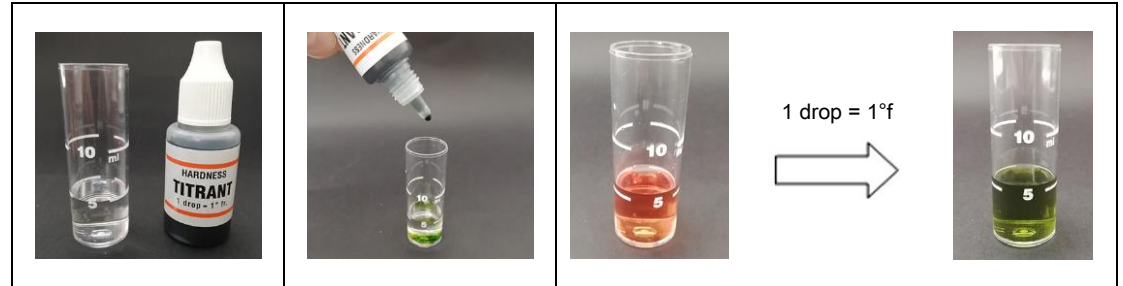

The measured value must be set in the dedicated menu, displayed upon device first switching on, by selecting the corresponding range of values.

The selected range of hardness values determines the resin regeneration frequency of the integrated softener. Thermal disinfecter disables resin regeneration if water hardness set value is lower than 10°f (See WATER HARDNESS paragraph).

### NOTE

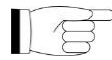

IF MAINS WATER CONTAINS A QUANTITY OF FE<sup>2+</sup>/FE<sup>3+</sup> IRON EXCEEDING 0.5 PPM AND/OR MAINS WATER HARDNESS EXCEEDS 54°f (FRENCH DEGREES), A PRE-TREATMENT OF WATER MUST BE CARRIED OUT BY INSTALLING A IRON REMOVAL AND/OR SOFTENING SYSTEM UPWARDS.

### NOTE



IF A SOFTENING SYSTEM IS ALREADY AVAILABLE ON SITE, CONNECTED TO MAINS WATER AND ABLE TO SUPPLY WATER WITH MAXIMUM HARDNESS OF 10°f, MEASURE THE VALUE IN FRENCH DEGREES (°f) OF MAINS WATER HARDNESS AND SET THE CORRESPONDING HARDNESS VALUE IN THE RELEVANT MENU. THE THERMAL DISINFECTOR DISABLES RESIN AUTOMATIC REGENERATION IF WATER HARDNESS SET VALUE IS LOWER THAN 10°f.  
SEE INSTRUCTIONS IN "WATER HARDNESS" SECTION

## WATER DRAINAGE

### Drain pipe of the device:

rubber end for hose fitting diameter 19-22 mm (1/2").

### WATER DRAIN CONNECTION

The device is equipped with a drain pipe.

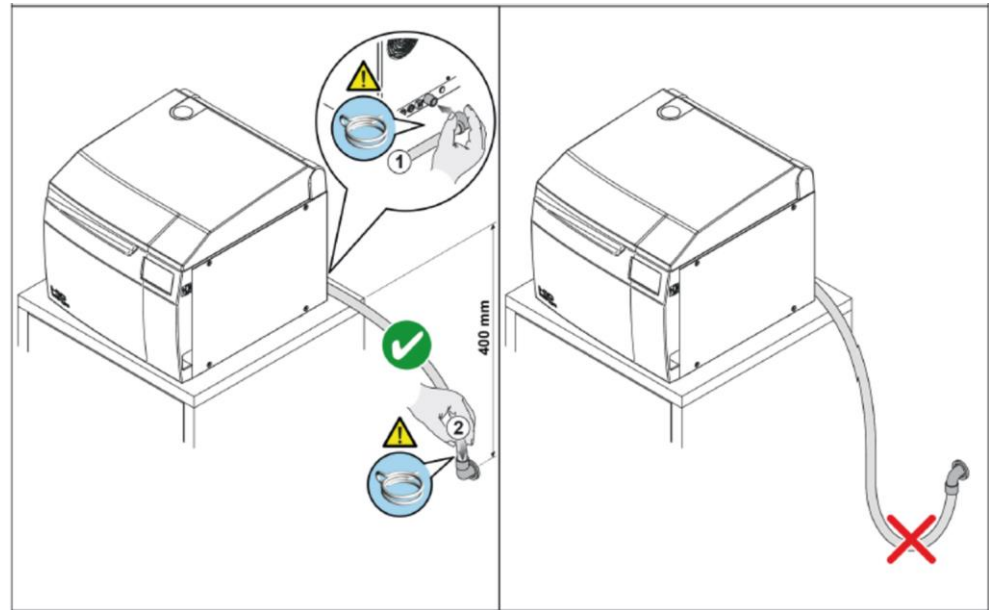

#### **WARNING**



ARRANGE DRAIN PIPE SO AS TO AVOID DEPRESSIONS AND SHARP BENDS TO PREVENT THE SIPHON EFFECT AS WELL AS OPERATING FAILURES.

#### **WARNING**



DRAINAGE MUST BE MADE IN COMPLIANCE WITH THE INTERNATIONAL AND NATIONAL STANDARDS AND UNDER THE EXCLUSIVE RESPONSIBILITY OF THE USER.

#### **WARNING**



IF, WHEN INSTALLING THE DRAIN, THE CONNECTION TO AN EXTERNAL TRAP IS REQUIRED, THE LATTER MUST BE AT LEAST 50MM HIGH AND CAN BE INSPECTED AT THE BOTTOM.

During installation, please observe the following precautions:

- since the temperature of drainage water is 95°C, both drain pipe ends must be fixed to the hose fitting, and duly secured in place with the supplied clamp;
- the end of the drain pipe must be placed at a height that complies with specifications, with respect to the support surface of the device;
- the inner diameter of the fixed drain pipe shall be at least 40 mm;
- extensions of the supplied drain pipe shall not be carried out. Possible extensions may cause drainage problems.

## FIRST START-UP

### DOOR OPENING

To open the thermo-disinfector it is necessary to release the door applying moderate force and take it to the vertical position.

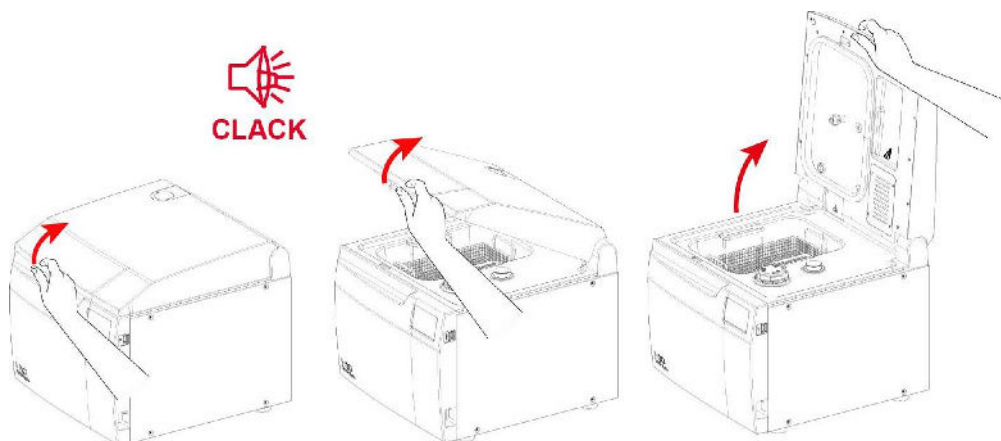

#### **WARNING**

TO PREVENT THE RISK OF FINGER CRUSHING TAKE THE DOOR TO ITS COMPLETE OPENING.

## BASKET EXTRACTION AND INSERTION

Remove the basket by grasping it through the proper handles, as shown in the figure. Once it is refitted inside the chamber, make sure that **both handles are correctly positioned in the proper seats on the chamber surface**.

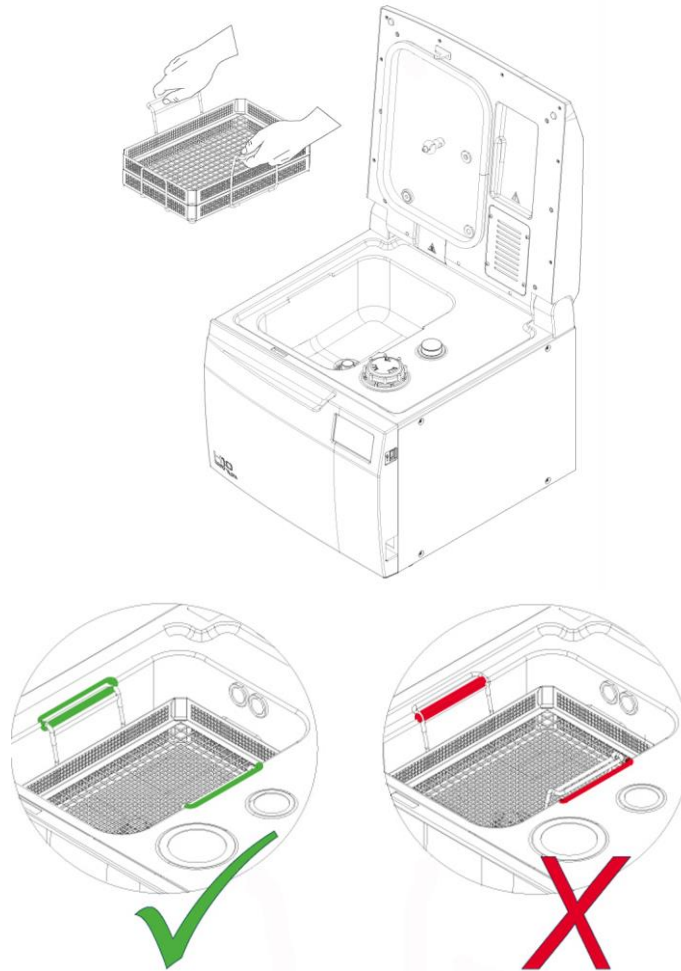

### NOTE

HANDLE WRONG POSITIONING MAY LEAD TO WATER LEAKAGE DURING CYCLES AND THE DEVICE COULD SHOW OPERATING MALFUNCTIONS.

Insert the specific instrument holders inside baskets, as shown in the figure.

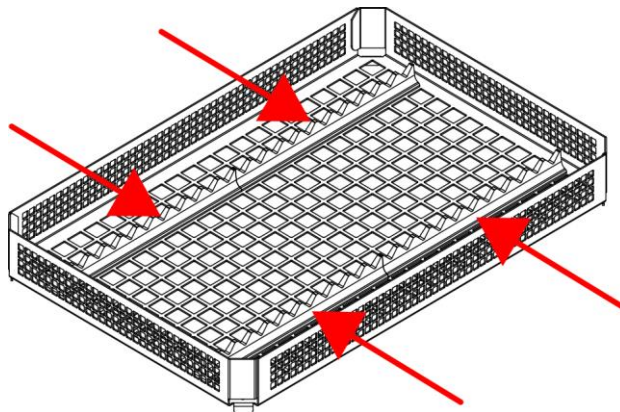

## FILLING OF SALT RESERVOIR

The thermal disinfecter is equipped with an inner salt tank, used for the regeneration of the ion exchange resins contained in the integrated water softening system.

**Upon the first use after installation it is necessary to fill completely the tank with water, then with salt.**

Unscrew the salt tank plug, insert the supplied funnel, fill reservoir with water, and slowly pour the salt up to the appearance of the salt at the plug level. Check that the maximum tank filling level is not exceeded. At the end of the operation, screw the plug in its seat and wait for about 5 minutes until the salt is dissolved.

Some cycles can be carried out with empty salt tank. The number of cycles that can be carried out varies according to the water hardness set (see table in the WATER HARDNESS paragraph).

### WARNING



USE NON-IODISED COARSE SALT OR SALT FOR DISHWASHERS. AT THE END OF THE FILLING OPERATION, RINSE THE SURFACE WITH CLEAN WATER AND REMOVE ALL TRACES OF SALT AND WATER FROM THE SURFACE USING A CLOTH OR ABSORBENT PAPER.

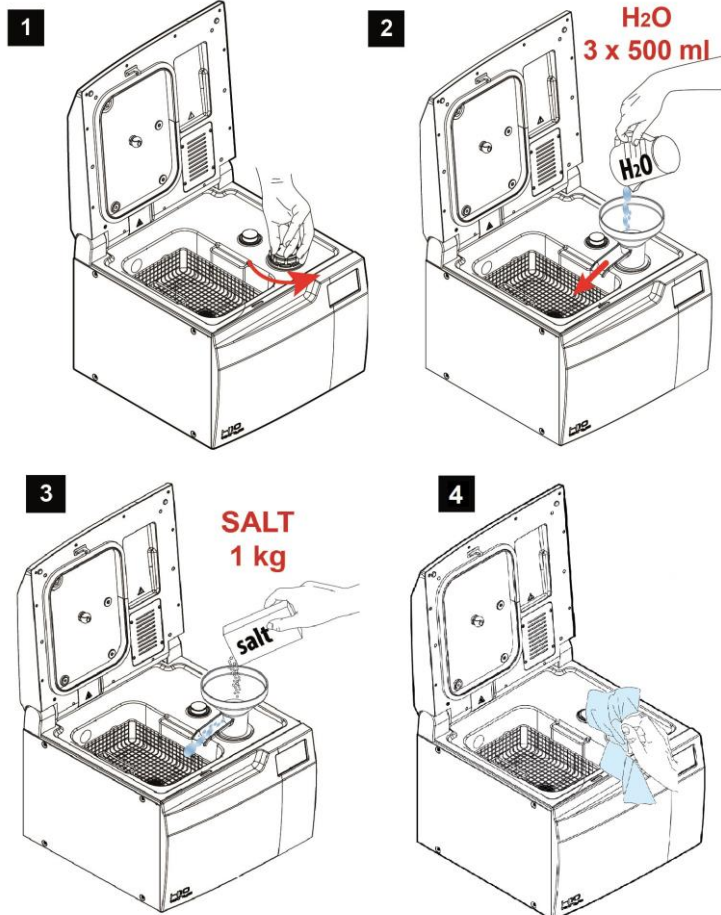

### WARNING



POSITION SALT FILLING FUNNEL SO THAT GUTTER IS FACING INSIDE THE CHAMBER IN ORDER TO PREVENT WATER FROM BEING SPILLED ON THE SURFACE.

## FILLING OF DETERGENT RESERVOIR



The thermo-disinfector is equipped with an inner reservoir for detergent to fill before the use. Remove the reservoir plug and insert the supplied funnel. Fill the supplied container and slowly pour the detergent. Visually check that the maximum reservoir filling level is not exceeded. At the end of the operation refit the detergent reservoir plug.

### **WARNING**



WEAR PROTECTIVE GLOVES AND GOGGLES.  
IF TOO MUCH DETERGENT IS FILLED IN, REMOVE FLUID FROM  
RESERVOIR SURFACE WITH A CLOTH OR ABSORBENT PAPER.

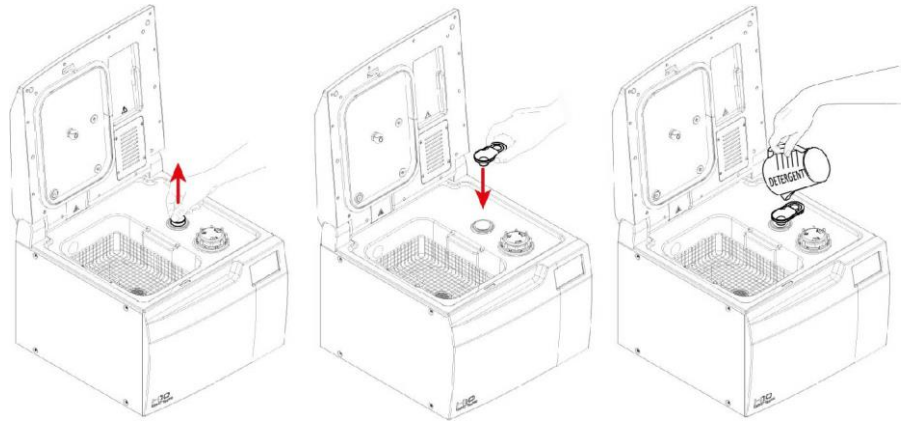

### **NOTE**



AT THE FIRST FILLING IT IS POSSIBLE THAT DETERGENT AUTONOMY  
IS LOWER THAN STANDARD BECAUSE THE SUPPLY CIRCUIT MUST  
BE COMPLETELY FILLED.

## VALIDATED DETERGENTS

We recommend using validated detergents, only.  
To consult the detergent list, refer to the "VALIDATED DETERGENTS" document attached to  
the supplied documentation.

### **NOTE**



THE THERMAL DISINFECTOR IS VALIDATED FOR USE WITH SPECIFIC  
DETERGENTS, SPECIFIED IN THE ATTACHED ADDITIONAL SHEET  
97050820 VALIDATED DETERGENTS.  
THE CHANGE OF DETERGENT, CHOSEN FROM THE VALIDATED ONES,  
MUST BE MADE AFTER THE MINIMUM DETERGENT LEVEL HAS BEEN  
INDICATED ON THE SCREEN. WE RECOMMEND USING VALIDATED  
DETERGENTS, ONLY.

### NOTE

FOLLOW THE INSTRUCTIONS FOR USE OF THE DETERGENTS INDICATED IN THIS MANUAL.

THE EFFECTIVENESS OF THE WASHING AND THERMAL DISINFECTION HAS BEEN TESTED IN ACCORDANCE WITH THE APPLICABLE STANDARDS USING THE VALIDATED WASHING AGENTS ACCORDING TO PRECISE PARAMETERS OF DURATION, TEMPERATURE, EXTENSION AND DOSAGE.

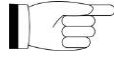

THE USE OF DETERGENTS OTHER THAN THOSE VALIDATED BY THE MANUFACTURER OR A USE OTHER THAN THE INDICATED ONE CAN CAUSE MALFUNCTIONS AND/OR DAMAGE OF THE DEVICE AND OF THE TREATED MATERIALS.

UNDER THESE CIRCUMSTANCES, WASHING AND THERMAL DISINFECTION EFFECTIVENESS CANNOT BE ENSURED AND A SPECIFIC VALIDATION BY THE USER IS THUS REQUIRED.

IN CASE OF DOUBT CONTACT THE TECHNICAL SERVICE DEPARTMENT (SEE APPENDIX).

### WARNING



DO NOT USE DETERGENTS THAT MAY EMIT TOXIC OR HARMFUL GASES.

DO NOT USE POTENTIALLY EXPLOSIVE OR FLAMMABLE DETERGENTS.

DO NOT MIX DIFFERENT DETERGENTS THAT MAY CREATE UNWANTED AND POTENTIALLY HARMFUL CHEMICAL REACTIONS.

### WARNING



DO NOT USE POWDER DETERGENTS: THIS OPERATION MAY DAMAGE INNER MECHANISMS AND CORRODE SURFACES.

## DOOR CLOSING

### WARNING



TO PREVENT THE RISK OF FINGER CRUSHING TAKE THE DOOR TO ITS COMPLETE CLOSING.

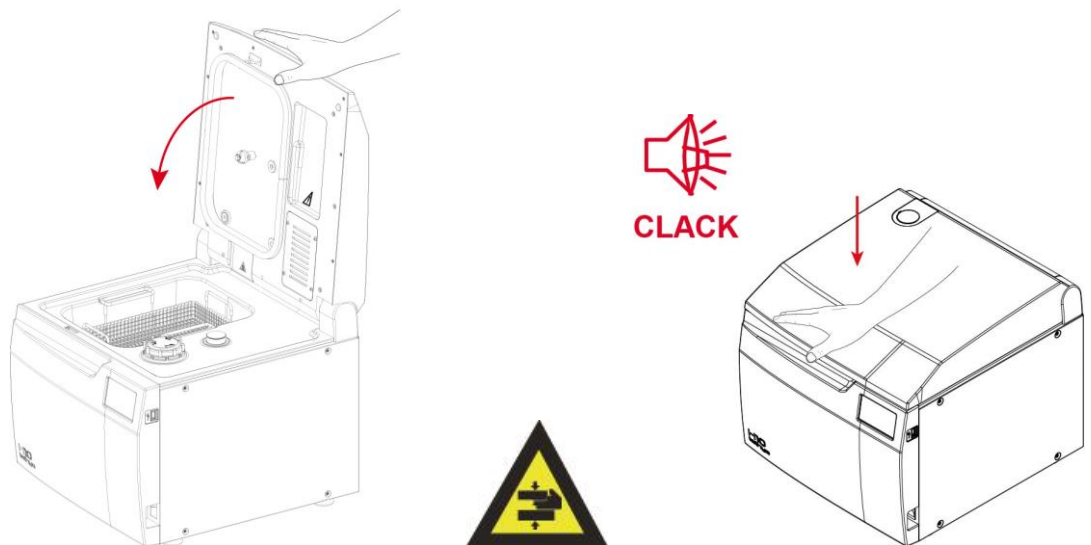

To close the thermo-disinfector press the door with the palm of the hand until the device is closed.

## FIRST START-UP

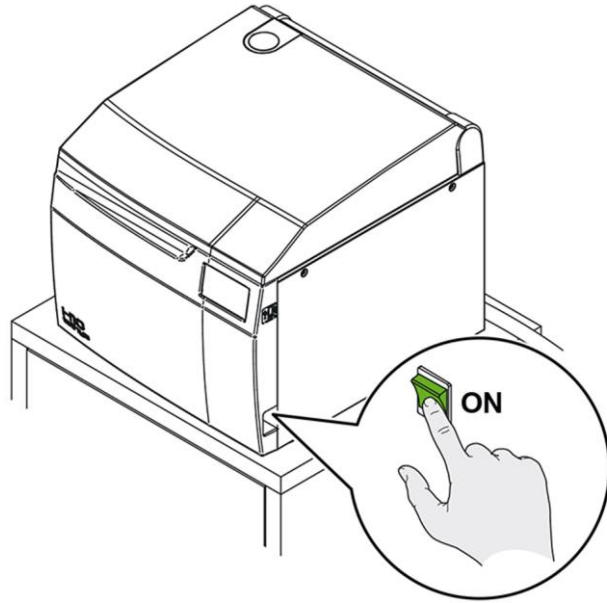

### WARNING

DO NOT TURN ON THE THERMO-DISINFECTOR IF USB STICK IS INSERTED.

## DISPLAYED PROCEDURE UPON FIRST START-UP

At the end of starting procedure the menu for language selection will be displayed. Then select the language and confirm by pressing ENTER:



The menu dedicated to programming the local time and date will then be displayed. Program the local time using the dedicated counters: GMT – hh – mm. Then program the date, using counters: DD – MM – YYYY. Press ENTER to confirm:

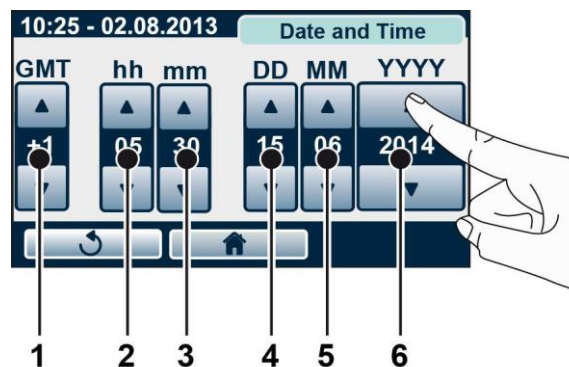

1. time zone
2. hours
3. minutes
4. day
5. month
6. year

After confirming time and date programming, the display shows the menu dedicated to setting the mains water hardness value, expressed in French degrees (°f)

The values are shown according to the following ranges



- < 10°f
- 11-20°f
- 21-30°f
- 31-40°f
- 41-50°f
- 51-54°f

Select the range that includes the previously measured value and press ENTER to confirm

## MAIN MENU

At the end of the start-up procedure the main menu is displayed.

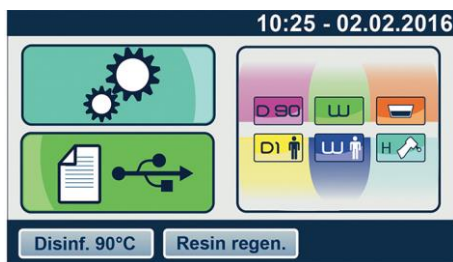

The device waits for the cycle selection.

**WARNING**

IT IS RECOMMENDED TO CARRY OUT A RESIN REGENERATION CYCLE AFTER A PROLONGED PERIOD OF INACTIVITY (E.G. 1 WEEK)

## CONFIGURATION

The **Tethys H10** series offers a wide range of customizable options. The user can thus configure the device according to his/her own needs, adapting the performance based on, for example, the type of activity carried out, the type of material to be washed and disinfected and the frequency of use.

Using the configuration programme, the user can set a series of options available in user-friendly menus.

### NOTE

A CORRECT CUSTOMIZATION OF THE DEVICE PROVIDES THE BEST PERFORMANCE AND THE MOST SATISFACTORY USE.



THE TECHNICAL SERVICE DEPARTMENT (SEE APPENDIX) IS AVAILABLE TO HELP USERS BY PROVIDING SUGGESTIONS OR ADVICE ON THE BEST WAY TO USE THE OPTIONS IN THE SETUP PROGRAMME.

## SETTINGS

To access the configuration programme, press the key indicated in the figure:

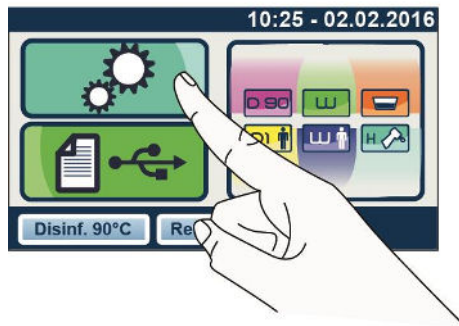

### LANGUAGE



Select the desired language using the scroll arrows.

## DATE AND TIME

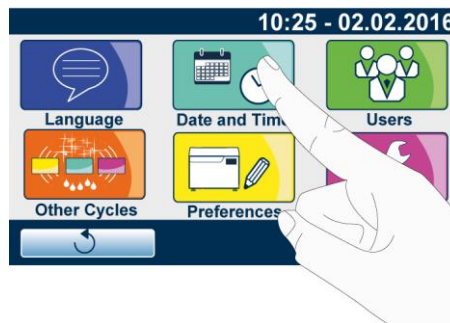

Use the cursors shown in the figure to set date and time.

Press  to confirm the selection.

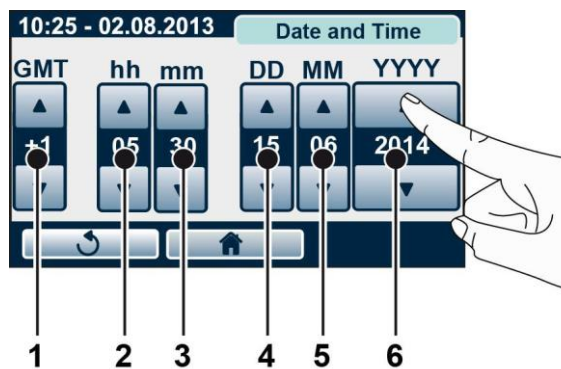

1. time zone
2. hours
3. minutes
4. day
5. month
6. year

## USER



The USER function allows limiting the use of the thermal disinfector to a pre-defined number of users.

The first user defined on the device will be the system administrator. This user will thus be able to define and edit the rights of all the other users working on thermal disinfector.

When using the device for the first time create the ADMIN user (identified by \*) following the indications in the figure below. Fill in the fields inserting ADMIN user name and PIN.

Press  to confirm the selection.



After ADMIN user registration, the following screen is displayed when accessing user management.

Select the user from the list.

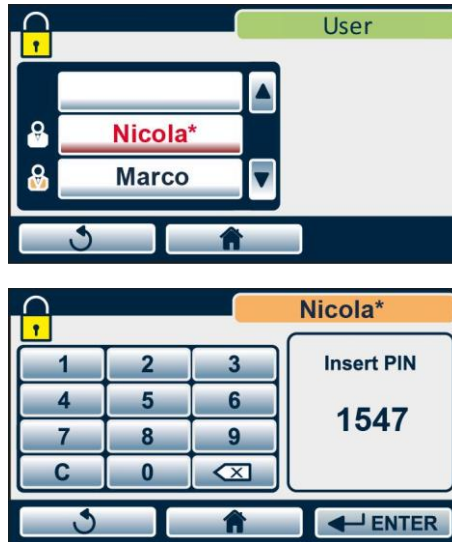

#### NOTE



IF ADMIN USER ENTERS THE PIN INCORRECTLY FOR 3 TIMES, IT IS NECESSARY TO USE THE UNLOCKING PROCEDURE DESCRIBED IN APPENDIX - ADMIN USER PIN RESET.

The ADMIN user can decide whether the device will ask for the generic user PIN upon cycle start (PIN START) and/or upon cycle end (PIN END).

Press ON to activate the PIN request or OFF to deactivate it.

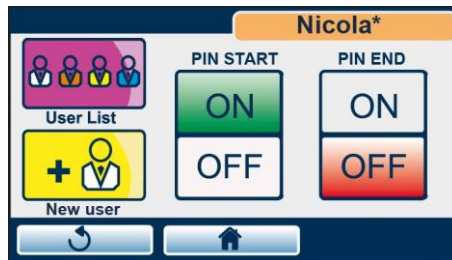

By pressing NEW USER the ADMIN user can create a new generic user, following the instructions described above.

By pressing USER LIST he/she can reach the list of users.



By pressing  key, the data of the highlighted user are displayed:

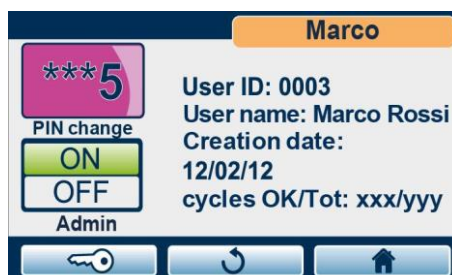

The ADMIN user can change the PIN of the user highlighted in the user list by inserting directly the new PIN or promoting him/her to ADMIN.

By pressing  key, the ADMIN user can delete the highlighted user from the list.



Confirm the deletion by pressing OK or press  key to go back.

By pressing  key the ADMIN user can choose the cycles that the selected user is enabled to perform, by pressing the related icons.



## USER MANAGEMENT

After the registration of the users, the following screen is displayed when accessing user management.

Select your generic user from the list.



Enter the PIN



The generic user can change his/her own PIN, by entering directly the new PIN, he/she can display the cycles he/she is enabled to perform and consult his/her data.



For the generic user (not ADMIN) the list of cycles is in read-only mode.



### OTHER CYCLES

Press "Other Cycles" to select one of the following cycles:

- Resin regeneration
- Ultrasound Test
- Decalcification
- D2 Custom\*

\*for the characteristics of this cycle, refer to the chapter CUSTOM CYCLES.



### RESIN REGENERATION CYCLE

With a frequency programmed based on the set water hardness, the device automatically regenerates resins during the following cycles: "Disinf. 90°C", "Washing", "Handpieces H", "D1 Custom", "D2 Custom" and "W1 Custom".

It is recommended to carry out a "Resin Regeneration" cycle after a prolonged period of inactivity (e.g. 1 week).  
Set the device as explained in FIRST START-UP chapter and press the key shown in the figure.

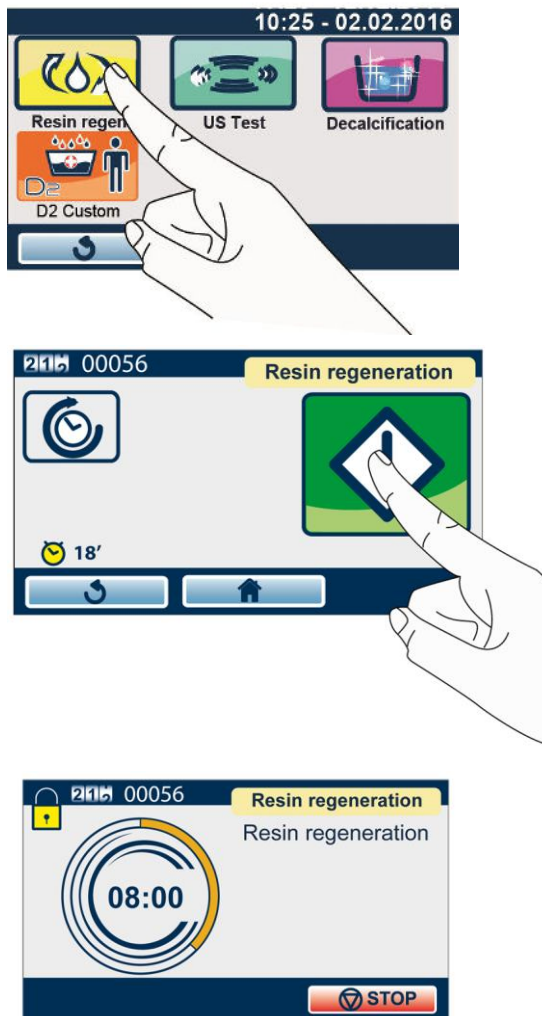

At the end of the regeneration process the following screen appears and the device is ready to be used.

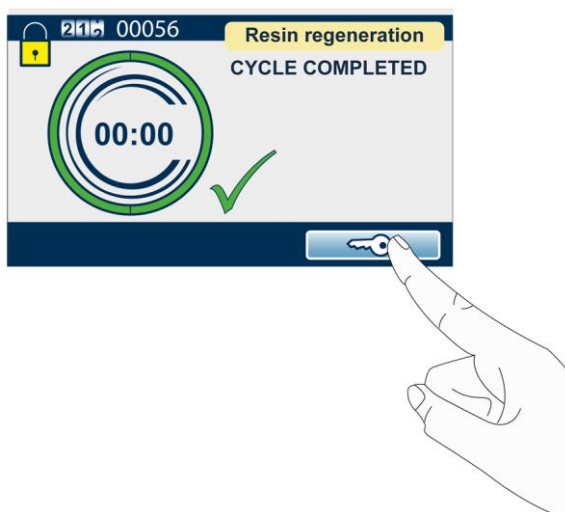



## ULTRASOUND TEST CYCLE

To test ultrasound operation, refer to the technical standard "Australian Standard™ AS 2773.2-1999 Ultrasonic cleaners for health care facilities" PART 2 - SECTION 6 - Point 6.2 - method ii) both for test execution and result.

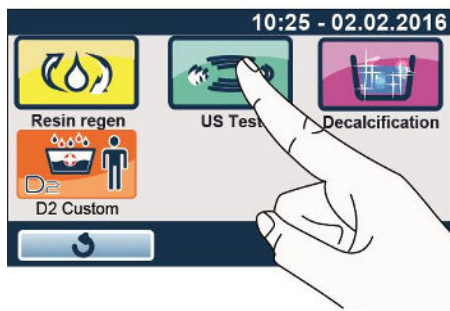
Set the device as explained in the Standard and press the key shown in the Figure.



 **NOTE**  
USE ONE BASKET ONLY.

 **NOTE**  
DO NOT INSERT TESTER NOW, BUT AT A LATER STAGE, WHEN REQUESTED.

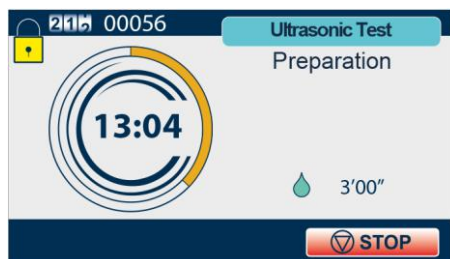
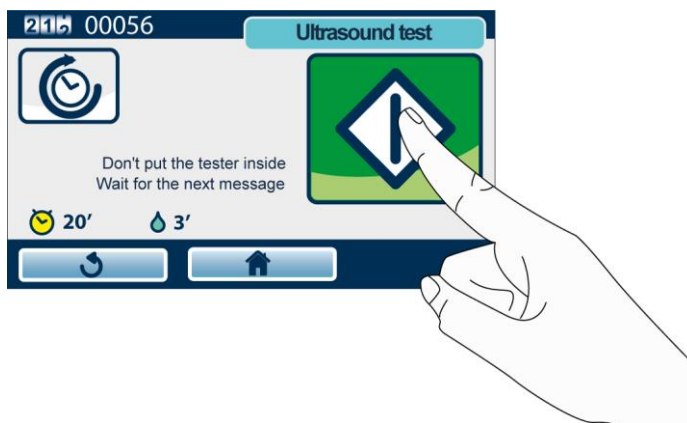

Insert tester in the centre of basket.

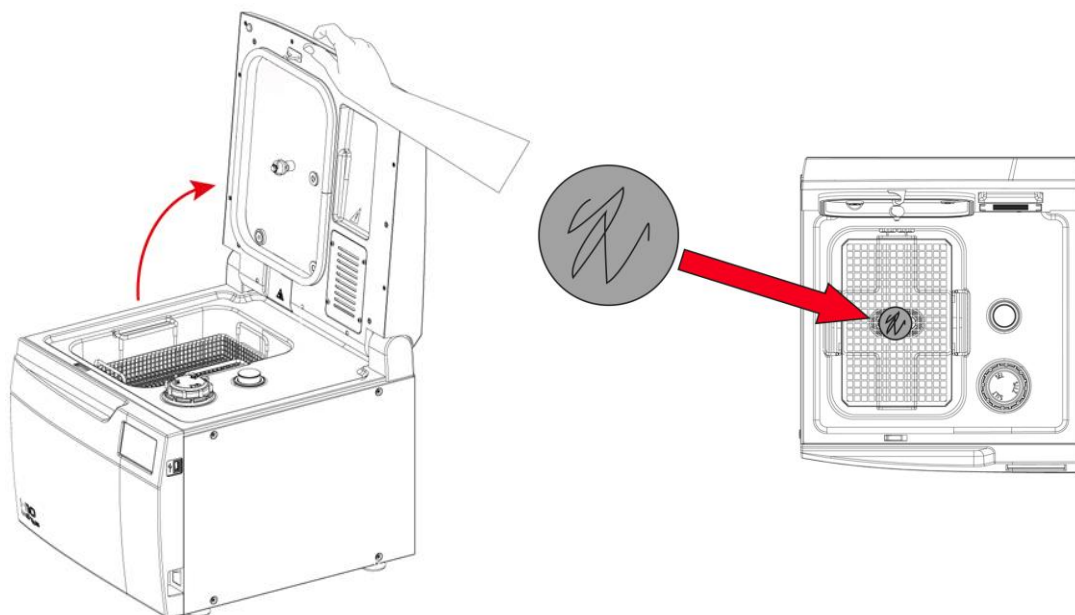
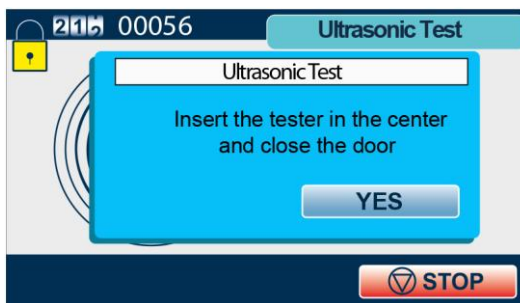

**NOTE**



BEFORE PRESSING "YES", MAKE SURE THAT TESTER HAS BEEN INSERTED IN THE CENTRE OF BASKET AND THAT COVER HAS BEEN CLOSED

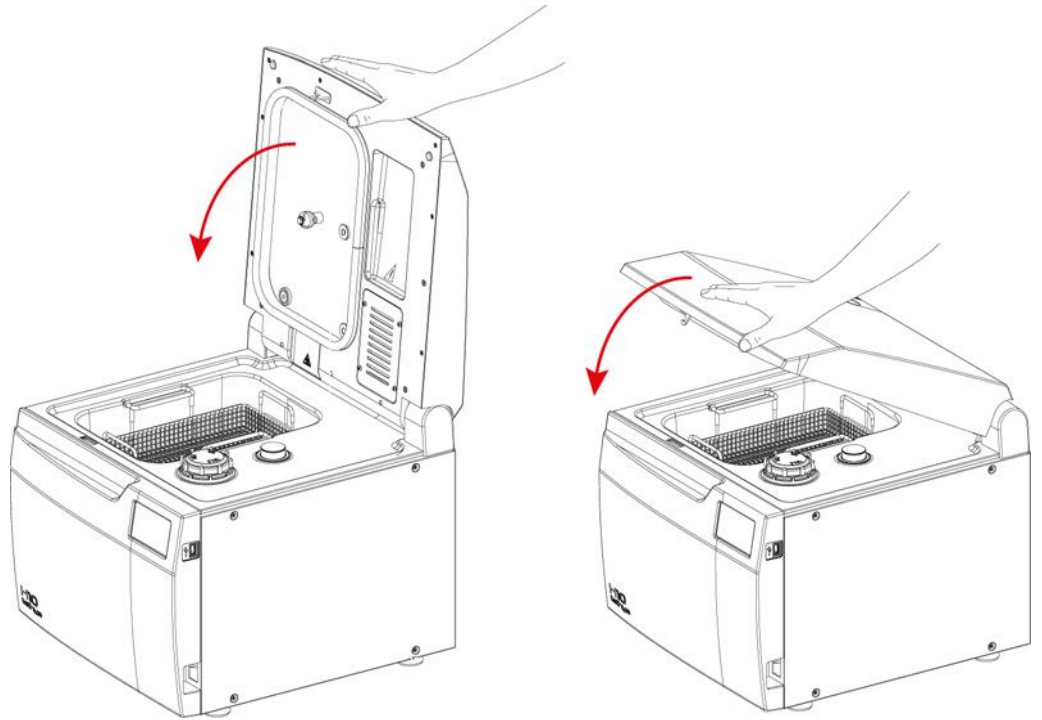

**NOTE**



INSERT THE TESTER WITHIN 20 MINUTES.

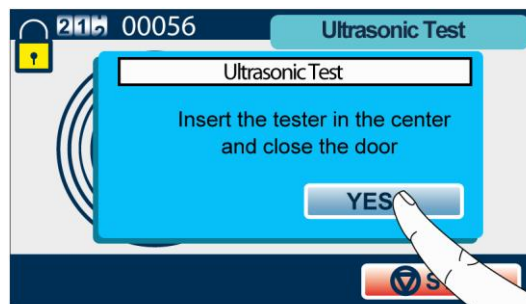

At the end of the ULTRASOUND TEST the following screen appears and the device is ready to be used.



## DECALCIFICATION CYCLE

A white thin layer could deposit on cover and chamber metal surfaces due to a high setting of water hardness value.

Machine can be cleaned running the special "Decalcification" cycle.

**When carrying out this cycle, use a special limescale remover for water cocks and fittings, to be filled in manually. Use only limescale removers for water cocks and fittings based with Sulfamic Acid and/or Citric Acid and/or Phosphoric Acid.**

**WARNING**



AVOID USING TOILET PRODUCTS CONTAINING HYDROCHLORIC ACID OR NITRIC ACID OR SULPHURIC ACID AS THEY COULD DAMAGE THE DEVICE.

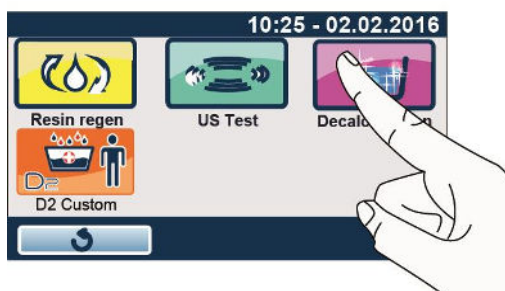

Start the cycle without pouring product inside chamber. **Wait for the next message and pour product in.**



When requested, pour 50 ml of product inside chamber and close cover.

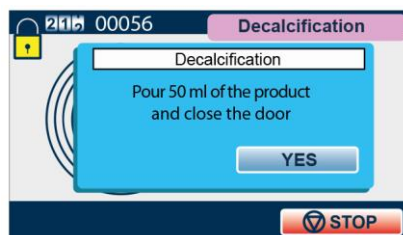

**NOTE**



BEFORE PRESSING "YES", MAKE SURE THAT PRODUCT HAS BEEN Poured INSIDE CHAMBER AND THAT COVER HAS BEEN CLOSED.



## PREFERENCES

Press "PREFERENCES" to set:

- Water hardness
- Unit of measurement
- Screen

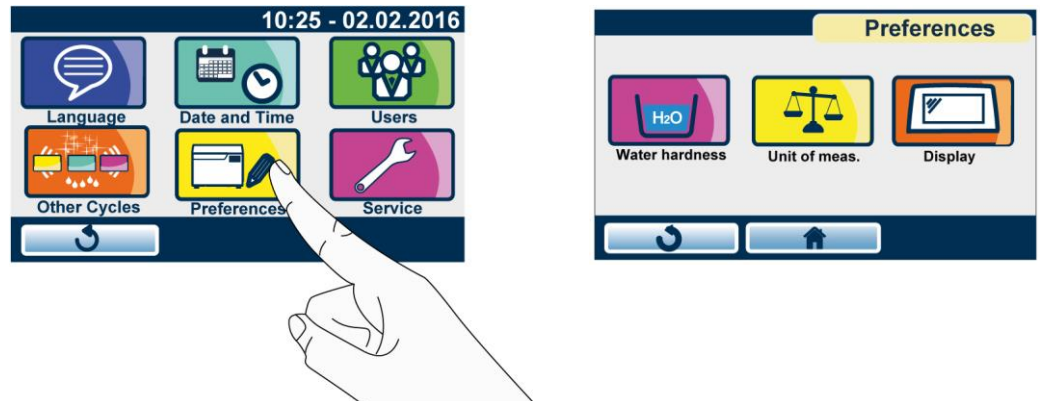

## WATER HARDNESS

The device embeds a softening system allowing reducing mains water hardness.

When the device is started for the first time, user will be prompted to set water hardness value in French degrees (°f). Value can be edited also at a later stage through the "Water hardness" command.

### NOTE



TO KNOW THE HARDNESS VALUE OF YOUR MAINS WATER, CHECK THE VALUE WRITTEN ON THE INVOICE OF YOUR WATER SUPPLY OPERATOR OR CONSULT THE TABLES AVAILABLE ON THE INTERNET.

The softening system carries out resin regeneration using the salt present inside tank.

Regeneration is automatically carried out during the cycle. Regeneration frequency and the number of cycles that can be performed with the salt tank at low level depend on set hardness value.

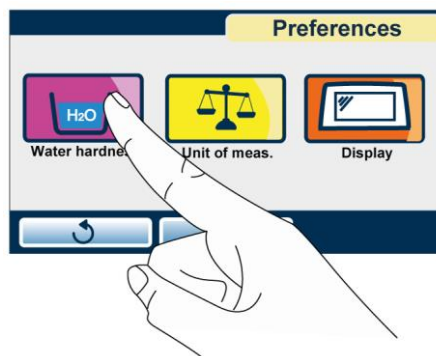

Use the cursors shown in the figure to set water hardness.

Press  to confirm the selection.



The "resin regeneration" (ON/OFF) message signals whether resin regeneration management is active and depends on set hardness value.

The table below compares the hardness values that can be set (in °f) with the regeneration frequency and the number of allowed cycles with salt tank at low level.  
 The factory default value of the device is "21-30" °f

Water hardness (°f)	Enabling of resin regeneration	Regeneration frequency	No. of cycles with empty salt tank
<10	OFF	OFF	OFF
10-20	ON	1 out of 8	7
<b>21-30</b>	<b>ON</b>	<b>1 out of 6</b>	<b>5</b>
31-40	ON	1 out of 4	3
41-50	ON	1 out of 2	2
51-54	ON	1 out of 1	1

**NOTE**

THE CYCLES INTEGRATING RESIN REGENERATION ARE: RESIN REGENERATION (CYCLE OF "OTHER CYCLES" MENU), DISINF. 90°C, WASHING, D1 CUSTOM, D2 CUSTOM AND W1 CUSTOM.

THE START OF CYCLES WITHOUT REGENERATION (PRE-WASHING, ULTRASOUND TEST, DECALCIFICATION) CAN BE INHIBITED IF THE TIME REQUIRED TO CARRY OUT A REGENERATION HAS ELAPSED. IN THIS CASE, THE DEVICE WILL SIGNAL THIS CONDITION BOTH UPON CYCLE START AND WHEN QUITTING THE PREVIOUS CYCLE. IN CASE OF SIGNAL OR BLOCK, A POP-UP WITH THE MESSAGE "START CYCLE WITH REGENERATION" (CODE E071) WILL APPEAR AND ONE OF THE CYCLES LISTED IN ITEM 1 WILL HAVE TO BE STARTED.



REGENERATION FREQUENCY DEPENDS ON THE SET HARDNESS VALUE: IN CASE OF "21-30" HARDNESS, FOR EXAMPLE, REGENERATION IS CARRIED OUT EVERY 6 CYCLES.

A CERTAIN NUMBER OF CYCLES CAN BE STARTED WHEN SALT TANK IS EMPTY. THE ALLOWED NUMBER OF CYCLES DEPENDS ON THE SET HARDNESS VALUE: IN CASE OF "21-30" HARDNESS, FOR EXAMPLE, 5 CYCLES CAN BE RUN WITH THE SALT TANK AT LOW LEVEL.

WITH THE MINIMUM HARDNESS VALUE (<10) RESIN REGENERATION IS DISABLED (OFF).

TO START "RESIN REGENERATION" CYCLE, SALT MUST BE PRESENT INSIDE THE SPECIAL TANK. THIS CONDITION APPLIES TO ANY WATER HARDNESS VALUE, EVEN "<10".

## UNITS OF MEASUREMENT



Use the cursors shown in the figure to set temperature, water level conversion to 'inchH2O', time format (12 or 24 hours) and date.

Press **← ENTER** to confirm the selection.

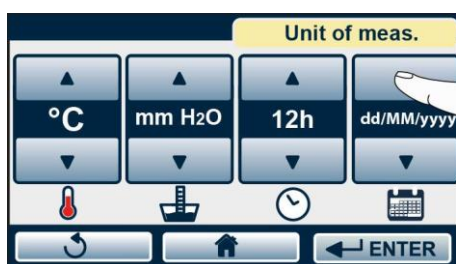

## SCREEN

Use the cursors shown in the figure to set:

- the desired screen brightness
- Screen Saver activation time-out.

Press **← ENTER** to confirm the selection.

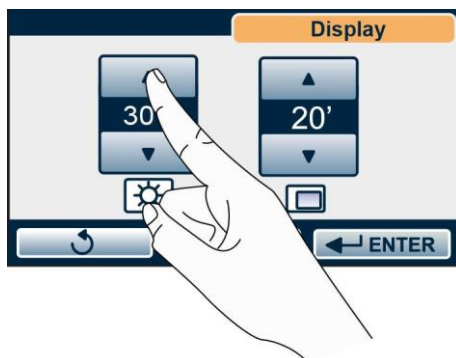
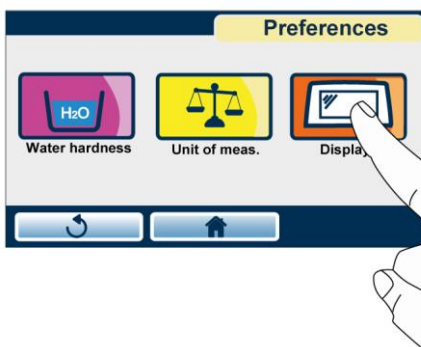

## SERVICE

This menu is intended for the technical service department.

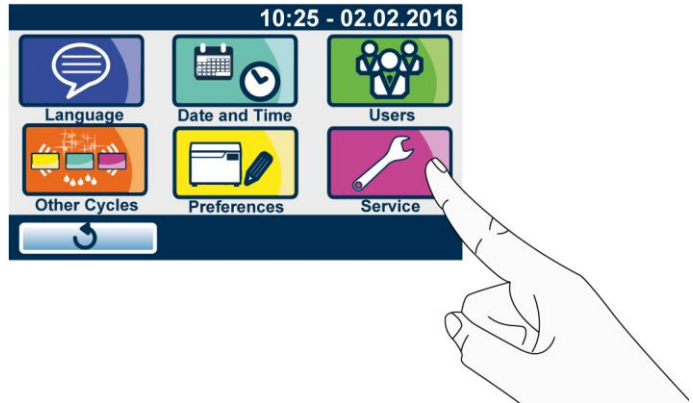

## PREPARATION OF THE MATERIAL



First of all, it should be noted that, when **handling** and **managing** contaminated material, it is a good idea to take the following precautions:

Wear a protective mask and goggles.

Wear anti-cut rubber gloves.

Clean your gloved hands with a germicide detergent.

Always carry the instruments on a tray.

Never carry instruments in your hands;

Protect your hands from contact with any sharp points or edges; this will avoid the risk of contracting a dangerous infection;

After material handling, carefully wash your still gloved hands.

The load to process shall be properly placed in the supplied baskets.

Avoid overloading the instrument baskets.

In order to obtain an effective cleaning, articulated instruments (scissors, pliers, forceps) must be opened, to minimise overlapping surfaces.

Instruments that can be disassembled must be stored according to the indications of the manufacturer. Overlapping shall always be avoided.

Small instruments and objects (whose size is smaller than the basket's mesh) must be inserted in the suitable closed basket.

Floating objects must be inserted in the suitable closed basket or, if their dimensions do not allow that, fixed to the basket through a thin stainless steel wire.



### **WARNING**



AVOID DIRECT AND REPEATED CONTACT WITH DIRTY MATERIALS. ALWAYS USE THE UTMOST CARE; USE ALL THE SUITABLE PERSONAL PROTECTIVE EQUIPMENT, BOTH BEFORE AND AFTER THE TREATMENT.

### **NOTE**



IF THE INSTRUMENTS SHOW TRACES OF PARTICULARLY ADHERENT MATERIALS, SUCH AS CEMENTS OR RESINS, IT IS RECOMMENDED TO PERFORM A QUICK PRE-TREATMENT (BRUSHING) TO PARTIALLY REMOVE THEM AND REDUCE THEIR ADHERENCE TO SURFACES.

### **NOTE**



BEFORE PROCESSING ANY INSTRUMENT IN THE INSTRUMENT WASHER, CHECK IN THE MANUFACTURER'S INSTRUCTIONS THAT THEY ARE SUITABLE TO THE AUTOMATIC TREATMENT IN THE THERMAL DISINFECTOR AND CHECK THEIR COMPATIBILITY WITH THE MAXIMUM WASHING TEMPERATURE AND WITH CHEMICALS USED.

### **WARNING**



REFER TO THE INDICATIONS PROVIDED BY THE MANUFACTURER OF THE INSTRUMENT/MATERIAL TO DISINFECT BEFORE PROCESSING IT IN THE THERMAL DISINFECTOR, CHECKING POSSIBLE INCOMPATIBILITY. STRICTLY FOLLOW THE INSTRUCTIONS FOR USE OF DETERGENTS OR DISINFECTANTS AND THE OPERATOR'S MANUAL OF AUTOMATIC DEVICES FOR WASHING AND/OR LUBRICATION.

To get the best effectiveness of the disinfection process and preserve the material over time, increasing its useful life, follow the instructions below.

- Make sure that all instruments are disinfected in an open position;

- Position cutting instruments, (scissors, scalpels, etc.) so that they can **not** come into contact with each other during disinfection;
- Arrange recipients (cups, bowls, test tubes, etc.) resting on their side, or upended, thus avoiding pooling water;
- Do **not** load trays beyond the limit indicated (see Appendix).

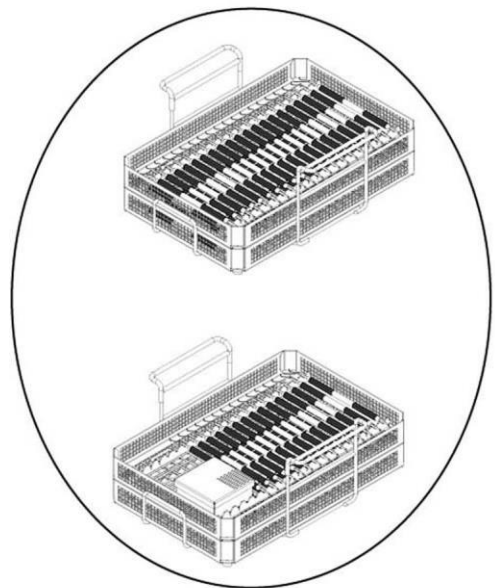
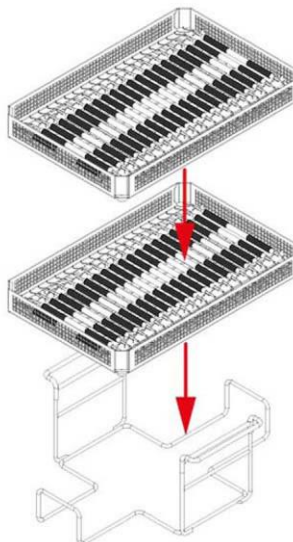
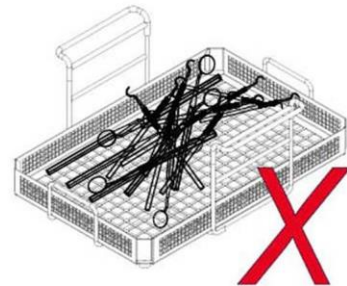
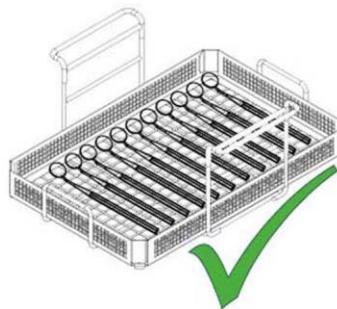
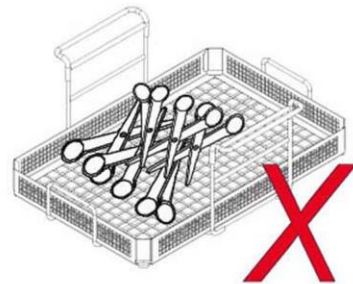
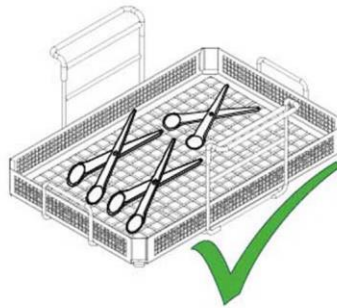
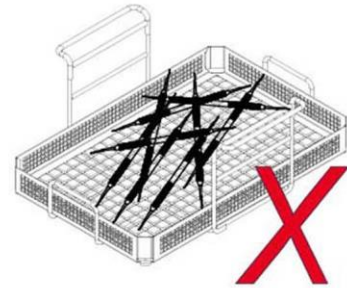
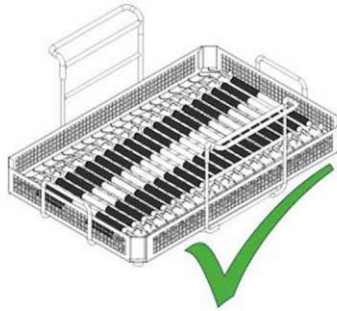

## PREPARING THE MATERIAL FOR HANDPIECES H CYCLE



For general handling methods for instruments, refer to the previous paragraph.

**HANDPIECES H** cycle can be used only with the **HMD accessory for handpieces** and after cycle activation by the Service Centre.



### WARNING

WHEN USING THE ACCESSORY, SELECT ONLY THE SPECIFIC CYCLE FOR THE TREATMENT OF HANDPIECES. OTHER CYCLES MAY DAMAGE HANDPIECES DUE TO THE USE OF ULTRASOUND.

For further information on the **HMD accessory for handpieces**, refer to the relevant manual (code 97055219).

## CYCLES



### WARNING

BEFORE EACH CYCLE CHECK THAT THE ROTARY NOZZLE TURNS AND THAT THERE ARE NO INTERFERENCES WITH THE LOAD INSIDE THE WASHING CHAMBER.  
IF THE ROTATION DOES NOT TAKE PLACE CORRECTLY AND FREELY, CARRY OUT THE NOZZLE MAINTENANCE (SEE MAINTENANCE APPENDIX).

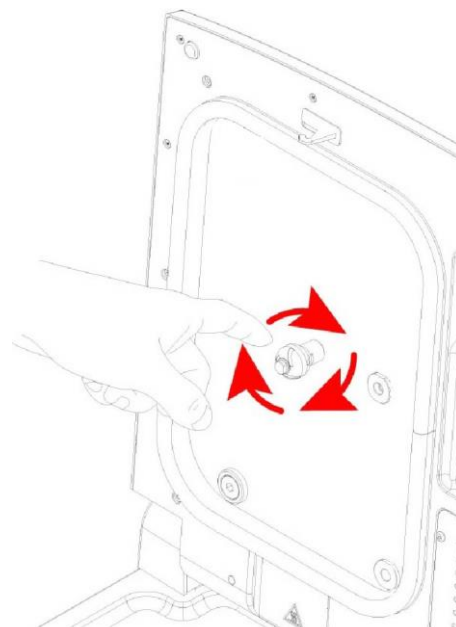
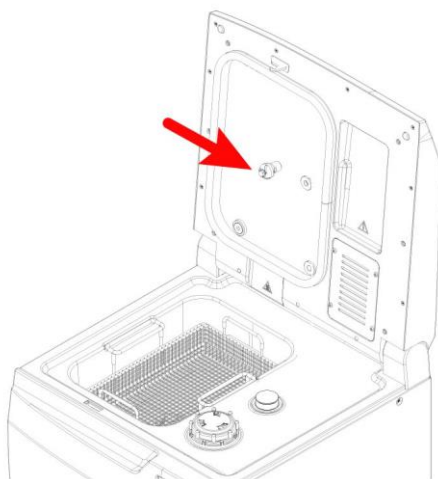

### THERMAL DISINFECTION CYCLE (D90)



The thermal disinfection treatment aims at reducing bioburden (bacteria, viruses, etc.) present on the instruments at the end of their use and allowing their safe handling by health professionals properly equipped with personal protective equipment (PPE).

Thermal disinfection is preceded by a washing phase to eliminate organic and inorganic residues present on the instruments at the end of their use and is followed by a drying phase that eliminates traces of humidity from the load.

The thermal disinfection cycle is suitable for the treatment of the following materials:

- Stainless steel surgical/generic instruments;
- Carbon steel surgical/generic instruments;
- Glass items
- Mineral-based items;
- Heat resistant plastic items;
- Heat resistant rubber items;
- Other generic materials suitable for thermal disinfectant treatment.

Rotary instruments, instruments made of untreated aluminium or with decorative anodising and instruments with ducts or cavities with reduced opening and high depth, are explicitly excluded from use.

Dental mirrors are extremely delicate and their reflective surfaces can deteriorate over time.

### NOTE



THERMAL DISINFECTION IS SUITABLE FOR ALMOST ALL THE MATERIALS AND INSTRUMENTS, PROVIDED THAT THEY CAN BEAR WITHOUT DAMAGE A TEMPERATURE OF 80°C OR 90°C DEPENDING ON THE SELECTED CYCLE (IF THIS IS NOT THE CASE, OTHER LOW-TEMPERATURE DISINFECTION SYSTEMS MUST BE USED).

After having inserted the load in the thermal disinfectant basket (following the precautions indicated in '**Preparing the material**' chapter) select the desired cycle by pressing the button:

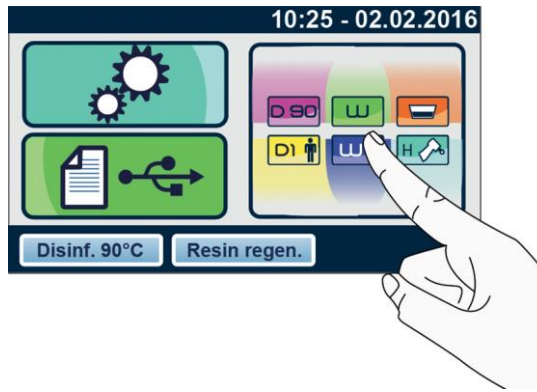

Start the cycle by pressing the key corresponding to THERMAL DISINFECTION. The cycle counter appears in the upper left corner.

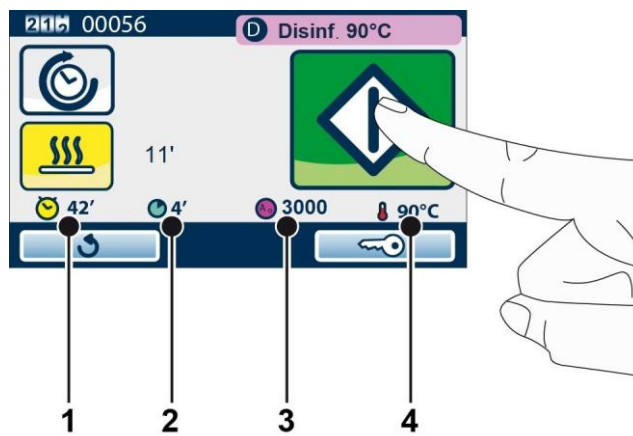

1. total cycle time
2. disinfection time
3. A0 (required for the selected cycle)
4. process rated temperature

#### NOTE

##### A0 THERMAL DISINFECTION PARAMETER

A0 PARAMETER (INTRODUCED BY STANDARD EN 15883) ALLOWS ASSOCIATING A NUMERIC VALUE TO THE THERMAL DISINFECTION LEVEL REACHED.

A0 IS CALCULATED, STARTING FROM THE TEMPERATURE EXCEEDING 65°C, DURING THE HEATING PHASE AND DISPLAYED, STARTING FROM THERMAL DISINFECTION PHASE, IN STEPS OF 50 UNITS.



#### WARNING

AT THE END OF THE CYCLE IT IS **ESSENTIAL** TO VISUALLY INSPECT THE OBJECTS TO CHECK THEIR PROPER WASHING.



## WASHING CYCLE (W)

The washing process aims at eliminating organic and inorganic residues present on the instruments at the end of their use, and is suitable for almost all materials, except for the porous, hygroscopic and water-soluble ones.

Rotary instruments, instruments made of untreated aluminium or with decorative anodising and instruments with ducts or cavities with reduced opening and high depth, are explicitly excluded from use.

The reflective surfaces of dental mirrors can be damaged by ultrasounds.



### **WARNING**

THE LOAD TREATED WITH THIS PROGRAMME IS NOT DISINFECTED. USE THE WASHING PROGRAMME ONLY AS A PREPARATION TO A SUBSEQUENT THERMAL DISINFECTION PROGRAMME OR IF THE LOAD TO TREAT CAN NOT BE TREATED AT LEAST AT 80°C OR FOR MATERIALS NOT CONTAMINATED AND NOT INTENDED TO COME INTO CONTACT WITH PATIENTS. AT THE END OF THIS PROGRAMME, HANDLE THE LOAD WITH CARE, USING THE SUITABLE PERSONAL PROTECTIVE EQUIPMENT.

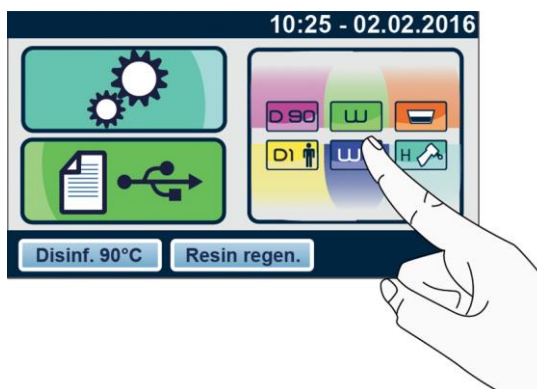

Start the cycle by pressing the button corresponding to WASHING CYCLE.  
The cycle counter appears in the upper left corner.



**WARNING**

 AT THE END OF THE CYCLE IT IS **ESSENTIAL** TO VISUALLY INSPECT THE OBJECTS TO CHECK THEIR PROPER WASHING.

## PRE-WASHING CYCLE

The pre-washing cycle is used to avoid the drying of organic residues on the instruments and facilitate their removal during the following washing or thermal disinfection cycle.

Rotary instruments, instruments made of untreated aluminium or with decorative anodising and instruments with ducts or cavities with reduced opening and high depth, are explicitly excluded from use.



**WARNING**

 THE LOAD TREATED WITH THIS PROGRAMME IS NEITHER DISINFECTED NOR WASHED. USE THIS CYCLE ONLY AS A PREPARATION TO A SUBSEQUENT THERMAL DISINFECTION OR WASHING PROGRAMME. AT THE END OF THIS PROGRAMME, HANDLE THE LOAD WITH CARE, USING THE SUITABLE PERSONAL PROTECTIVE EQUIPMENT.

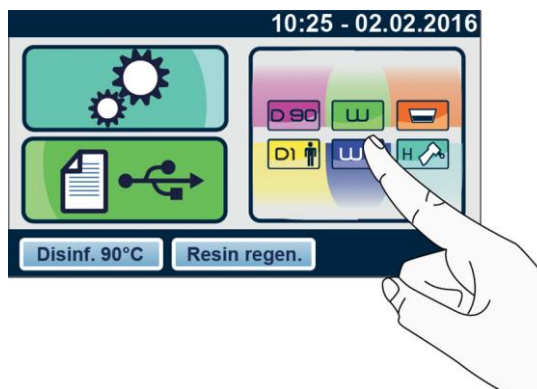

Start the cycle by pressing the button corresponding to PRE-WASHING CYCLE.  
The cycle counter appears in the upper left corner.



## CUSTOM CYCLES

### THERMAL DISINFECTION CYCLES SET BY THE USER (D1 CUSTOM, D2 CUSTOM)



In addition to preset programmes (**90° DISINFECTION**, **WASHING** and **PRE-WASHING**) that can not be modified by the user, customizable programmes are available.

**D1 CUSTOM** and **D2 CUSTOM** are **DISINFECTION** programmes that can be set according to the needs of the user.

**W CUSTOM** is a **WASHING** programme that can be set according to the needs of the user.

In user-defined thermal disinfection cycles, the cycle can be customised by setting washing temperature, A0 value, washing duration and drying duration.

It is possible to set A0 to a value lower than the default one (3000), while remaining within the limits of the prevailing standards.

Washing temperature can be set to 80°C or 90°C.

The duration of the thermal disinfection cycle at 80°C with high A0 values increases by 10/15 minutes compared to the D90 standard cycle.

To set the parameters, select the key shown:



Hold down the key shown to access settings

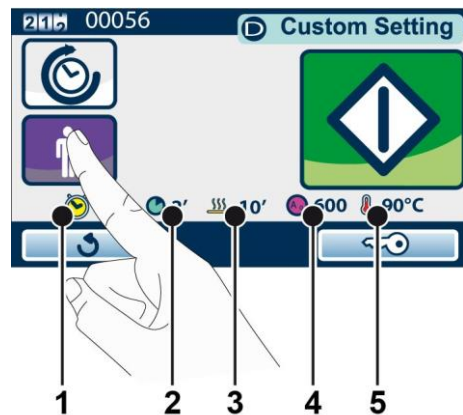

>3 s

1. Cycle total time
2. Disinfection time
3. Drying time
4. A0 value
5. Set temperature

For cycle correct setting, set thermal disinfection temperature (80°C or 90°C), A0 value, washing time and drying time.

A0 parameter can be set between 600 and 6000 with increments of 600, with thermal disinfection set at 90°C.

If thermal disinfection at 80°C is selected, A0 parameter can be set between 600 and 1200, in steps of 300.

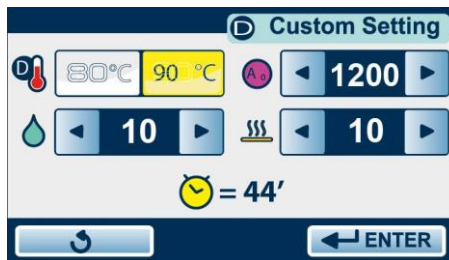

After all these selections, the estimated total time appears.

Use  key to save settings and go back to the previous screen.

Press START key to start the user-defined cycle.

#### **NOTE**



THE SET A0 VALUE CORRESPONDS TO THE MINIMUM VALUE ENSURED FOR EACH DISINFECTION PROGRAMME. ONCE CYCLE IS COMPLETED, THE REACHED AND DISPLAYED A0 VALUE WILL BE HIGHER THAN THE ONE SHOWN UPON CYCLE START.

#### **NOTE**



THE SETTINGS USED ARE STORED FOR A POSSIBLE FOLLOWING USE OF THE CUSTOM CYCLE.

#### **WARNING**



AT THE END OF THE CYCLE IT IS **ESSENTIAL** TO VISUALLY INSPECT THE OBJECTS TO CHECK THEIR PROPER WASHING.

## WASHING CYCLE DEFINED BY THE USER (W1 CUSTOM)



In the user-defined washing cycle it is possible to set the duration (time) of the washing cycle among the selectable options.

**WARNING**

**THE LOAD TREATED WITH THIS PROGRAMME IS NOT DISINFECTED.** USE THIS CYCLE ONLY AS A PREPARATION TO A SUBSEQUENT THERMAL DISINFECTION PROGRAMME OR IF THE LOAD TO TREAT CAN NOT BE TREATED AT LEAST AT 80°C OR FOR MATERIALS NOT CONTAMINATED AND NOT INTENDED TO COME INTO CONTACT WITH PATIENTS.

AT THE END OF THIS PROGRAMME, HANDLE THE LOAD WITH CARE, USING THE SUITABLE PERSONAL PROTECTIVE EQUIPMENT.

To set the parameters, select the key shown:



Hold down the key shown to access settings

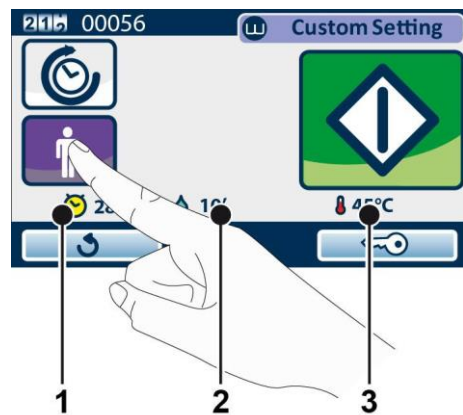

>3 s

1. Cycle total time
2. Washing time
3. Set temperature

Select washing time and drying time

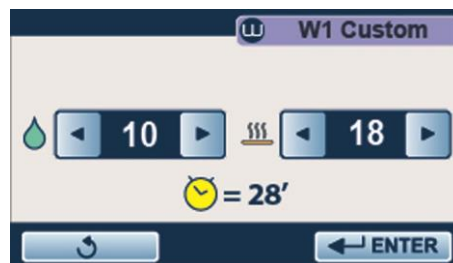

After all these selections, the estimated total time appears.

Use **←ENTER** key to save settings and go back to the previous screen.

Press START key to start the user-defined cycle.

## HANDPIECES THERMAL DISINFECTION CYCLE (HANDPIECES H)



### WARNING

AT THE END OF THE CYCLE IT IS **ESSENTIAL** TO VISUALLY INSPECT THE OBJECTS TO CHECK THEIR PROPER WASHING.



### WARNING

HANDPIECES H CAN BE USED ONLY WITH THE HMD ACCESSORY FOR HANDPIECES AND AFTER CYCLE ACTIVATION BY THE SERVICE CENTRE.

The thermal disinfection treatment aims at reducing bioburden (bacteria, viruses, etc.) present on the instruments at the end of their use and allowing their safe handling by health professionals properly equipped with personal protective equipment (PPE).

This cycle consists of non-ultrasonic washing and disinfection of the external surfaces of rotary instruments and **must be used** in combination with the special HMD accessory, unless such instruments are explicitly designated as not suitable for thermal disinfection and washing by the manufacturer.

Thermal disinfection is preceded by a washing phase to eliminate organic and inorganic residues present on the instruments at the end of their use and is followed by a drying phase that eliminates traces of humidity from the load.

The HANDPIECES H cycle is suitable for the treatment of the following materials:

- Micromotor handpieces (contra-angle, straight);
- Turbines;
- Scaler tips.



### NOTE

THERMAL DISINFECTION IS SUITABLE FOR ALMOST ALL THE MATERIALS AND INSTRUMENTS, PROVIDED THAT THEY CAN BEAR WITHOUT DAMAGE A TEMPERATURE OF 80°C OR 90°C DEPENDING ON THE SELECTED CYCLE (IF THIS IS NOT THE CASE, OTHER LOW-TEMPERATURE DISINFECTION SYSTEMS MUST BE USED).

Prepare the load on the HMD accessory (taking the precautions indicated in the chapter “**PREPARING THE MATERIAL FOR HANDPIECES H CYCLE**”). Position the accessory inside the thermal disinfectant (1), close the upper door (2), select and start the specific cycle for the treatment of handpieces (3).

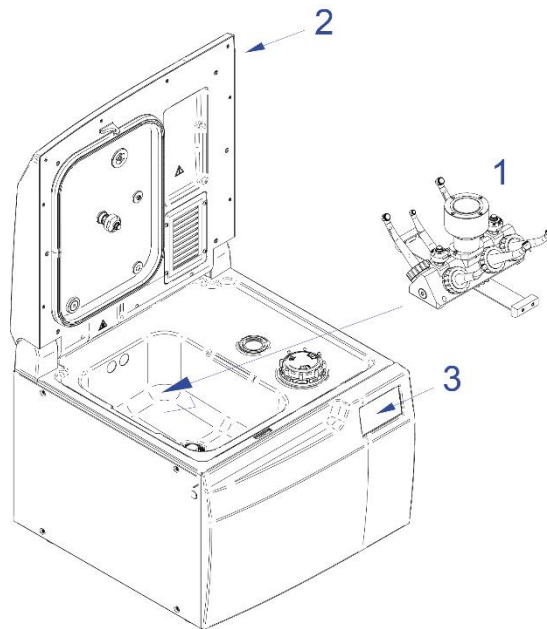

Access the CYCLE SELECTION menu:

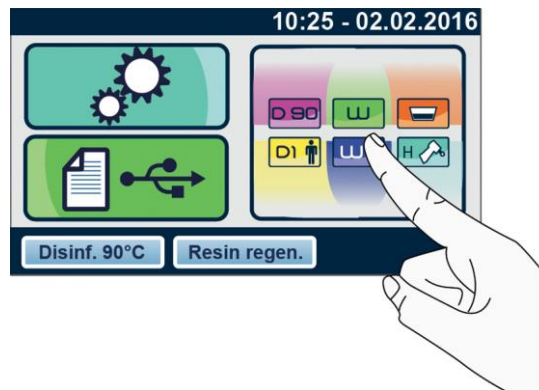

Select the HANDPIECES H cycle:



Make sure that the accessory is correctly positioned and confirm with ENTER:



Start the HANDPIECES H cycle:

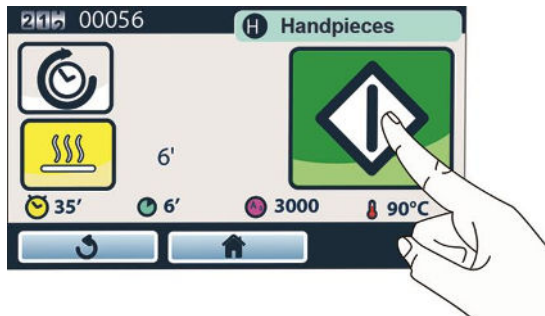

At the end of the cycle, remove the thermal disinfectant (1) and slide the handpieces out of their seats (2):

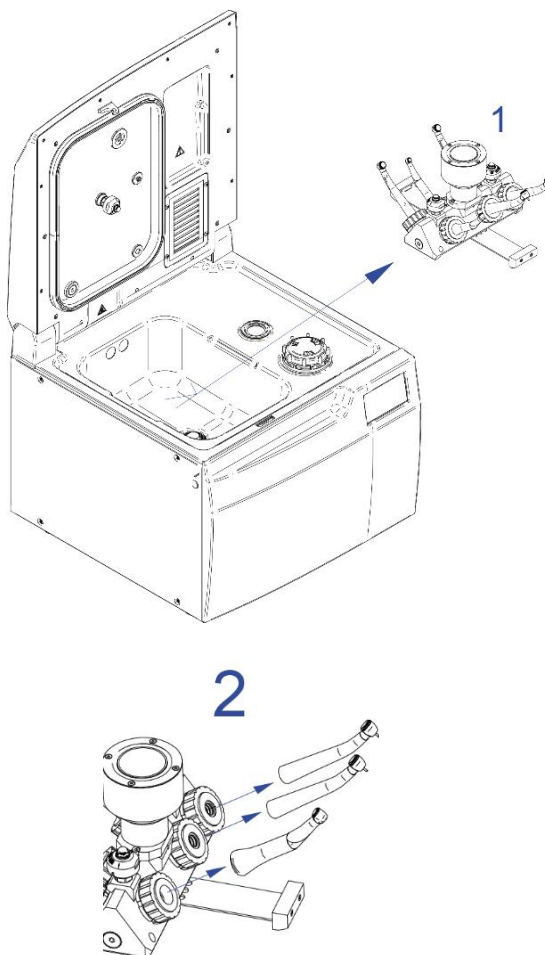

**NOTE**

**A0 THERMAL DISINFECTATION PARAMETER**

A0 PARAMETER (INTRODUCED BY STANDARD EN 15883) ALLOWS ASSOCIATING A NUMERIC VALUE TO THE THERMAL DISINFECTATION LEVEL REACHED.

A0 IS CALCULATED, STARTING FROM THE TEMPERATURE EXCEEDING 65°C, DURING THE HEATING PHASE AND DISPLAYED, STARTING FROM THERMAL DISINFECTATION PHASE, IN STEPS OF 50 UNITS.

**WARNING**

AT THE END OF THE CYCLE IT IS **ESSENTIAL** TO VISUALLY INSPECT THE OBJECTS TO CHECK THEIR PROPER WASHING.

**WARNING**



THE INTERNAL WASHING AND DISINFECTION CYCLE SHOULD NOT BE CONSIDERED COMPLETED IF, AT THE END OF SUCH CYCLE, THE TREATED HANDPIECE IS FOUND OUT OF ITS SEAT.

**WARNING**



THE METAL SURFACES OF THE ACCESSORY AND HANDPIECES REACH HIGH TEMPERATURES AT THE END OF THE CYCLE. USE GLOVES OR APPROPRIATE PROTECTIONS TO HANDLE THEM.

## DRYING FUNCTION

A function allowing adjusting the drying time of each cycle is available.

### NOTE



"STANDARD" DRYING ALLOWS REMOVING WATER RESIDUES FROM A COMPLETE LOAD OF METAL INSTRUMENTS.  
**TO OBTAIN THE BEST DRYING PERFORMANCE, IT IS RECOMMENDED TO SET A LONGER TIME DEPENDING ON THE TYPE OF LOAD.**

After selecting the desired cycle, hold the following key pressed to set the drying time:

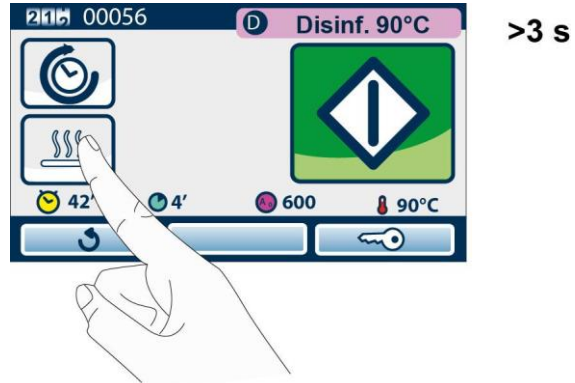

Set total drying minutes of the process. The minimum value that can be set is the standard value for the selected process; if 0 (zero) value is set, the drying phase will be deactivated.

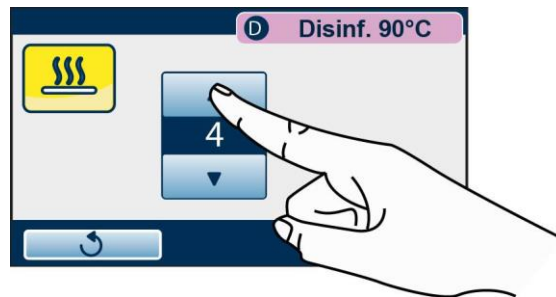

The selected value appears near the key.  
Press "Enter" to confirm the set value.  
Activate the cycle.

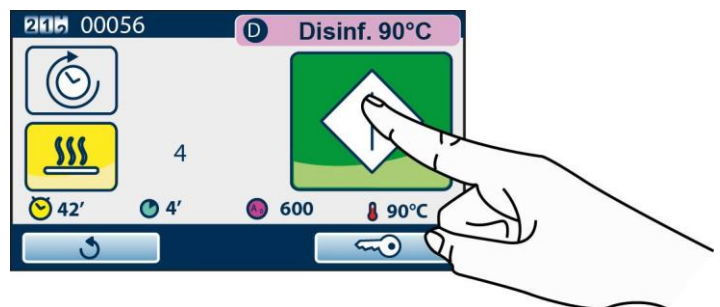

### NOTE



THE VALUE REMAINS STORED SO, IF UPON NEXT CYCLE RUN YOU DO NOT WISH TO ACTIVATE DRYING, SHORTLY PRESS THE DRYING ICON

## DELAYED START FUNCTION

A function to set cycle delayed start is available.  
After selecting the desired cycle, hold the following key pressed to set the delay time:

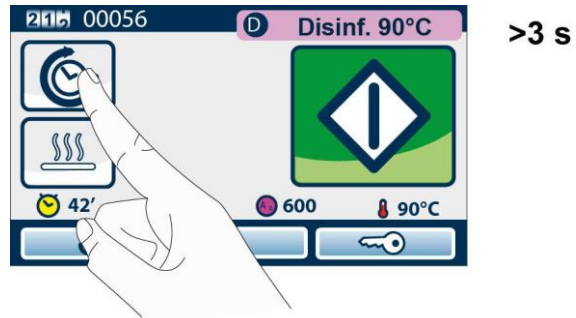

Set start delay time. The minimum value that can be set is 30 minutes. Cycle start time is displayed close to command. Press "Enter" to confirm setting.

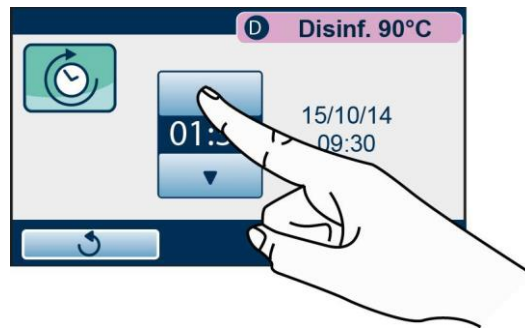

Cycle start time will be displayed close to button.  
Activate the cycle.

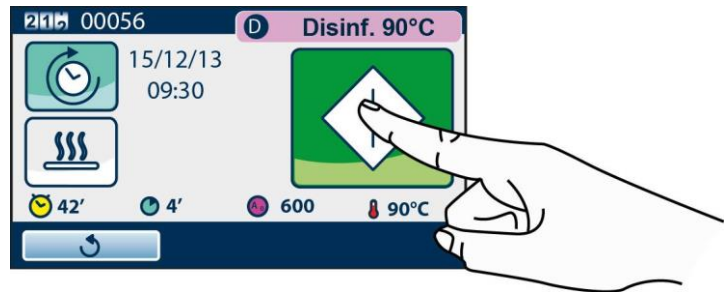

### NOTE



THE TIME REMAIN STORED. AT THE FOLLOWING PROGRAMME EXECUTION, SHORTLY PRESS  KEY TO ACTIVATE THE OPTION USING THE PREVIOUSLY SET VALUE.

## EXECUTION OF THE CYCLE

As an example, the execution of the **Thermal disinfection (D90)** cycle includes the following phases:

- Pre-washing
- Washing
- 3 Rinses
- Heating
- Thermal disinfection (starting when thermal disinfection temperature is reached and ending with draining).
- Drying:

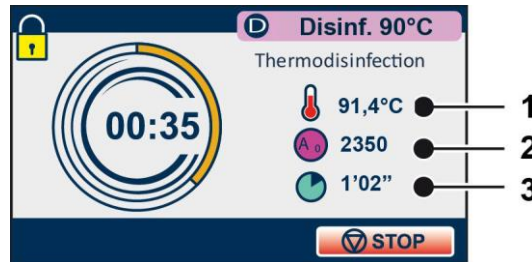

1. Temperature in the chamber
2. A0
3. Disinfection time (fixed until the thermal disinfection starts, then decreasing until it ends)

The **Handpieces H** cycle, instead, includes the following phases:

- Washing without ultrasound
- One rinse
- Heating
- Thermal disinfection (starting when thermal disinfection temperature is reached and ending with draining)
- Drying.

The **Pre-washing** cycle features only the Pre-washing phase.

## CYCLE OUTCOME

At the end of the cycle it is important to check the process outcome.

If message **"CYCLE COMPLETED"** is displayed, this means that the cycle ended correctly without interruptions due to any alarms, and the material disinfection is ensured.



If the cycle **FAILED** it did NOT end correctly and the code of the alarm that interrupted the cycle appears. Refer to 'Alarms' appendix.



### NOTE



AT THE END OF THE CYCLE, IF THE DOOR IS NOT OPENED, AN ACTIVE VENTILATION PHASE OF THE WASHING CHAMBER IS ENABLED TO REMOVE HUMIDITY RESIDUES FROM THE LOAD. SUCH FUNCTION AUTOMATICALLY ENDS AFTER ABOUT 2 HOURS OR WHEN THE DOOR IS OPENED.

## DOOR OPENING AT THE END OF THE CYCLE

At the end of the cycle, in case of successful outcome, it is necessary to release the door locking mechanism by pressing the key shown in the figure, to allow door opening.

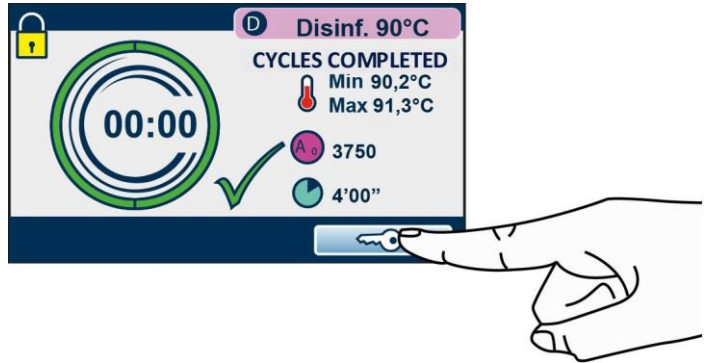

### WARNING



AT THE END OF THE CYCLE IT IS **ESSENTIAL** TO VISUALLY INSPECT THE OBJECTS TO CHECK THEIR PROPER WASHING.

## MANUAL INTERRUPTION

The cycle can be interrupted by the operator in any moment, by holding down the key indicated in the figure for about three seconds.



The command generates **E999 error** since the cycle could not end correctly.

### NOTE



FOR THE COMPLETE DESCRIPTION OF THE ALARMS REFER TO 'ALARMS' APPENDIX.

### WARNING



AFTER A MANUAL INTERRUPTION OF THE PROGRAMME THE LOAD MUST BE HANDLED WITH CARE SINCE THE DISINFECTION IS NOT ENSURED.

## DATA MANAGEMENT

To access DATA MANAGEMENT section press the relevant icon.

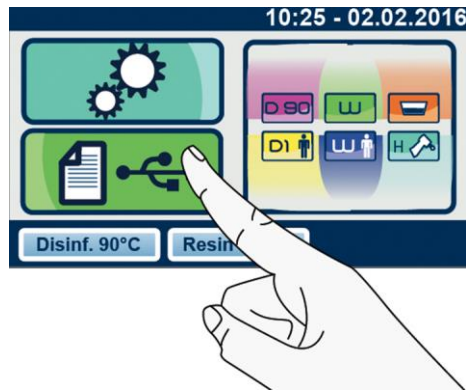

### SYSTEM INFORMATION

By selecting SYSTEM INFO all the information about the thermal disinfector settings are displayed.

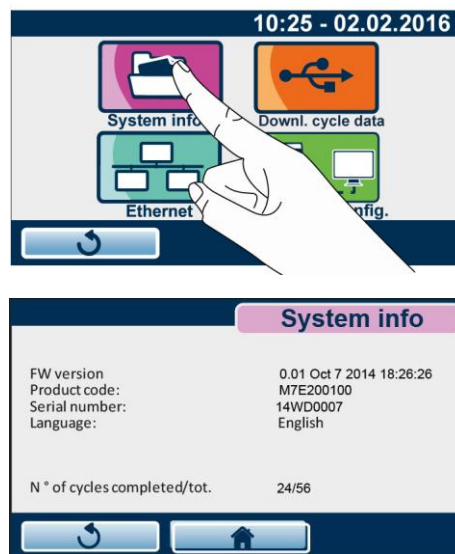

### DOWN. CYCLE DATA

It is possible to copy data about the cycles carried out, stored in the inner memory of the thermal disinfector, on a USB stick.

To download cycle files, select the following key:

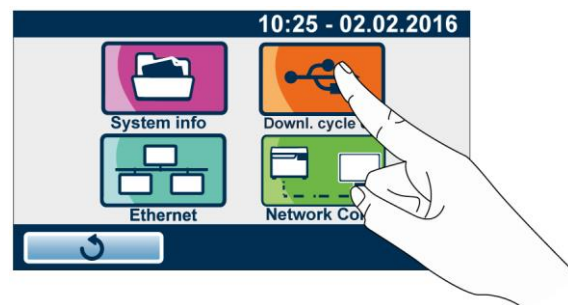

#### NOTE



THE USB FLASH DRIVE MUST BE FORMATTED ACCORDING TO THE INSTRUCTIONS SET FORTH IN THE APPENDIX - TECHNICAL CHARACTERISTICS SUMMARY TABLE.

**Before carrying out the following operations insert the USB key.**  
 If the USB flash drive is not present, its insertion is required.

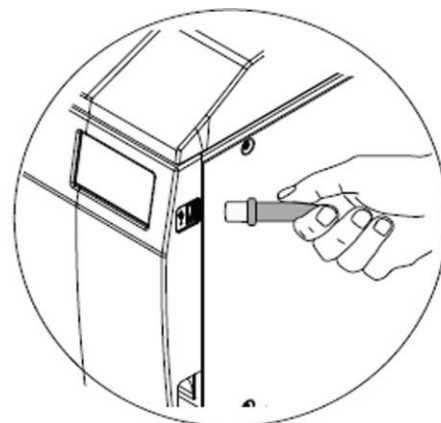

It is possible to select the number of cycles to download on the external storage device. The available selections are "New", "Last 10", "Last 50", "Last 100" or "Custom Mode". If you choose the Custom Mode option, set the cycle interval you want to download.

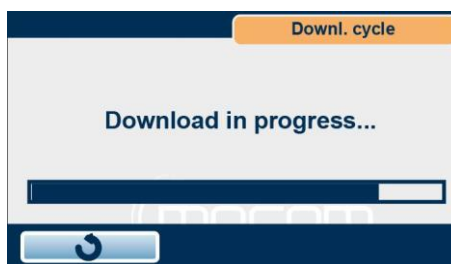

**NOTE**

 CYCLE REPORT FILES ARE IN PDF FORMAT.

**NOTE**

 WHEN A PRESET VALUE IS EXCEEDED, THE SYSTEM GENERATES A NOTICE ABOUT THE NEED TO CARRY OUT THE DOWNLOAD OF THE DATA CONTAINED IN THE INTERNAL MEMORY. THE NOTICE CAN BE TO RESET BY CARRYING OUT THE DOWNLOAD IN 'DOWNLOAD NEW CYCLES' MODE.

**WARNING**

 DO NOT TURN ON THE THERMAL DISINFECTOR IF THE USB FLASH DRIVE IS INSERTED.

## ETHERNET

The thermal disinfectant can be connected to an Ethernet local network through the proper connector placed at the back of the machine.

Using a web browser (such as Internet Explorer, Chrome, Firefox, etc.) from a PC or another device connected to the local network (tablet, smartphone, etc.) it is possible, by entering the TCP-IP number assigned to the machine, to query the latter to check its operating state. From the web page of the machine it is also possible to download the reports of the cycles performed, to consult or store them.

The thermal disinfectant supports the DHCP protocol.

DHCP (Dynamic Host Configuration Protocol) is a TCP-IP protocol that allows a device to communicate with a specific server and automatically receive the configuration data required to communicate correctly on the network.

Very often, in small networks, the DHCP Server functionalities are integrated in the Internet network router.

For the proper configuration of the thermal disinfectant the three use scenarios are:

- 1) Connection to a local network equipped with DHCP server, with the thermal disinfectant in automatic configuration.
- 2) Connection to a local network equipped with DHCP server, with the thermal disinfectant configured with static IP.
- 3) Direct connection with Ethernet cable between thermal disinfectant and PC.

## LOCAL ETHERNET NETWORK CONFIGURATIONS

To set parameters select the following item:

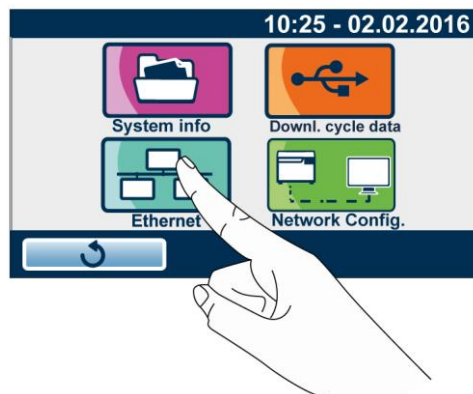

### 1) CONNECTION TO A LOCAL NETWORK EQUIPPED WITH DHCP SERVER WITH THERMAL DISINFECTANT IN AUTOMATIC CONFIGURATION

Connect the thermal disinfectant to the Ethernet local network through a network cable.

In network config. screen a specific number for TPC port to communicate with the thermal disinfectant can be selected; the default value is 10080.



Display the Ethernet configuration page:

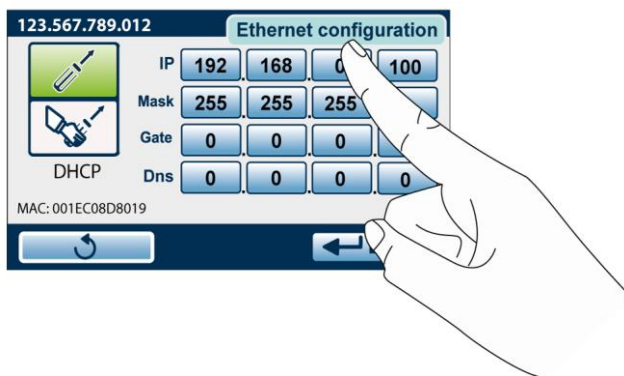

Make sure that Automatic DHCP configuration is selected

With this selection all the numeric fields present on the screen are disabled (they get grey). With this setting, at each start the machine requests the network DHCP server its own configuration using the DHCP protocol.

According to DHCP server configuration the numbering received may change at each start. The TCP-IP number assigned to the machine appears on the upper light blue bar in the first screen (Home).

Type in the number present on the device followed by "." and by the TPC port number (default 10080) in the web browser address toolbar of your PC e.g.: 10.20.8.115:10080:



The programme will display the web page:

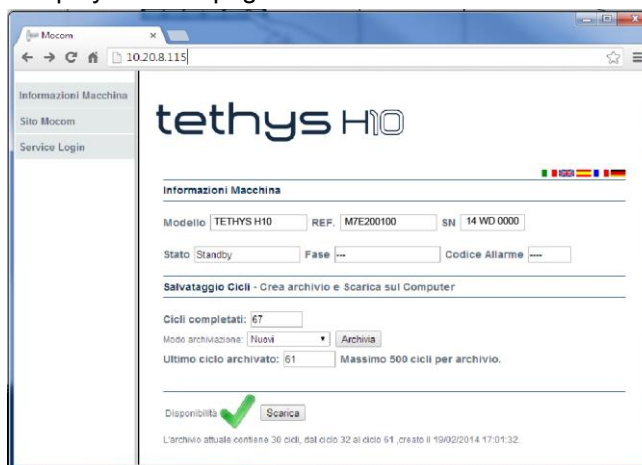

(in the example the URL is http://10.20.8.115:10080)

It is usually possible to set DHCP server in order to always assign the same IP number to a given device or to assign the same number to a given device for a predetermined period of time. For these settings refer to the instruction manuals of your DHCP Server or of the local network Internet router.

For these settings it is necessary to know the 'MAC Address' of the thermal disinfectant that appears in the lower left corner of the Ethernet configuration screen.



## 2) CONNECTION TO A LOCAL NETWORK EQUIPPED WITH DHCP SERVER, WITH THERMAL DISINFECTOR CONFIGURED WITH STATIC IP.

In order to avoid checking often the TCP-IP number assigned dynamically from a DHCP Server, it is possible to assign manually a fixed number of the dynamic numbering of the local network.

To avoid conflicts it is essential to:

- configure the DHCP Server so that it does not assign the selected number to other devices.

Or

- statically assign a number out of the range assigned by the DHCP server to the thermal disinfectant.

For the information needed for a correct configuration check DHCP server settings of the local network.

To statically assign an IP address to the thermal disinfectant:

Access 'Data management' menu.

Display the Ethernet configuration page

Make sure that Automatic DHCP configuration is selected.

With this selection all the numeric fields on the screen are disabled (they get grey).

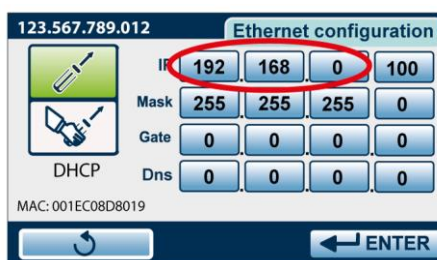

Take the first three numbers of the local network numbering, in the example above the first three numbers are:

**192.168.0**

### **NOTE**



AS AN ALTERNATIVE, IN WINDOWS SYSTEMS IT IS POSSIBLE TO USE THE IPCONFIG COMMAND FROM A 'COMMAND PROMPT' WINDOW (ACCESSIBLE FROM PROGRAMMES -> ACCESSORIES) TO DETECT THE LOCAL NETWORK CONFIGURATION.

Now it is necessary to set statically the new number as follows:



- 1) Select manual configuration
- 2) Set the first three fields of the address with the values detected (e.g.: 192.168.0).
- 3) Assign the chosen number to the last value, e.g. 222 (out of the range assigned automatically, avoiding 0 and 255).
- 4) Check that the Subnet Mask field is set to 255.255.255.0.
- 5) The Gateway address is not important for communications inside the network (set 0.0.0.0).

Then the complete IP address (in this example) is: 192.168.0.100.

To connect to the thermal disinfectant, enter the new number in the web browser address toolbar as shown above (<http://192.168.0.100>).

The programme will display the thermal disinfectant web page.

### 3) DIRECT CONNECTION WITH CABLE BETWEEN THERMAL DISINFECTOR AND PC

It is possible to connect a PC (e.g. a notebook) and a thermal disinfector directly through a network cable, without having to connect them both to a local network.

To obtain the connection, PC and thermal disinfector have to be configured in static mode, as shown in the previous example, taking care that the two devices have the first three fields with the same numbering (e.g. PC 192.168.1.10 thermal disinfector 192.168.1.100).

Access 'Data management' menu. Display the Ethernet configuration page

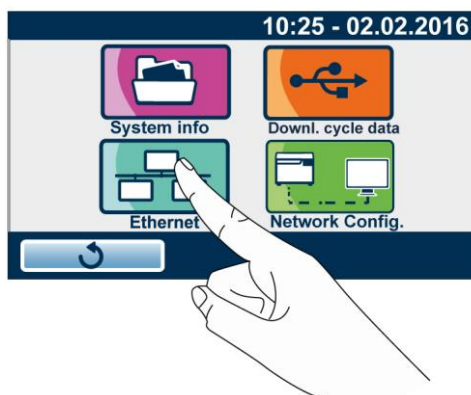

Then make sure that manual configuration  is selected.

The thermal disinfector proposes its default IP Address, i.e. 192.168.1.100. Do not use 0 or 255 for the last address field.

Set the PC as per the following image:

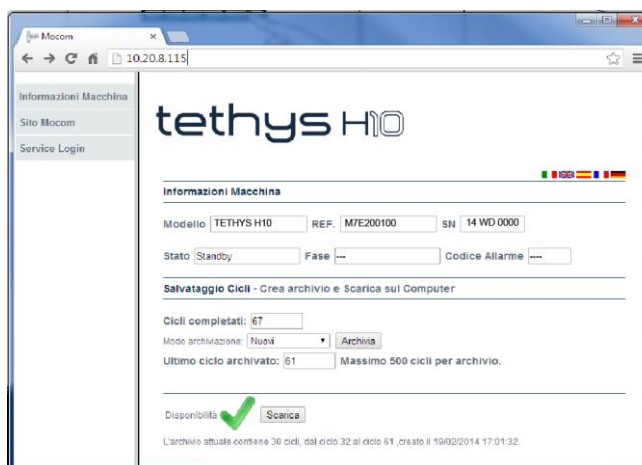
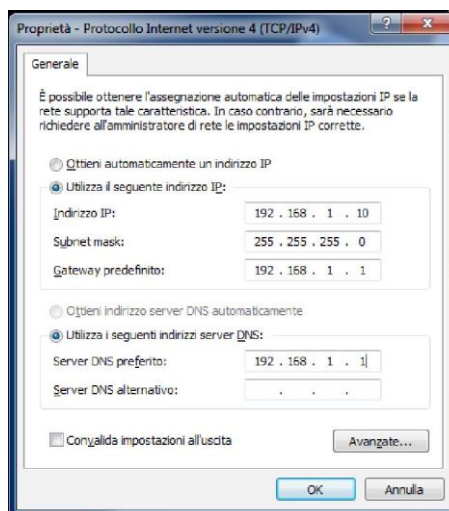

**APPENDIX -  
TECHNICAL  
CHARACTERISTICS  
SUMMARY TABLE**

Device	THERMAL DISINFECTOR Tethys H10
Class (according to Directive 93/42/EEC and subsequent amendments)	IIb
Manufacturer	CEFLA s.c. Via Selice Prov.le 23/a 40026 Imola BO - Italy
Input voltage	220-240V 50Hz 220-240V 60Hz 120V 60Hz
Network fuses (6.3 x 32 mm)	F1: F15A 250V 6.3x32mm (mains supply) F2: F15A 250V (mains supply) F3: T5A 250V (water recirculation pump)
Electronic board fuse 97668148	220-240V F1: T3.15A (5x20 mm) 120V F2: T3.15A (5x20 mm)
Electronic board fuse 97668145	F1: F5A 250V (5x20 mm)
Nominal power	220-240V 50Hz - 2300W 220-240V 60Hz - 2300W 120V 60Hz - 1440W
Rated current	220-240V 50Hz - 10A 220-240V 60Hz - 10A 120V 60Hz - 12A
Insulation class	Class I
Installation category	Cat. II
Operational environment	Indoor use HUMID LOCATION (EN 61010 extended environmental conditions)
Maximum noise level	< 79 dB
Average noise level	70 dB
Ultrasonic pressure	90 dB
Environmental operating conditions	Ambient temperature: between 5°C and 40°C Max relative humidity: 80 % non-condensing up to 31°C. Linear decreasing maximum limit up to 50% at 40°C Altitude: max 1500 m (a.s.l.)
Conditions for storage and transport	Ambient temperature: between 5°C and 40°C Max relative humidity: 80 % non-condensing
External dimensions (HxWxD) (rear connections excluded)	430 x 470 x 500 mm
Net weight	approx. 37 kg
Chamber dimensions (HxWxD)	125 x 224 x 314 mm
Chamber nominal volume	8 litres
Chamber usable volume	6 litres
Basket inner dimensions (HxWxD)	180 x 280 x 30 mm
Detergent tank capacity	0.6 litres (usable volume: 0.5 litres)
Washing and disinfection programs	3 standard programs + 3 programs defined by the user
USB connection	Stick capacity lower than or equal to 2GB: FAT formatting with 16K/sector. Stick capacity higher than 2GB: FAT32 formatting with 16K/sector.
Ethernet connection	RJ45 (max. cable length 29 m)

Water pressure	200 kPa – 500 kPa (2 bar – 5 bar)
Required flow rate (min - max)	2 – 12 litres / min
Mains water hardness (max)	54 °f NOTE: for values higher than 41 °f, it is recommended to use an external softener
Fe2+ / Fe3+ (max)	0.5 ppm
Inlet water temperature	max 30°C
Limits based on water microbial contamination	Minimum microbiological quality required: “drinking water” (Ref. Directive 98/83/EC)
Total maximum heat in watts transmitted to the surrounding air when the WD is activated at an air ambient temperature of (23 ± 2) °C	370 W

## SAFETY DEVICES

The thermo-disinfector is equipped with the following safety devices, for which we provide a brief description of their function:

- **Mains fuses** (see data in summary table)  
User electrical system protection against excessive absorption due to a fault of the device.  
Action: power supply interruption.
- **Electronic circuits protection fuses** (see data in summary table)  
Protection against the excessive absorption due to circuit faults or loads downstream fuses.  
Action: interruption of one or more circuits.
- **Thermal circuit-breakers on mains voltage windings**  
Protection against possible overheating of pump motors or of transformer.  
Action: temporary cut-off (until cooling) of the winding.
- **Safety thermostat with manual reset on heaters**  
Protection against possible component overheating.  
Action: heating resistance power supply interruption.
- **Door locking mechanism safety micro-switch**  
Striker for the correct locking position of door locking system.  
Action: signalling of failed or wrong operation of door locking mechanism.
- **Double temperature sensor of washing chamber**  
Redundant check of disinfection process parameters  
Action: immediate interruption of the programme (in case of malfunction) and generation of alarms.
- **Detergent dosage flowmeter**  
It ensures a proper and repeatable supply of detergent during washing phases.  
Action: immediate interruption of the programme if an unsuitable supply is detected.

**SUMMARY TABLE OF CYCLES**

CYCLE DESCRIPTION	WASHING TEMPERATURE °C	WASHING TIME	ULTRASOUND TIME	DISINFECTION TEMPERATURE °C	A0	DISINFECTION TIME	DRYING TIME	TOTAL CYCLE TIME	MAX TOTAL MASS (kg)
DISINFECTION D90	45	6'	7'	90	3000	4'	0' 6' ÷ 25'	36'	2
WASHING W	45	6'	7'	-	-	-	0' 6' ÷ 25'	20'	
PRE-WASHING	25	5'	-	-	-	-	-	7'	
DISINFECTION D1 CUSTOM	45	6' ÷ 15'	7' ÷ 16'	80 90	600 ÷ 1,200 (at 80°C) 600 ÷ 6,000 (at 90°C)	10'-20' (at 80°C) 1'-9' (at 90°C)	0' 6' ÷ 25'	Depending on the settings	
WASHING W1 CUSTOM	45	6' ÷ 15'	7' ÷ 16'	-	-	-	0' 6' ÷ 25'		
HANDPIECES H (*)	45	6'	-	90	3000	4'	0' 6' ÷ 25'	34'	

(\*) the HANDPIECES H cycle is available only with the HMD accessory; for the activation of the HANDPIECES H cycle contact the Service Centre.

**NOTE**



THE ACCEPTABLE LIMITS FOR PROCESS VARIABLES ARE THOSE PROVIDED FOR BY STANDARDS EN 15883-1 AND EN 15883-2.

**NOTE**



THE INDICATED EXECUTION TIMES REFER TO AVERAGE CONDITIONS. TIMES MAY VARY DEPENDING ON LOAD, MAINS WATER TEMPERATURE AND SETTINGS SELECTED BY THE USER.



**WARNING**



THE DEVICE IS INTENDED ONLY FOR WASHING AND/OR THERMAL DISINFECTION OF RE-USABLE SURGICAL INSTRUMENTS ABLE TO RESIST A TEMPERATURE OF AT LEAST 80°C OR 90°C DEPENDING ON THE SELECTED CYCLE.

IT IS NOT INTENDED FOR THE CLEANING AND THERMAL DISINFECTION OF THERMOLABILE MEDICAL DEVICES.

IT IS NOT INTENDED FOR WASHING INSTRUMENTS HAVING DEEP CAVITIES WITH REDUCED OPENING (SINCE CLEANING AND DISINFECTION OF THE INNER PARTS OF CAVITIES ARE NOT ENSURED).

IT IS NOT INTENDED FOR WASHING ROTARY OR ELECTRONIC INSTRUMENTS, UNLESS EXPLICITLY INDICATED AS SUITABLE BY THE MANUFACTURER

IT IS NOT INTENDED FOR WASHING INSTRUMENTS MADE OF UNTREATED ALUMINIUM OR WITH DECORATIVE ANODISING.

CYCLES	WATER CONSUMPTION DURING CYCLE PHASES			
	PRE-WASHING	WASHING	RINSING	THERMAL DISINFECTION
D90 DISINFECTION	2 lt	6lt	no. 3 x 2 lt	1.5 lt
HANDPIECES H	/	6lt	no. 1 x 2 lt	1.5 lt
WASHING W	2 lt	6lt	no. 3 x 2 lt	/
PRE-WASHING	2 lt	/	/	/

**DISINFECTION**

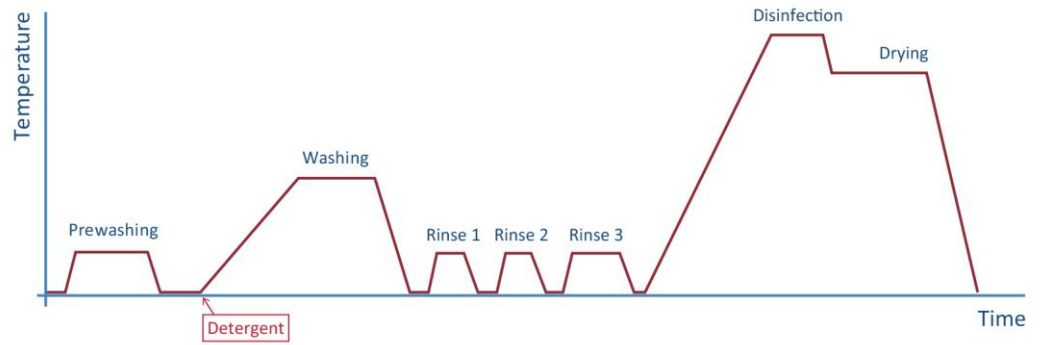

WASHING TIME means the period of time between the reaching of set washing temperature and drainage start.

**WASHING**

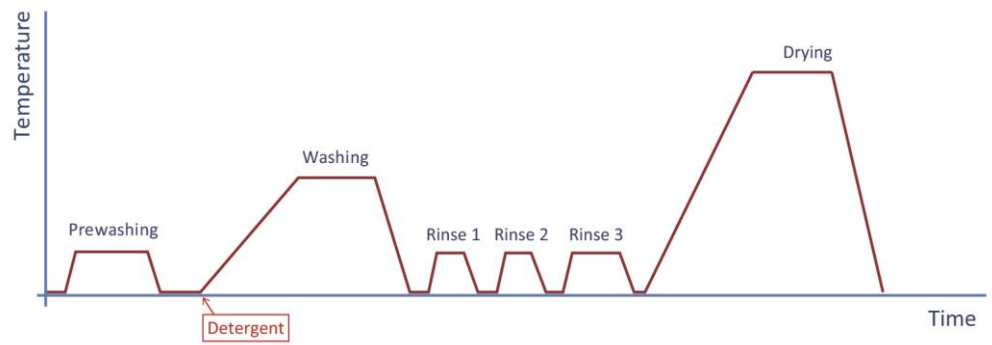

**PRE-WASHING**



**HANDPIECES**

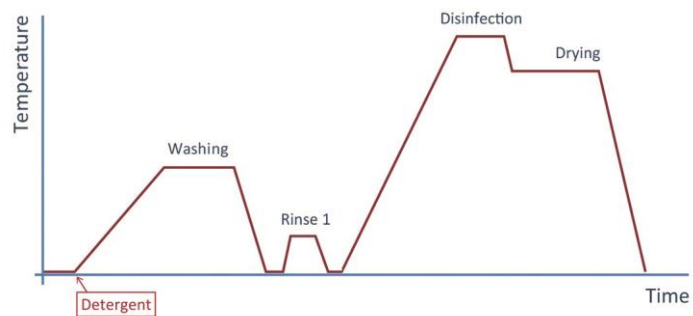

## APPENDIX - MAINTENANCE

### FOREWORD

In addition to correct use, the user needs to perform ordinary maintenance in order to guarantee safe, efficient operation over the device's entire life.

For better quality of maintenance, supplement routine checks with regular periodic check-ups that can be performed by Technical Service Department (*see Appendix*).

It is also fundamental to perform a **periodic thermo-disinfector validation**, i.e. a check of process parameters and their comparison with the reference values.

Refer to 'Thermo-disinfector periodic validation' in the next part of this Appendix.

The ordinary maintenance described below consists in easy manual operations and preventive interventions involving simple instruments.



#### **WARNING**

IN THE EVENT OF REPLACEMENT OF COMPONENTS OR PARTS OF THE DEVICE REQUIRE AND/OR USE ORIGINAL SPARE PARTS ONLY.

### ORDINARY MAINTENANCE PROGRAMME

The table summarizes the maintenance interventions required to maintain the thermo-disinfector in good working order.

In case of **heavy use**, we recommend to **shorten** maintenance intervals:

<b>DAILY</b>	Clean the filter at the bottom of the chamber Clean external surfaces Clean chamber surface from possible residues of detergent Clean residues of water or salt from the surface when filling with salt
<b>WEEKLY</b>	Clean the washing chamber and its accessories Disinfect external surfaces
<b>PERIODIC</b>	See Scheduled Maintenance messages
<b>ANNUALLY</b>	Thermo-disinfector validation ( <i>see dedicated paragraph</i> )

## SCHEDULED MAINTENANCE MESSAGES

The thermal disinfecter periodically displays warning messages relevant to "routine" maintenance operations that must be carried out in order to ensure the proper operation of the device.



Press FATTO to confirm that the required maintenance operation has been completed.

Press REMIND to postpone the operation.

In this case, the warning message will reappear the next time the thermal disinfecter is used.

WARNING MESSAGE	FREQUENCY
DRAIN FILTER CLEANING	25 CYCLES
HEPA FILTER REPLACEMENT	1000 CYCLES
GENERAL SERVICE	3000 CYCLES
HMD FILTER REPLACEMENT (only with active HANDPIECES H cycle)	250 "HANDPIECES H" cycles

### NOTE

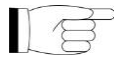

A REGULAR MAINTENANCE IS ESSENTIAL TO ACHIEVE THE BEST PERFORMANCE OF THE DEVICE. PERIODICALLY, A MESSAGE WILL BE DISPLAYED REQUESTING THAT THE ABOVE MAINTENANCE OPERATIONS ARE PERFORMED. FOR FURTHER INFORMATION OR IN CASE OF DOUBT, CONTACT THE TECHNICAL SERVICE: IF THEY HAVE PERFORMED REGULAR MAINTENANCE ON THE DEVICE, THE TECHNICIAN MIGHT HAVE ALREADY CARRIED OUT SOME OF THESE OPERATIONS.

- Do **not** wash the thermal disinfecter with direct jets of water, neither under pressure nor sprinkled. Seepage into electrical and electronic components could damage the operation of the device or its internal parts, even irreparably;
- Do **not** use abrasive cloths, metal brushes (or other aggressive materials) or products for metal cleaning, both solid and liquid, other than the recommended ones to clean the device or the washing chamber;
- Do **not** use unsuitable chemicals or inadequate disinfectants to clean plastic components and the washing chamber. In fact, these products can cause damages, even irreparably;
- Do **not** allow limescale or residues of other substances to accumulate in the washing chamber, on the door and on the gasket, but remove them at regular intervals. Such residues may damage these parts, besides compromising the operation of the hydraulic circuit components.

To remove any limescale deposits, run the DECALCIFICATION CYCLE by thoroughly following the relevant indications.



### DANGER

BEFORE PERFORMING ORDINARY MAINTENANCE, MAKE SURE THAT THE POWER CABLE PLUG IS REMOVED FROM THE MAINS SOCKET.

## DESCRIPTION OF MAINTENANCE INTERVENTIONS

Let's now look at the various operations to be carried out.

## CLEAN THE GASKET

To eliminate any traces of limestone or dirt, clean the gasket with a cotton cloth soaked in a soft solution of water and vinegar (or a similar product, checking the contents on the label before using).

Dry the surfaces and remove any residues before using the device.

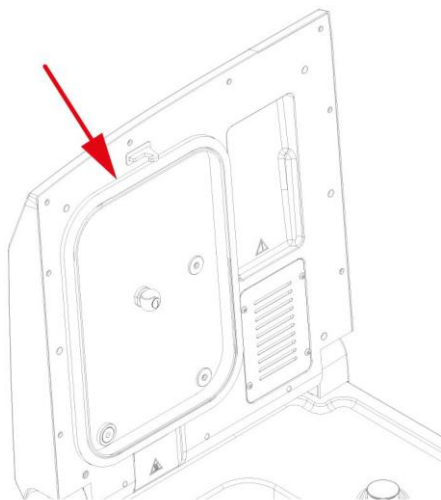

## CLEAN EXTERNAL SURFACES

Clean all the external parts using a clean cotton cloth dampened with water and, possibly, the addition of a neutral detergent.

Dry the surfaces and remove any residues before using the device.

## CLEAN WASHING CHAMBER

Clean the sterilization chamber (and internal surfaces in general) with a clean cotton cloth soaked in water and, possibly, a small amount of neutral detergent.

Rinse carefully with distilled water, taking care not to leave any type of residue in the sterilization chamber .

### **NOTE**



DO NOT USE POINTED OR SHARP TOOLS TO REMOVE POSSIBLE LIMESCALE FROM THE STERILIZATION CHAMBER. IF THERE ARE VISIBLE DEPOSITS, CHECK IMMEDIATELY THE PRESENCE OF SALT IN THE DECALCIFICATION SYSTEM.

### **NOTE**



THE PRESENCE OF BLACK SIGNS OF WEAR ON THE BOTTOM OF THE CHAMBER IS A KNOWN PHENOMENON DUE TO THE USE OF ULTRASOUND TECHNOLOGY FOR WASHING AND IT DOES NOT INDICATE FAULTS OR MALFUNCTIONS.

## CLEAN CHAMBER FILTERS

Remove the basket from the washing chamber.

Remove the filters (1) and (2) on the bottom of the chamber ensuring that possible residues do not drop inside the hole.

Rinse thoroughly the parts that compose filters (1) and (2) under running water and reposition them in their housings.

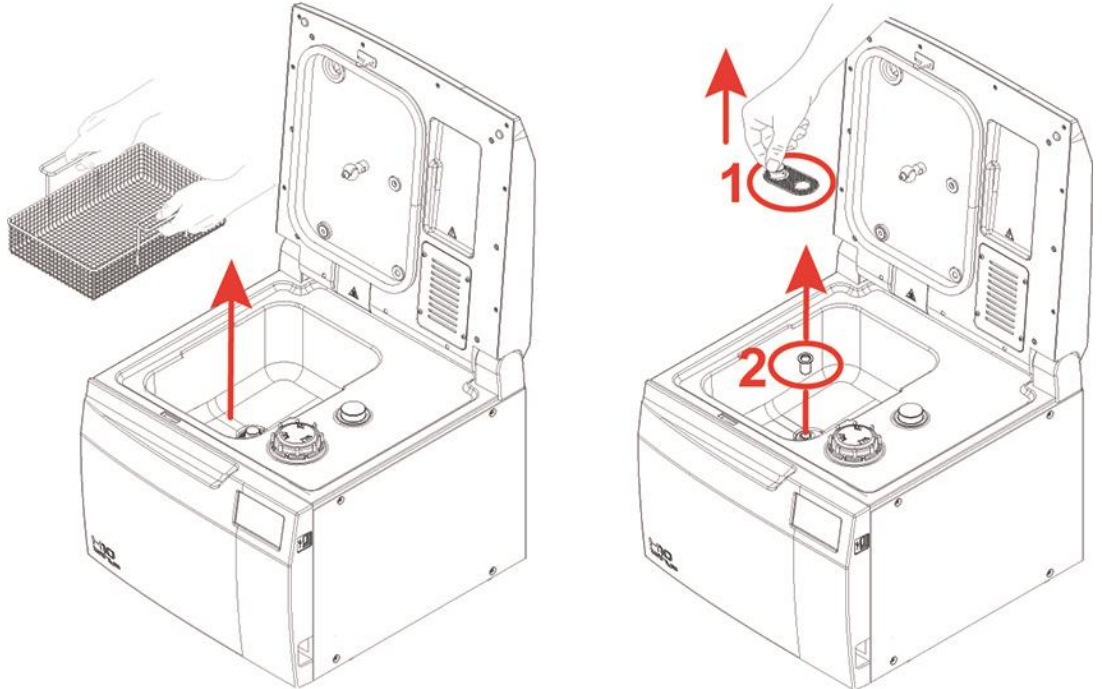

### NOTE



CORRECTLY PLACE FILTERS (1) AND (2) BACK IN THEIR RELEVANT HOUSINGS.

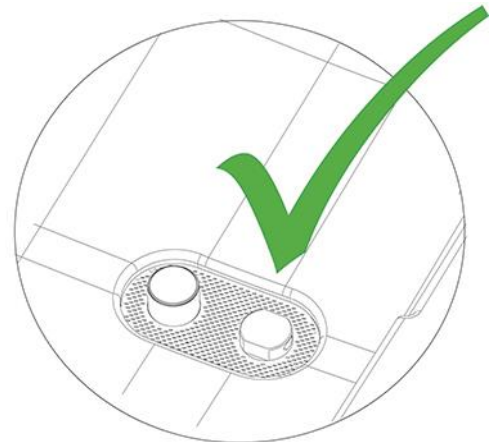
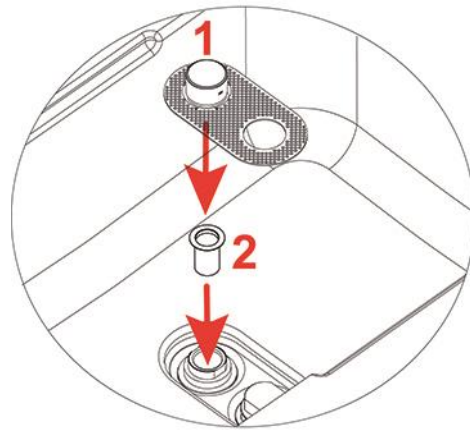

### NOTE



TO BE CLEANED, FILTER (1) DOES NOT HAVE TO BE COMPLETELY DISASSEMBLED. SHOULD FILTER BE DISASSEMBLED, RE-ASSEMBLE THE O-RING AS SHOWN IN THE FIGURE.

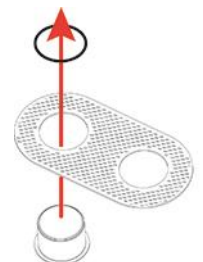

## HEPA FILTER REPLACEMENT

To remove HEPA filter, unscrew the 4 screws using the supplied Allen wrench. Disassemble the grid and replace the filter with a new one, then reassemble the grid.



### NOTE

REQUEST HEPA FILTER DIRECTLY FROM THE TECHNICAL SERVICE DEPARTMENT OF THE DEALER OR RESELLER THAT SUPPLIED THE PRODUCT.

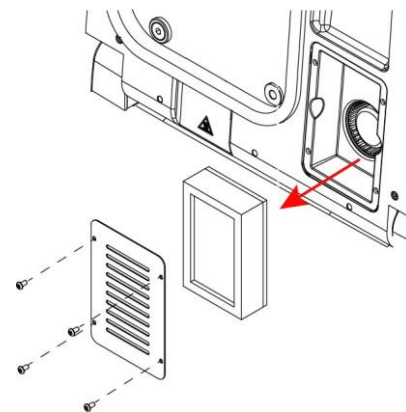
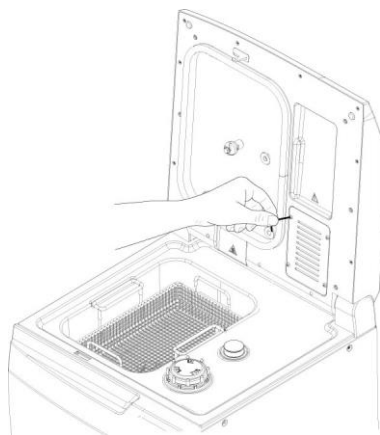

## CLEAN THE ROTARY NOZZLE

Remove the rotary nozzle using the Allen wrench supplied.

Carefully clean the nozzle under running water and, in case of limescale, use a specific limescale remover with a composition similar to the products recommended in chapter "DECALCIFICATION CYCLE".

Rinse thoroughly and reposition it in its housing using the Allen wrench supplied.

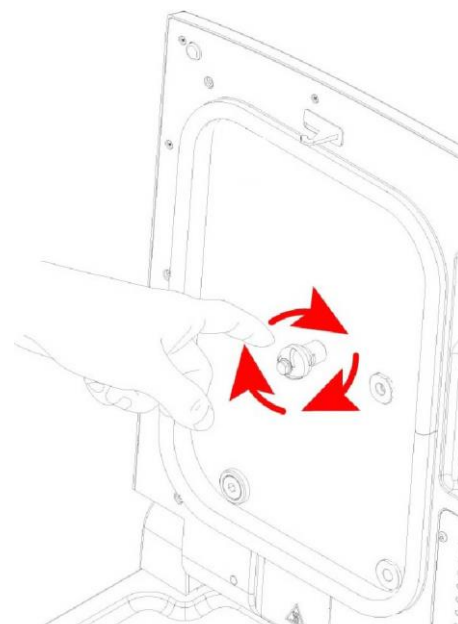
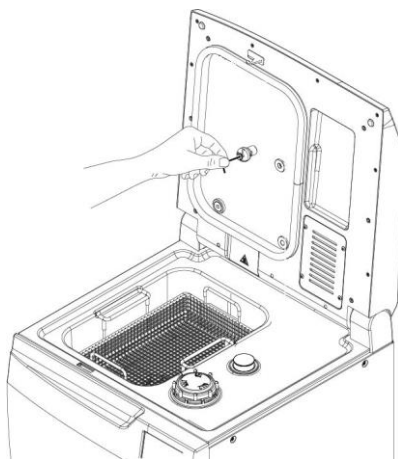

### WARNING

AT THE END OF THE ASSEMBLY CHECK THAT THE NOZZLE IS FREE TO ROTATE.

**The reference Standard for a thermo-disinfector performance is UNI EN ISO 15883.**

Referring to par. 6 of EN ISO 15883-1, in addition to the conformity to the device 'as supplied', borne by the manufacturer, the regulations require further checks on the device 'as installed' through a process called 'validation'. The validation process is borne by the user (responsible authority).

### **VALIDATION**

The validation process of a thermo-disinfector in accordance with EN ISO 15883-1 is composed of 3 different phases:

1. Installation qualification - IQ
2. Operational qualification - OQ
3. Performance qualification - PQ

#### **Installation qualification**

**IQ** - Process to obtain and document the evidence that the device has been supplied and installed in accordance with the relevant specification.

#### **Operational qualification**

**OQ** - Process to obtain and document the evidence that the device installed operates within the predefined limits when it is used according to its operational procedures.

#### **Performance qualification**

**PQ** - Process to obtain and document the evidence that the device, as installed and operated according to the operational procedures, works coherently as per predefined criteria and then the product meets its specifications.

#### **NOTE**

PERFORMANCE QUALIFICATION MUST BE CARRIED OUT AFTER THE COMPLETION OF INSTALLATION QUALIFICATION AND OPERATIONAL QUALIFICATION.



PERFORMANCE QUALIFICATION MUST BE CARRIED OUT WHEN INTRODUCING NEW OR MODIFIED OBJECTS TO CLEAN AND DISINFECT, OR NEW LOADING SYSTEMS, UNLESS THE EQUIVALENCE WITH A VALIDATED REFERENCE LOAD OR AN OBJECT OR A LOADING SYSTEM PREVIOUSLY VALIDATED HAS BEEN PROVEN.

PERFORMANCE QUALIFICATION MUST BE CARRIED OUT WHEN INTRODUCING NEW PROCESS PARAMETERS (INCLUDING PROCESS CHEMICALS).

Operational qualification should be repeated at predetermined intervals to check periodically the proper operation of the device.

We suggest to carry out performance qualification of the machine every year.

## DEVICE USEFUL LIFE

Ultrasound thermo-disinfector service life is of 10 years (average use: 5 cycles/day, for 220 days/year), in compliance with the routine maintenance prescriptions set forth in the use and maintenance manual.

This lapse of time, which is obviously not linked to an intrinsic "expiry date" of the product, is established based on the data inferred by the following evaluations:

- Average replacement ratio of the device by the user (turn-over);
- Device technological progress (availability of new technologies, publication of updated standards, launch of competitor's product defining a new "state of the art").

## DISPOSING THE EQUIPMENT WHEN NO LONGER USED

In compliance with Directive 2012/19/EU regarding restriction of the use of certain hazardous substances in electrical and electronic equipment along with waste electrical and electronic equipment, it is forbidden to dispose of this equipment in the municipal waste stream as unsorted municipal waste. When purchasing a new, equivalent piece of equipment, the old piece of equipment that has reached its end-of-life must be handed over to the reseller for proper disposal. As regards reuse, recycling and other forms of recovery of waste electrical and electronic equipment, the manufacturer carries out the functions set forth by laws and regulations currently in force in the individual countries.

The proper collection and separation of such equipment for recycling, treatment and disposal helps avoid any possible negative effects on the environment and health and facilitates the recycling of the materials of which the equipment is made. The symbol indicating separate collection for electrical and electronic equipment consists of the crossed out bin marked on the equipment.



### WARNING

IMPROPER DISPOSAL OF THE PRODUCT MAY RESULT IN THE APPLICATION OF SANCTIONS WHICH ARE DEFINED BY INDIVIDUAL NATIONAL LAWS.

## APPENDIX - GENERAL PROBLEMS FOREWORD

If while using the device a problem or an alarm occurs, this **DOES NOT** mean that the device is out of order.

It may not, in fact, be related to a breakdown but, more probably to an anomalous situation, often merely transitory (such as a blackout), or incorrect use.

In any case, it is important to first identify the cause of the failure and then take suitable corrective actions, either autonomously or with the intervention of the **Technical Service Department (see Appendix)**.

For this purpose, below, we provide instructions for diagnosing and resolving general problems, in addition to a precise description of the alarm codes, their meaning and their solution.

## TROUBLESHOOTING

If your thermo-disinfector is **not** working correctly, please make the following checks **before** contacting the Technical Service Department:

TROUBLE	POSSIBLE CAUSE	PROPOSED SOLUTION
The thermo-disinfector does not turn on.	The power cord is not plugged-in.	Plug it in.
	There is no voltage at the socket.	Check the cause of the lack of voltage at socket and fix it.
	The main switch and/or differential switch are turned to OFF.	Turn the switch to ON.
	The mains fuses are blown.	Replace with good fuses of equal nominal value. (See the Summary Table in <b>Appendix, Technical Characteristics</b> ).
Presence of water on the support surface of the thermo-disinfector.	Drainage pipe not properly connected.	Check the tightness of the union and, if necessary, reassemble it more carefully. Check that the pipe is completely inserted in the union; check the presence of hose clamps.
	Filling pipe not properly connected.	Check the proper tightening of the ring nut and the presence of the gasket between ring nut and union on machine side (for safety's sake, carry out the same check on the filling tap side as well).
Excessive humidity on the material and/or instruments at the end of the programme.	Excessive load in the basket	Check that the load does not exceed the maximum values allowed (See the Summary Table in <b>Appendix "Technical Characteristics"</b> ).
	Load not correctly positioned.	Position the load as per the indications. (See <b>Chapter "Preparing the material"</b> ).
	Accidental deactivation of drying	Check that drying is activated. If the problem occurs again, it is possible to increase the drying time (See <b>Chapter "Disinfection cycles"</b> ).
	HEPA filter clogged.	Replace HEPA filter. (See <b>Appendix "Maintenance"</b> ).
Traces of oxidation or spots on instruments	Compatibility of the instruments not adequate	Check the compatibility of instruments, making sure that the material they are made of is suitable to tolerate the thermal disinfection and the type of detergent.
	Ignored signalling of lack of salt	Add salt in the reservoir of the integrated water softening system. (See <b>paragraph Filling</b> ).
	Organic or inorganic residues on the instruments	Position the load as per the indications. If the material is particularly dirty, it is possible to extend the washing phase (See <b>Chapter "Custom cycles"</b> ). If necessary, remove manually stubborn dirt.
	Presence of ferrous residues on the sterilization chamber side.	Check that the hardness and the presence of iron ions in the water are within the prescribed limits. Clean the basket and the accessories as prescribed. (See <b>Appendix "Maintenance"</b> ).

**NOTE**

 IF THE PROBLEM PERSISTS, ADDRESS TO TECHNICAL SERVICE DEPARTMENT (SEE APPENDIX) COMMUNICATING THE MODEL AND SERIAL NUMBER OF THE THERMO-DISINFECTOR. THESE DATA ARE INDICATED IN THE REGISTRATION PLATE, ON THE REAR PART OF THE DEVICE.

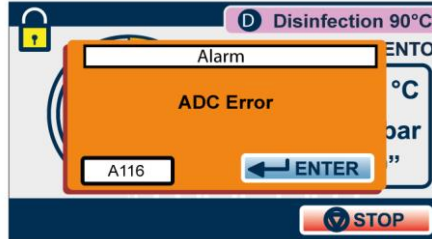

FOREWORD

Whenever an **anomalous condition** occurs during the operation of the thermal disinfecter, an alarm is generated, identified by a **specific code** (consisting of a letter followed by a 3-digit number).

Alarm codes are divided into **three categories**:

**E = ERROR/WARNING**

Incorrect handling and/or use, or a cause outside the device.

The problem can normally be solved by the user.

Code format: **Exxx** (xxx = identification number 000 + 999)

**A = ALARM**

First level fault

The problem can normally be solved on site by a specialised technician.

Code format: **Axxx** (xxx = identification number 000 + 999)

**H = HAZARD**

Second level fault

The problem can normally be solved by the Technical Service Centre.

Code format: **Hxxx** (xxx = identification number 000 + 999)

**S = SYSTEM ERROR**

Electronic system error (HW-FW).

Code format: **Sxxx** (xxx = identification number 000 + 999)

**NOTE**

 IN CASE OF ALARM, SWITCH OFF THE DEVICE ONLY AFTER HAVING FOLLOWED THE INDICATIONS DISPLAYED AND HAVING CARRIED OUT THE RESET (SEE 'RESETTING THE SYSTEM' PARAGRAPH).

ALARM INTERVENTION

The alarm intervention causes the **cycle interruption** (or the normal operation interruption), the display of the relevant **alarm code** and **message** and an **audible warning**.

The alarm procedure is designed in order not to give the user any possibility to **confuse** an anomalous cycle with an efficiently carried out one, and therefore **to unintentionally use unsterilised materials**; it is structured to guide the user up to the **RESET** of the thermo-disinfecter and the following use.

## SYSTEM RESET

The system can be reset in two alternative ways, depending on the type of alarm occurred (see the List of alarm codes below in this appendix):

- a) Pressing the OK button.
- b) Following the instructions displayed and holding down the RESET button for about 3 seconds:

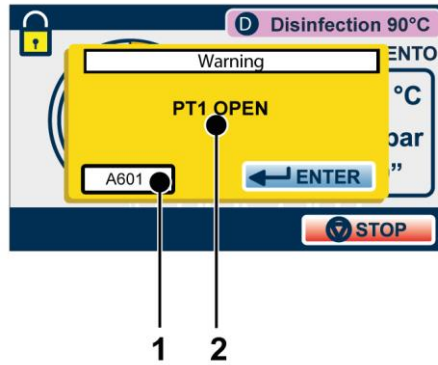

- 1) Error Code
- 2) Error Description

Once alarm procedure is completed, the indication of the following image is displayed. Pressing the RESET button for 3 seconds, the door is released and the device goes back to the initial menu.



After the RESET and any technical operation necessary to eliminate the fault, the device will be ready to perform a new programme.

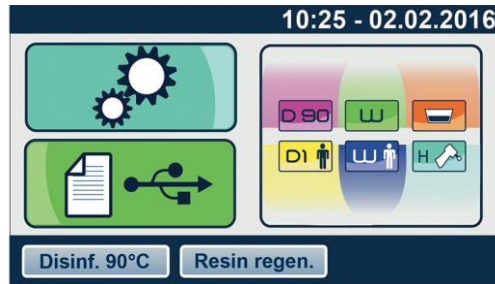

### WARNING



NEVER TURN OFF THE DEVICE BEFORE CARRYING OUT THE RESET. IF THE PROBLEM NEEDS THE INTERVENTION OF AN AUTHORIZED TECHNICIAN, AFTER THE RESET TURN OFF THE DEVICE AND CLOSE THE MAINS WATER TAP.

**ALARM CODES**

The list of alarm codes, the relevant messages displayed and RESET modes, are indicated in the following table:

**ERRORS (CATEGORY A)**

CODE	MESSAGE ON THE DISPLAY	DESCRIPTION	EXIT
A025	DOOR LOCK PROBLEM	Microswitch status inconsistent with door status	3 (in cycle) 2 (stand-by)
A070	RESIN REGENERATION PROBLEM	Lack of water flow from brine to resins during the regeneration phase	3
A116	ADC ERROR	Electronic system ADC error	3 (in cycle) 2 (stand-by)
A120	REFERENCE HEATING ELEMENT FAULT	Reference heating element acquisition chain fault.	3 (in cycle) 2 (stand-by)
A121	REFERENCE HEATING ELEMENT FAULT	Reference heating element acquisition chain fault.	3 (in cycle) 2 (stand-by)
A122	REFERENCE HEATING ELEMENT FAULT	Reference heating element acquisition chain fault.	3 (in cycle) 2 (stand-by)
A123	REFERENCE HEATING ELEMENT FAULT	Reference heating element acquisition chain fault.	3 (in cycle) 2 (stand-by)
A124	REFERENCE HEATING ELEMENT FAULT	Reference heating element acquisition chain fault.	3 (in cycle) 2 (stand-by)
A125	REFERENCE HEATING ELEMENT FAULT	Reference heating element acquisition chain fault.	3 (in cycle) 2 (stand-by)
A500	WATER FILLING PROBLEM	Water flow rate problem during water filling	3
A501	WATER LEVEL ABOVE MAX	Water presence above the foreseen maximum level.	3
A502	WATER FILLING SLOW	Water filling time beyond the maximum limit.	3
A503	WATER FILLING FAST	Water filling time beyond the minimum limit.	3
A504	AQUASTOP PROBLEM	"Aquastop" solenoid valve (EV3) malfunction	3
A551	DRAIN PROBLEM	Chamber emptying failed.	3
A552	FULL CHAMBER PROBLEM	Presence of water in the chamber when not required or level sensor fault.	1
A601	PT1 INTERRUPTED	Temperature sensor PT1 broken.	3 (in cycle) 2 (stand-by)
A602	PT2 INTERRUPTED	Temperature sensor PT2 broken.	3 (in cycle) 2 (stand-by)
A603	PT3 INTERRUPTED	Temperature sensor PT3 broken	3 (in cycle) 2 (stand-by)
A606	MPX INTERRUPTED	Pressure sensor for water level detection in the chamber failed.	3 (in cycle) 2 (stand-by)
A611	PT1 SHORT-CIRCUITED	Temperature sensor PT1 short-circuited.	3 (in cycle) 2 (stand-by)
A612	PT2 SHORT-CIRCUITED	Temperature sensor PT2 short-circuited.	3 (in cycle) 2 (stand-by)
A613	PT3 SHORT-CIRCUITED	Temperature sensor PT3 short-circuited	3 (in cycle) 2 (stand-by)
A616	MPX SHORT-CIRCUITED	Pressure sensor for water level detection short-circuited	3 (in cycle) 2 (stand-by)
A700	HEATING SYSTEM PROBLEM	Lack of water heating in the recirculation system or recirculation pump failed.	3
A701	DRYING PROBLEM	Fan not working efficiently or filter clogged.	3
A702	HEPA FILTER MISSING	Report the lack of HEPA filter.	3

CODE	MESSAGE ON THE DISPLAY	DESCRIPTION	EXIT
A703	DRYING PROBLEM	Drying heater malfunction	2
A902	US - DEGAS PROBLEM	DEGAS setting read by the US board memory other than the required value	2
A957	US UPDATE TRANSMISSION ERROR	Ultrasound board update error	2 (stand-by)
A958	US VOLTAGE PROBLEM	Incorrect US board power supply voltage	3

1 = OK (warning) + chamber emptying

2 = OK (warning)

3 = cycle interruption + OK + door unlock + reset 3

## ERRORS (CATEGORY E)

CODE	MESSAGE ON THE DISPLAY	DESCRIPTION	EXIT
E000	BLACKOUT	Black-Out.	3
E001	OVERVOLTAGE	Overvoltage.	3
E004	NETWORK FREQUENCY ERROR	Network frequency reading problem	3
E011	LID OPEN!	Attempt to start a cycle with lid open.	2
E552	WAIT!	Attempt to start a cycle with chamber drainage in progress after full chamber alarm	2
E070	SALT MIN LEVEL	Signal of salt float minimum level. It locks the machine after a number of cycles depending on set water hardness	2
E071	START CYCLE WITH REGENERATION	Signal to start a cycle with resin regeneration (Resin regeneration, Disinf. 90°C, Washing, D1 Custom, D2 Custom and W1 Custom)	2
E552	WAIT!	Attempt to start a cycle with chamber drainage in progress after full chamber alarm	2
E800	MIN DETERGENT LEVEL	Detergent level under the minimum level	2
E900	NO SET PW US	Power read by the US board memory other than the requested value	3
E901	POWER ABOVE / UNDER THRESHOLD	Power detected by the US board other than the set value	3
E957	US UPDATE IN PROGRESS	Ultrasound update in progress	2
E999	MANUAL INTERRUPTION	Manually interrupting the cycle	3

1 = OK (warning) + chamber emptying

2 = OK (warning)

3 = cycle interruption + OK + door unlock + reset 3

## ERRORS (CATEGORY H)

CODE	MESSAGE ON THE DISPLAY	DESCRIPTION	EXIT
H410	TIMER ERROR	Error in time information (align with autoclave).	3
H560	DELTA PT1-PT2 ERROR	Difference of temperature over the limit between Pt1 (regulation probe) and Pt2 (control probe) during the washing phase	3
H561	TEMPERATURE ABOVE MAX LIMIT	Temperature PT1 above the permitted limit for the washing phase.	3
H562	TEMPERATURE BELOW MIN LIMIT	Temperature PT1 below the permitted limit for the washing phase	3
H650	LEVEL ABNORMAL DECREASE	Abnormal reduction of water level during the washing phase.	3
H651	LEVEL ABNORMAL INCREASE	Abnormal increase of water level during the washing phase.	3
H652	LEVEL ABNORMAL DECREASE	Abnormal decrease of water level during the disinfection phase.	3
H653	LEVEL ABNORMAL INCREASE	Abnormal increase of water level during the disinfection phase.	3
H750	DELTA PT1-PT2 ERROR	Difference of temperature above the limit between Pt1 (regulation probe) and Pt2 (control probe) during the thermal disinfection phase.	3
H751	TEMPERATURE ABOVE MAX LIMIT	Temperature PT1 above the permitted limit for thermal disinfection phase.	3
H752	TEMPERATURE BELOW MIN LIMIT	Temperature PT1 below the permitted limit for thermal disinfection phase.	3
H801	DETERGENT DOSING DEVICE PROBLEM	Excessive detergent dosing time.	3
H950	US - COMMUNICATION INTERRUPTED	Ultrasound switching off resulting from a temporary lack of communication.	3
H951	US – SONOTRODE DISCONNECTED	Malfunction of one or more sonotrodes of the ultrasound system	3
H952	US - MAX CURRENT	Overcurrent in the ultrasound system	3
H953	US - RESONANCE FREQUENCY	Lack of tuning in the ultrasound system	3
H954	US - COMMUNICATION ERROR	No communication between control board and ultrasound board	3 (in cycle) 2 (stand-by)
H955	US - POWER LOW	Low power of ultrasounds during the washing phase.	3
H956	US - CRC ERROR	Ultrasound board software CRC check failed	3 (in cycle) 2 (stand-by)
H957	ULTRASOUND DISABLED	Ultrasound disabled	3 (in cycle) 2 (stand-by)

1 = OK (warning) + chamber emptying

2 = OK (warning)

3 = cycle interruption + OK + door unlock + reset 3

## ERRORS (CATEGORY S)

CODE	MESSAGE ON THE DISPLAY	DESCRIPTION	EXIT
S001	FLASH NOT ACCESSIBLE	Flash memory not accessible	2
S002	FLASH FULL	Flash memory full.	2
S003	SD CARD NOT ACCESSIBLE	Micro SD card not accessible for data storage during the start-up phase.	2
S004	SD CARD FULL	Micro SD Card full	2
S005	USB STICK ERROR	USB stick not accessible (interruption of communication after download started successfully).	2
S006	USB STICK NOT ACCESSIBLE	USB Stick not accessible (before download start)	2
S007	USB STICK FULL	USB Stick full	2
S008	SD CARD NOT ACCESSIBLE	Micro SD Card not accessible during data storage phase	2
S018	IMPOSSIBLE TO OPEN CRC FILE	CRC file inside SD card cannot be opened	2
S020	RUN BACKUP	Report of cycles still to be downloaded recommended limit has been reached.	2
S021	OVERWRITE DATA	Report of cycles still to be downloaded limit in case of SD Card malfunction has been reached.	2
S030	SYSTEM ERROR	Malfunction in software running.	2 (out of cycle) 3 (in cycle)
S031	SYSTEM ERROR	Malfunction in software running.	2 (out of cycle) 3 (in cycle)
S032	SYSTEM ERROR	Malfunction in software running.	2 (out of cycle) 3 (in cycle)
S033	SYSTEM ERROR	Malfunction in software running	2 (out of cycle) 3 (in cycle)
S100	INCONSISTENT STATUS	Software problem in the management of the correct sequence of events	3

1 = OK (warning) + chamber emptying

2 = OK (warning)

3 = cycle interruption + OK + door unlock + reset 3

## TROUBLESHOOTING

According to the **type of alarm** occurred, please find below the indications to detect the possible causes and restore the proper operation:

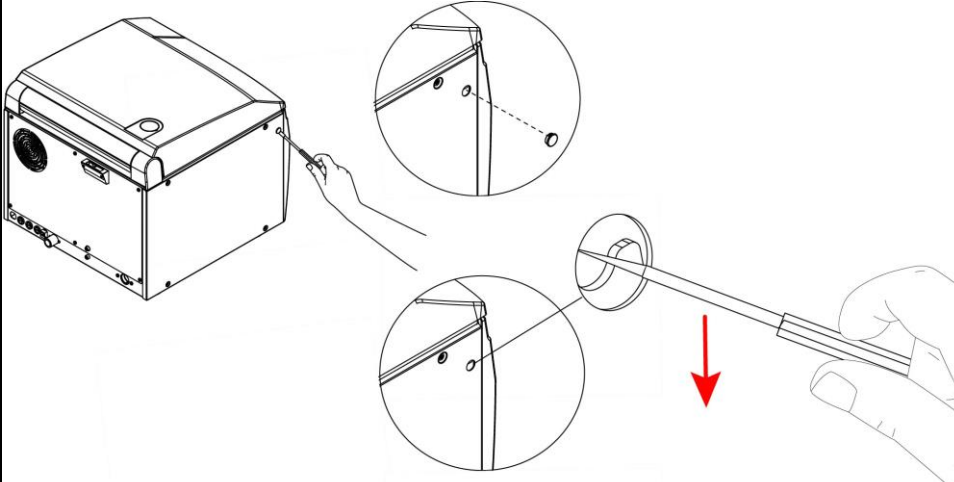
ERRORS (CATEGORY A)		
CODE	POSSIBLE CAUSE	SOLUTION
A025	<p>Microswitch or door locking system magnet fault.</p> 	<p>Contact the Technical Service Department. If the instruments need to be extracted, it is possible to manually open the door as shown in the figure:</p>
A070	Clogging of the water circuit. Failure or clogging of SV1.	<p>Open water filling cock. Check mains water pressure. If the problem persists, contact the Technical Service Department.</p>
	Insufficient mains water pressure or flow.	
A116	Control board failure.	If the problem persists, contact the Technical Service Department.
A120	Control board failure.	If the problem persists, contact the Technical Service Department.
A121	Control board failure.	If the problem persists, contact the Technical Service Department.
A122	Control board failure.	If the problem persists, contact the Technical Service Department.
A123	Control board failure.	If the problem persists, contact the Technical Service Department.
A124	Control board failure.	If the problem persists, contact the Technical Service Department.
A125	Control board failure.	If the problem persists, contact the Technical Service Department.
A500	Insufficient mains water pressure or flow.	<p>Check pressure and flow of mains water. If they are insufficient (see technical data table), check the filter condition in the connection union to the cock. Check if a connection point to the mains with adequate characteristics is available or contact your plumber. If the problem persists, contact the Technical Service Department.</p>
	Filter clogging in filling union on cock side.	
	Partial clogging of SV2.	
	Failure of SV2 flow limiter.	
A501	Failure of level sensor or leakage in SV2 or SV1. Failure in flow reducers.	Close the water filling cock and contact the Technical Service Department.

ERRORS (CATEGORY A)		
CODE	POSSIBLE CAUSE	SOLUTION
A502	Insufficient mains water pressure or flow. Partial clogging of internal water circuit. Partial clogging of SV2. SV3 clogging. Filter clogging in filling union on cock side Water filling cock closed.	Check that filling water cock is open. Check pressure and flow of mains water. If they are insufficient (see technical data table), check the filter condition in the connection union to the cock. Check if a connection point to the mains with adequate characteristics is available or contact your plumber. If the problem persists, contact the Technical Service Department.
A503	Level sensor failure. Breakage of SV2 pressure reducer.	Contact the technical service department.
A504	SV3 malfunction	Contact the Technical Service Department.
A551	Pipe clogged or presence of a back pressure in the drain circuit or in a pipe siphon. Failure or malfunction of the drain pump. Chamber drainage opening clogged.	Check that the drain pipe is neither kinked nor squashed. Check that the drainage is in good working order and that there are no siphons. Check the drainage opening in the chamber. If the problem persists, contact the Technical Service Department.
A552	Fluid filling in the chamber during stand-by phase or with machine off.	The chamber will be automatically emptied by the drain pump. Perform a pre-washing cycle to rinse any residues of aggressive chemicals.
	Level sensor failure. Solenoid valve leakage.	Close the cock and contact the Technical Service Department.
A601	Temperature sensor PT1 broken.	Contact the Technical Service Department.
A602	Temperature sensor PT2 broken.	Contact the Technical Service Department.
A603	Temperature sensor PT3 failed	Contact the Technical Service Department
A606	Pressure sensor for water level detection in the chamber failed.	Contact the Technical Service Department.
A611	Temperature sensor PT1 short-circuited.	Contact the Technical Service Department.
A612	Temperature sensor PT2 short-circuited.	Contact the Technical Service Department.
A613	Temperature sensor PT3 short-circuited	Contact the Technical Service Department
A616	Pressure sensor for water level detection short-circuited.	Contact the Technical Service Department.
A700	Clogging of rotary nozzle.	Check that the rotary nozzle is free to rotate and without scaling. If necessary, disassemble and clean it (see "Ordinary maintenance" section). If the problem persists, contact the Technical Service Department.
	Heater failure or safety thermostat tripping. Clogging or failure of the recirculation pump.	Contact the Technical Service Department.
A701	Fan not working efficiently	Repeat the cycle and, if the problem persists, contact the Technical Service Department
	HEPA filter clogged.	Replace the filter or contact the Technical Service Department.
A703	Drying heater malfunction	Contact the Technical Service Department.
A902	DEGAS setting read by the US board memory other than the required value	Repeat the cycle and, if the problem persists, contact the Technical Service Department
A957	Corrupted ultrasound board update files	Contact the Technical Service Department.
A958	Power supply voltage: <100Vac; ranging between 150Vac and 180Vac; > 270Vac.	Contact your electrician to check the system. If the problem persists, contact the Technical Service Department.



ERRORS (CATEGORY E)		
CODE	POSSIBLE CAUSE	SOLUTION
E000	Power blackout during the cycle.	Check the continuous presence of power supply. If the blackout persists and the instruments need to be extracted, the door can be manually opened as shown in the figure:
	Power plug disconnected during the cycle.	Check that the plug is correctly plugged in.
	Main switch turned to OFF during the cycle.	Do not turn off the machine during a cycle.
E001	Voltage too high in the power supply electric system.	Contact your electrician to check the system.
E004	No network voltage frequency detection.	Contact the Technical Service Department.
E011	Attempt to start a cycle with lid open.	Close the lid.
E552	Attempt to start a cycle with chamber drainage in progress after full chamber alarm.	Wait for the chamber drainage phase to be completed after full chamber alarm.
E070	Lack of salt in the suitable container. Salt level sensor failure.	Add salt (see "Adding salt" section). If the problem persists, contact the Technical Service Department.
E071	Signal to start a cycle with resin regeneration since the number of performed cycles without regeneration has been reached	Start a cycle with resin regeneration (Resin regeneration, Disinf. 90°C, Washing, D1 Custom, D2 Custom and W1 Custom)
E552	Attempt to start a cycle with chamber drainage in progress after full chamber alarm.	Wait for the chamber drainage phase to be completed after full chamber alarm.
E800	Not enough detergent to perform a cycle.	Detergent level sensor failure. Add detergent (see "Detergent tank filling" section). If the problem persists, contact the Technical Service Department.
E900	Power read by US board memory other than the set value.	Repeat the cycle and, if the problem persists, contact the Technical Service Department
E901	Power detected by the US board other than the set value.	Repeat the cycle and, if the problem persists, contact the Technical Service Department
E957	US UPDATE IN PROGRESS	
E999	Voluntary manual interruption of a programme using the 'STOP' button.	

ERRORS (CATEGORY H)		
CODE	POSSIBLE CAUSE	SOLUTION
H410	Malfunction of electronic control board.	If the problem persists, contact the Technical Service Department.
H560	Malfunction in temperature detection during washing.	If the problem persists, contact the Technical Service Department.
H561	Too high temperature during washing.	If the problem persists, contact the Technical Service Department.
H562	Too low temperature during washing. Presence of excessive load.	Repeat the cycle by removing a part of the load. If the problem persists, contact the Technical Service Department
H650	Presence of water leakage in the internal water circuit or malfunction in level detection during the washing phase. Wrong drain system connection.	In case of leakage, close the water filling cock and contact the Technical Service Department.  Make sure that the drain system is correctly connected.
H651	Solenoid valve leakage or malfunction in level detection during the washing phase.	Close the water filling cock and contact the Technical Service Department.
H652	Presence of water leakage in the internal water circuit or malfunction in level detection during the thermal disinfection phase. Wrong drain system connection.	In case of leakage, close the water filling cock and contact the Technical Service Department.  Make sure that the drain system is correctly connected.
H653	Solenoid valve leakage or malfunction in level detection during the thermal disinfection phase.	Close the water filling cock and contact the Technical Service Department.
H750	Malfunction in temperature detection during thermal disinfection.	If the problem persists, contact the Technical Service Department.
H751	Too high temperature during thermal disinfection.	If the problem persists, contact the Technical Service Department.
H752	Too low temperature during thermal disinfection. Presence of excessive load.	Repeat the cycle by removing a part of the load. If the problem persists, contact the Technical Service Department.
H801	"Detergent circuit clogging. Failure or malfunction of detergent pump. Detergent flowmeter failure. Presence of air inside the circuit'.	If the problem persists, contact the Technical Service Department.
H950	Unstable communication between control board and ultrasound board.	If the problem persists, contact the Technical Service Department.
H951	Lack of power supply or one or more sonotrodes failed or damaged connection between transducers and ultrasound board.	If the problem persists, contact the Technical Service Department.
H952	Malfunction or failure of ultrasound board or of one or more transducers.	If the problem persists, contact the Technical Service Department.
H953	Malfunction or failure of ultrasound board or of one or more transducers.	If the problem persists, contact the Technical Service Department.
H954	Lack of communication between control board and ultrasound board.	If the problem persists, contact the Technical Service Department.
H955	Too low machine power supply voltage. Insufficient ultrasound power.	If the problem persists, contact the Technical Service Department.
H956	Ultrasound board internal memory corruption. Update attempt with corrupted file.	Update ultrasound board software. If the problem persists, contact the Technical Service Department.
H957	Ultrasound disabled from the service menu	Turn off and on again, if the problem persists, contact the Technical Service Department.

ERRORS (CATEGORY S)		
CODE	POSSIBLE CAUSE	SOLUTION
S001	Control board failure.	If the problem persists, contact the Technical Service Department.
S002	Control board failure.	If the problem persists, contact the Technical Service Department.
S003	Control board failure.	If the problem persists, contact the Technical Service Department.
S004	Control board failure.	If the problem persists, contact the Technical Service Department.
S005	USB Stick failure.	Replace the USB stick and repeat the download operation.
S006	Non-compatible or faulty USB stick.	Ensure that the USB stick is in good working order, by inserting it in a PC. Check that formatting is correct (see "Technical data" section). If the problem persists, try with a different USB stick. If the problem still persists, contact the Technical Service Department.
S007	USB stick with insufficient space or write-protected. Too many files in the main directory.	Remove writing protection or free up memory (at least in part) on the USB stick.
S008	Control board failure	If the problem persists, contact the Technical Service Department.
S018	Control board failure.	If the problem persists, contact the Technical Service Department.
S020	Report of cycles still to be downloaded recommended limit has been reached.	Download cycle reports through the "New" option.
S021	Report of cycles still to be downloaded limit (500) in case of SD Card malfunction has been reached. If reports are not downloaded, data will be overwritten and permanently lost.	Download cycle reports through the "New" option. If the problem persists, contact the Technical Service Department.
S030	Malfunction in software running. Check, using a watchdog, that one of the main processes is not in lock condition.	If the problem persists, contact the Technical Service Department.
S031	Malfunction in software running. Check, using a hardware watchdog, that one of the peripherals is not in lock condition.	If the problem persists, contact the Technical Service Department.
S032	Malfunction in software running. Check, using a watchdog, that one of the main processes is not in lock condition (e.g. infinite loop).	If the problem persists, contact the Technical Service Department.
S033	Malfunction in software running	If the problem persists, contact the Technical Service Department.
S100	Malfunction in software running.	Restart the thermal disinfectant and, if the problem persists, contact the Technical Service Department.

## APPENDIX - ADMIN USER PIN RESET



IF ADMIN USER ENTERS THE PIN INCORRECTLY FOR 3 TIMES, IT IS NECESSARY TO ENTER THE FOLLOWING UNLOCK PIN WHEN YOU WILL BE PROMPTED TO ENTER PIN AGAIN:

**9999**

FOR ANY REQUEST OF  
TECHNICAL INTERVENTION ON THE PRODUCT,  
BOTH UNDER WARRANTY AND OUT OF WARRANTY,  
APPLY DIRECTLY  
**TO THE TECHNICAL SERVICE DEPARTMENT**  
OF THE DEALER OR RESELLER  
THAT SUPPLIED THE PRODUCT.



**WARNING**

BEFORE CARRYING OUT ANY TECHNICAL SERVICE OPERATIONS,  
CONSULT THE SERVICE MANUAL CONTAINING THE ABOVE  
INSTRUCTIONS.

We will gladly provide any information you may need on the product as well as give you suggestions and advice on the washing and thermal disinfection procedures.

In this regard, please refer to the following address:

Manufactured by  
CEFLA sc  
Sede Legale ed Amministrativa / Head Quarter  
Via Selice Provinciale, 23/a – 40026 Imola (BO) Italy  
Stabilimento / Plant  
Via Bicocca, 14/c – 40026 Imola (BO) Italy

<http://www.anthos.it>

<http://www.sternweber.it>

<http://www.castellini.it>

<http://www.mocom.it>



[www.cefla.com](http://www.cefla.com)