

series48



operator's manual



An Excel Technology Company

4600 Campus Place
Mukilteo, WA 98275 USA
1.800.SYNRAD1
tel 1.425.349.3500
fax 1.425.349.3667
e-mail synrad@synrad.com
www.synrad.com

series48

Series J48 Lasers Operator's Manual

Model 48-1

Model 48-2

Model 48-5

Version 6.0

Released April 2005

Part number 900-00007-03



An Excel Technology Company

4600 Campus Place
Mukilteo, WA 98275 USA
1.800.SYNRAD1
tel 1.425.349.3500
fax 1.425.349.3667
e-mail synrad@synrad.com
www.synrad.com

table of contents

Laser Safety

Hazard information.....	1
Terms.....	1
General hazards.....	1
48-1 label locations.....	3
48-2 label locations.....	4
48-5 label locations.....	5
Agency compliance.....	6
Center for Devices and Radiological Health (CDRH) requirements.....	6
Federal Communications Commission (FCC) requirements.....	7
European Union (EU) requirements.....	8
Declaration of Conformity.....	10

Getting Started 1

Introduction.....	1-2
Series 48 nomenclature.....	1-2
Unpacking.....	1-3
Incoming inspection.....	1-3
Packaging guidelines.....	1-3
Inventory.....	1-4
Contents description.....	1-5
Mounting.....	1-6
Standard mounting.....	1-6
With an FH Series marking head.....	1-6
Connecting.....	1-7
Air-cooled connections.....	1-7
Water-cooled connections.....	1-8
Electrical connections.....	1-12
Control connections.....	1-14
DB9 connections.....	1-15

Operation 2

Controls and indicators.....	2-2
Initial start-up.....	2-4
With a UC-2000 Controller.....	2-4
Without a UC-2000 Controller.....	2-6

Technical Reference 3

Technical overview.....	3-2
Introduction.....	3-2
Plasma section.....	3-3
Optical resonator.....	3-3

table of contents

Technical Reference (cont.)

Control circuitry	3-4
Optical setup	3-7
Controlling laser power	3-9
Control signals	3-9
Operating modes	3-11
DB9 connections	3-14
Integrating Series 48 safety features	3-16
Keyswitch functions	3-16
Remote interlock functions	3-17
Series 48 general specifications	3-18
Model 48-1 package outline drawing	3-20
Model 48-2 package outline drawing	3-21
Model 48-5 package outline drawing	3-22

Maintenance/Troubleshooting 4

Maintenance	4-2
Disabling the laser	4-2
Daily inspections	4-2
Storage/shipping	4-2
Troubleshooting	4-3
Introduction	4-3
J48 interconnect schematic	4-4
J48 control board schematic	4-5
Resetting faults	4-6
Laser faults	4-7
Beam delivery optics	4-9

Appendix A

Closed Loop Stabilization Kit	A-2
Introduction	A-2
Safety precautions	A-2
Connecting	A-3
Operation	A-4
Closed loop specifications	A-4

Index

table of contents

List of Figures

Figure 1	48-1 hazard label and CE label locations	3
Figure 2	48-2 hazard label and CE label locations	4
Figure 3	48-5 hazard label and CE label locations	5
Figure 4	European compliance mark	8
Figure 1-1	Series 48 shipping box contents	1-4
Figure 1-2	48-1 / 48-2 cooling fan placement	1-7
Figure 1-3	48-1 / 48-2 cooling connections	1-10
Figure 1-4	48-5 cooling connections	1-11
Figure 1-5	DC-1 (Astec) power supply	1-12
Figure 1-6	DC-2/DC-5 (Power-One) power supplies	1-13
Figure 1-7	Typical Series 48 system interconnection diagram	1-16
Figure 2-1	48-1 / 48-2 controls and indicators	2-2
Figure 2-2	48-5 controls and indicators	2-3
Figure 3-1	Average laser output vs. percent PWM duty cycle	3-2
Figure 3-2	Cross section of tube	3-3
Figure 3-3	Beam characteristics	3-4
Figure 3-4	RF Driver IV	3-6
Figure 3-5	“Flying optics” beam path	3-7
Figure 3-6	Tickle pulse waveform	3-9
Figure 3-7	Series 48 waveforms	3-10
Figure 3-8	PWM Command signal waveform	3-11
Figure 3-9	Factory-installed DB9 jumper plug wiring	3-14
Figure 3-10	Model 48-1 package outline and mounting dimensions	3-20
Figure 3-11	Model 48-2 package outline and mounting dimensions	3-21
Figure 3-12	Model 48-5 package outline and mounting dimensions	3-22
Figure 4-1	Model J48 Series interconnect schematic	4-4
Figure 4-2	J Series control board schematic	4-5
Figure A-1	Typical closed loop setup	A-3

table of contents

List of Tables

Table 1 Class IV safety features 9

Table 1-1 Ship kit contents 1-4

Table 1-2 Dew point temperatures 1-9

Table 3-1 Gas purity specifications 3-8

Table 3-2 PWM Command signal levels 3-12

Table 3-3 Remote Keyswitch and Remote Interlock signal specifications 3-14

Table 3-4 DB9 pin assignments 3-15

Table 3-5 Series 48 general specifications 3-18

Table 4-1 Series 48 cooling specifications 4-8

Table A-1 Closed loop general specifications A-4

Warranty information

This is to certify that Series 48 lasers are guaranteed by SYNRAD, Inc. to be free of all defects in materials and workmanship for a period of one year from the date of purchase. This warranty does not apply to any defect caused by negligence, misuse (including environmental factors), accident, alteration, or improper maintenance.

If, within one year from the date of purchase, any part of the Series 48 laser should fail to operate, contact the SYNRAD Customer Service department at 1.800.SYNRAD1 (outside the U.S. call 1.425.349.3500) and report the problem. When calling for support, please be prepared to provide the date of purchase, model number and serial number of the unit, and a brief description of the problem. When returning a unit for service, a Return Authorization (RA) number is required; this number must be clearly marked on the outside of the shipping container in order for the unit to be properly processed. If replacement parts are sent to you, then you are required to send the failed parts back to SYNRAD for evaluation unless otherwise instructed.

If your Series 48 laser fails within the first 45 days after purchase, SYNRAD, Inc. will pay all shipping charges to and from SYNRAD when shipped as specified by SYNRAD Customer Service. After the first 45 days, SYNRAD will continue to pay for the costs of shipping the repaired unit or replacement parts back to the customer from SYNRAD. The customer, however, will be responsible for shipping charges incurred when sending the failed unit or parts back to SYNRAD or a SYNRAD Authorized Distributor. In order to maintain your product warranty and to ensure the safe and efficient operation of your Series 48 laser, only authorized SYNRAD replacement parts can be used. This warranty is void if any parts other than those provided by SYNRAD, Inc. are used.

SYNRAD, Inc. and SYNRAD Authorized Distributors have the sole authority to make warranty statements regarding SYNRAD products. SYNRAD, Inc. and its Authorized Distributors neither assumes nor authorizes any representative or other person to assume for us any other warranties in connection with the sale, service, or shipment of our products. SYNRAD, Inc. reserves the right to make changes and improvements in the design of our products at any time without incurring any obligation to make equivalent changes in products previously manufactured or shipped. Buyer agrees to hold SYNRAD harmless from any and all damages, costs, and expenses relating to any claim arising from the design, manufacture, or use of the product, or arising from a claim that such product furnished Buyer by SYNRAD, or the use thereof, infringes upon any Patent, foreign or domestic.

Trademark/copyright information

Duo-Lase and Power Wizard are registered trademarks of SYNRAD, Inc.

All other trademarks or registered trademarks are the property of their respective owners.

© 2005 by SYNRAD, Inc.
All rights reserved.

Contact information

Worldwide headquarters

SYNRAD's worldwide headquarters are located north of Seattle in Mukilteo, Washington, U.S.A. Our mailing address is:

SYNRAD, Inc.
4600 Campus Place
Mukilteo, WA 98275
U.S.A.

Phone us at: 1.800.SYNRAD1 (1.800.796.7231)
Outside the U.S.: 1.425.349.3500
Fax: 1.425.349.3667
Email: synrad@synrad.com

Sales and Applications

SYNRAD's Regional Sales Managers work with customers to identify and develop the best CO₂ laser solution for a given application. Because they are familiar with you and your laser application, use them as a first point of contact when questions arise. Regional Sales Managers also serve as the liaison between you and our Applications Lab in processing material samples per your specifications. To speak to the Regional Sales Manager in your area, call SYNRAD at 1.800.SYNRAD1.

Customer Service

For assistance with order or delivery status, service status, or to obtain a Return Authorization (RA) number, contact SYNRAD at 1.800.SYNRAD1 and ask to speak to a Customer Service representative.

Technical Support

SYNRAD's Regional Sales Managers are able to answer many technical questions regarding the installation, use, troubleshooting, and maintenance of our products. In some cases, they may transfer your call to a Laser, Marking Head, or Software Support Specialist. You may also email questions to the Technical Support Group by sending your message to support@synrad.com or to support@winmark.com.

Reference materials

Your Regional Sales Manager can provide reference materials including Outline & Mounting drawings, Operator's Manuals, Technical Bulletins, and Application Newsletters. Most of these materials are also available directly from SYNRAD's web site at <http://www.synrad.com>.

European headquarters

SYNRAD's European subsidiary, Excel Technology Europe GmbH, covers Austria, Germany, and Italy. Contact Excel Technology at:

Excel Technology Europe GmbH
Münchner Str. 2a
D-82152 Planegg
Germany

Phone: 49 89 891 462-0
Fax: 49 89 891 462-69

laser safety

Hazard information

Hazard information includes terms and symbols used in this manual or on the equipment to alert both operating and service personnel to the recommended precautions in the care, use, and handling of laser equipment.

Terms

Certain terms are used throughout this manual or on the equipment labels. Please familiarize yourself with their definitions and significance.

- ⚠ Danger:** Imminent hazards which, if not avoided, will result in death or serious injury.
- ⚠ Warning:** Potential hazards which, if not avoided, could result in death or serious injury.
- ⚠ Caution:** Potential hazards or unsafe practices which, if not avoided, may result in minor or moderate injury.
- Caution:** Potential hazards or unsafe practices which, if not avoided, may result in product damage.
- Note:** Points of particular interest for more efficient or convenient equipment operation; additional information or explanation concerning the subject under discussion.

General hazards

Following are descriptions of general hazards and unsafe practices that could result in death, severe injury, or product damage. Specific warnings and cautions not appearing in this section are found throughout the manual.

⚠ Warning

serious
personal
injury

This product emits invisible infrared laser radiation at the 10.6 μm CO_2 wavelength. Since direct or diffuse laser radiation can inflict severe corneal injuries, always wear eye protection when in the same area as an exposed laser beam. Eyewear protects against scattered energy and is not intended to protect against direct viewing of the beam or reflections from metallic surfaces. Protective eyewear that blocks 10.6 μm CO_2 laser radiation is available from SYNRAD, Inc.

Enclose the beam path whenever possible. Direct or diffuse laser radiation can seriously burn human or animal tissue.

U.S. customers should refer to and follow the laser safety precautions in ANSI Z136.1-1993, *American National Standard for Safe Use of Lasers*. Procedures listed under the Standard include the appointment of a Laser Safety Officer, operation of the product in an area of limited access by trained personnel, servicing of equipment only by trained and authorized personnel, and posting of signs warning of the potential hazards.

European customers should refer to and follow the laser safety precautions in EN 60825-1, *Safety of Laser Products – Part 1: Equipment Classification, Requirements, and User's Guide*.

laser safety

Hazard information

Warning

serious
personal
injury

Materials processing can generate air contaminants such as vapors, fumes, and/or particles that may be noxious, toxic, or even fatal. Material Safety Data Sheets (MSDS) for materials being processed should be thoroughly evaluated and the adequacy of provisions for fume extraction, filtering, and venting should be carefully considered. Review the following references for further information on exposure criteria:

ANSI Z136.1-1993, *American National Standard for Safe Use of Lasers*, section 7.3.

U.S. Government's *Code of Federal Regulations*: 29 CFR 1910, Subpart Z.

Threshold Limit Values (TLV's) published by the American Conference of Governmental Industrial Hygienists (ACGIH).

It may be necessary to consult with local governmental agencies regarding restrictions on the venting of processing vapors.

Caution

possible
personal
injury

The use of controls or adjustments or performance of procedures other than those specified herein may result in hazardous radiation exposure.

Other hazards

The following hazards would be typical for this product family when incorporated for intended use: (A) risk of injury when lifting or moving the unit; (B) risk of exposure to hazardous laser energy through unauthorized removal of access panels, doors, or protective barriers; (C) risk of exposure to hazardous laser energy and injury due to failure of personnel to use proper eye protection or failure to adhere to applicable laser safety procedures; (D) generation of hazardous air contaminants that may be noxious, toxic, or even fatal.

Additional laser safety information

The SYNRAD web site (<http://www.synrad.com/LaserFacts/lasersafety.html>) contains an online laser safety handbook that provides information on (1) Laser Safety Standards for OEM's/System Integrators; (2) Laser Safety Standards for End Users; (3) References and Sources; and (4) Assistance with Requirements.

In addition, the Occupational Safety and Health Administration (OSHA) has an online Technical Manual located at http://www.osha-slc.gov/dts/osta/otm/otm_iii/otm_iii_6.html. Section III, Chapter 6 and Appendix III are good resources for laser safety information.

Another excellent laser safety resource is the Laser Institute of America (LIA). Their comprehensive web site is located at <http://www.laserinstitute.org>.

laser safety

48-1 label locations

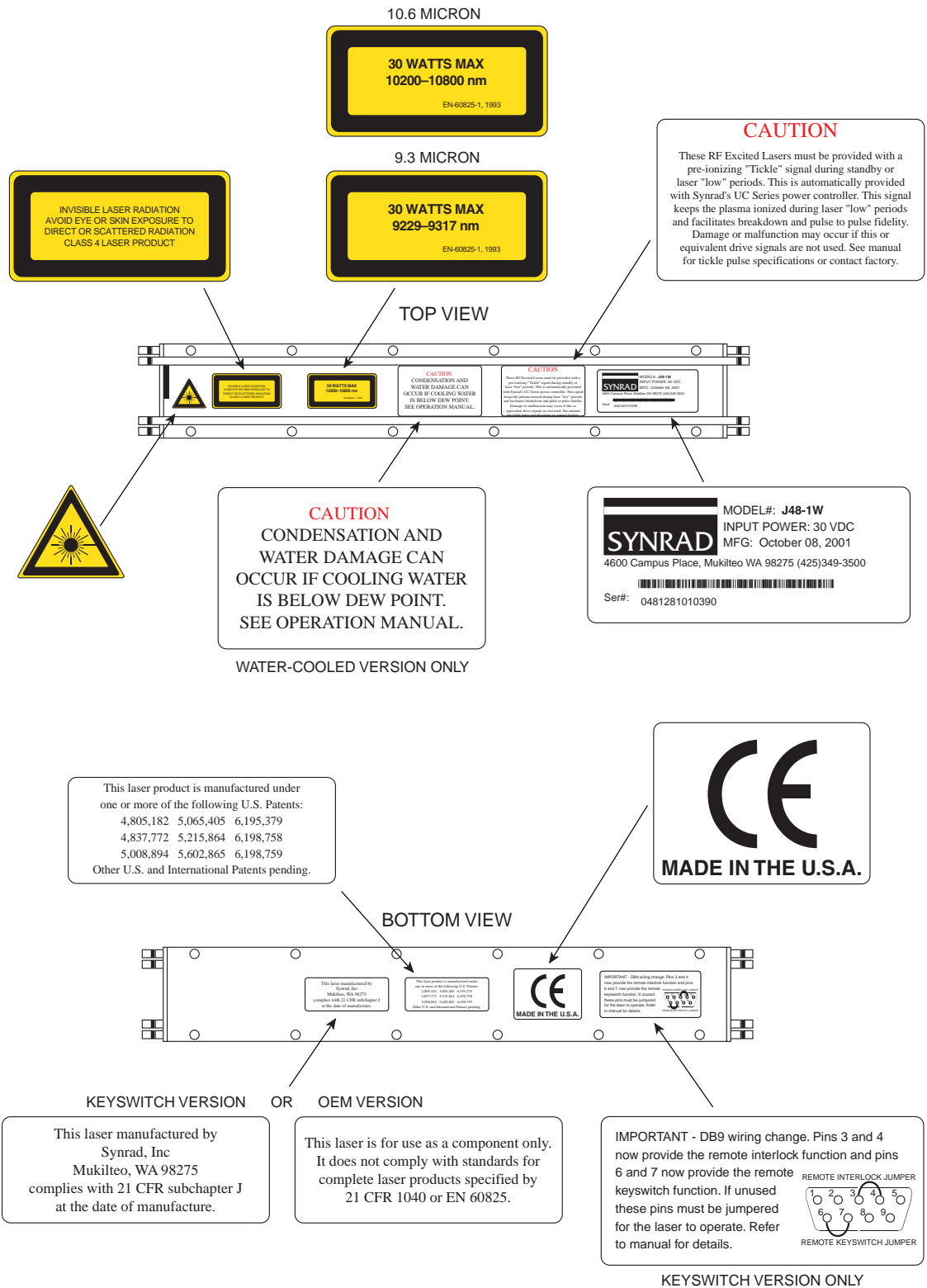

Figure 1 48-1 hazard label and CE label locations

laser safety

48-2 label locations

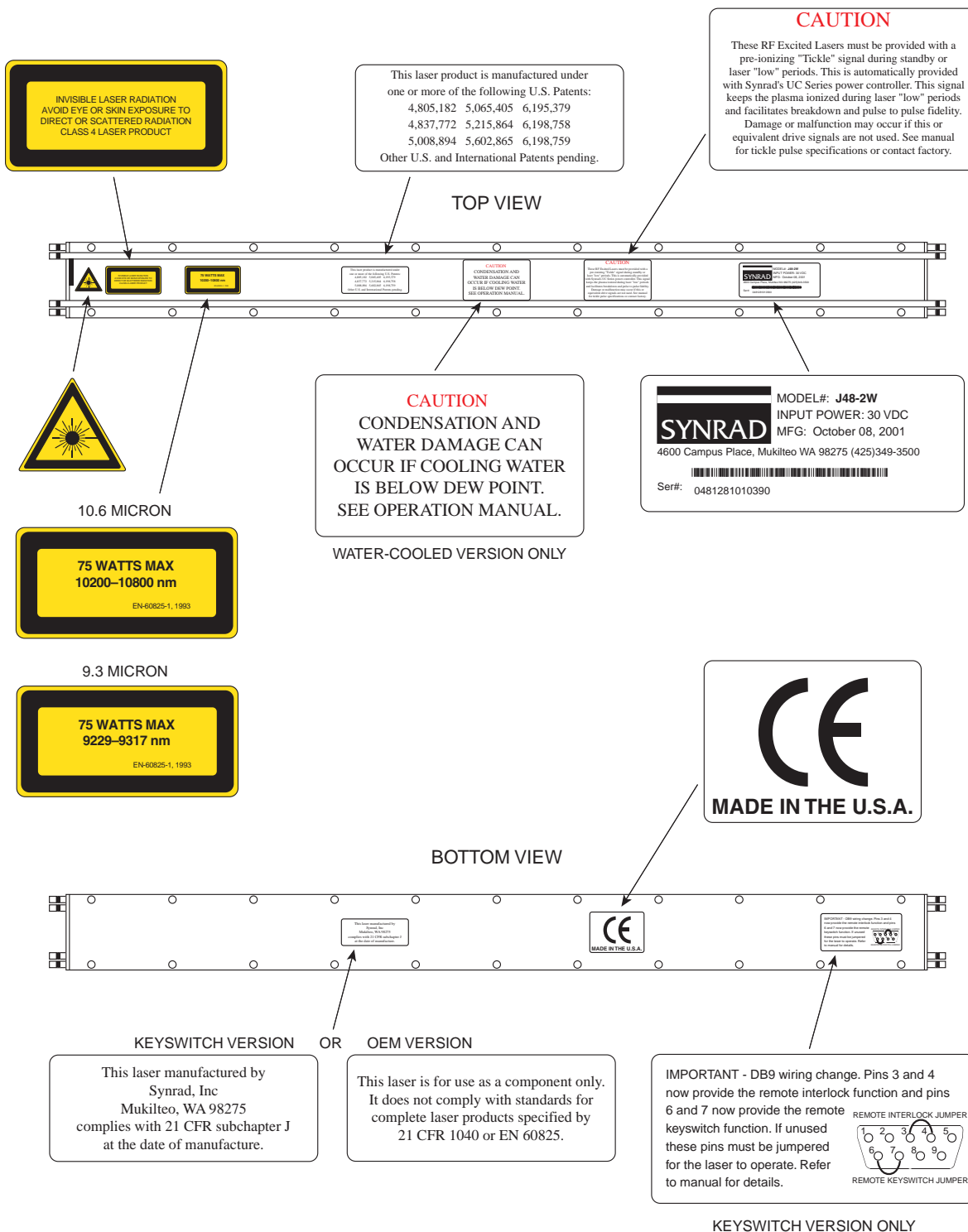

Figure 2 48-2 hazard label and CE label locations

laser safety

48-5 label locations

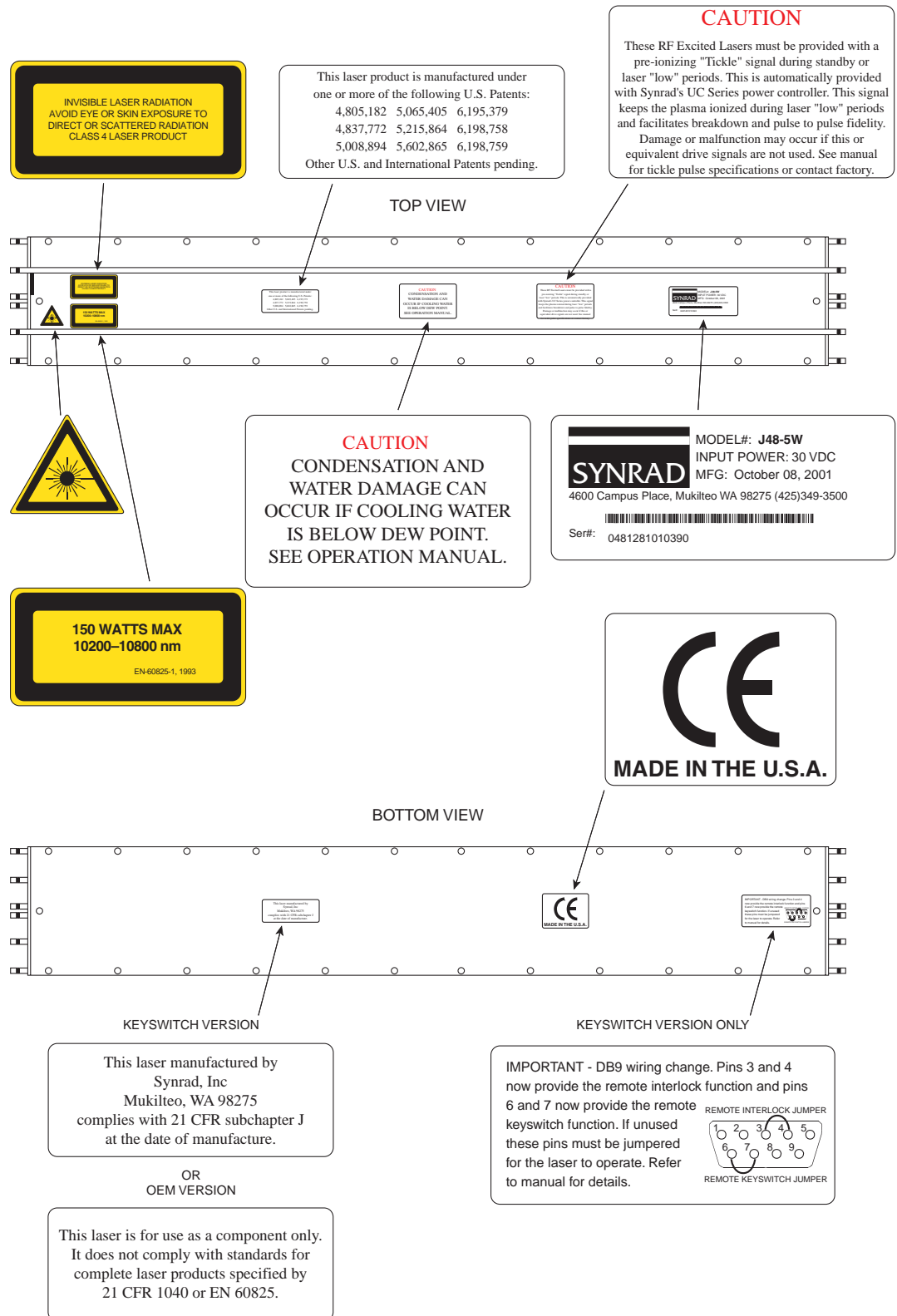

Figure 3 48-5 hazard label and CE label locations

laser safety

Agency compliance

The *Agency compliance* section includes subsections:

- Center for Devices and Radiological Health (CDRH) requirements
- Federal Communications Commission (FCC) requirements
- European Union (EU) requirements

Series 48 lasers are designed to comply with certain United States (U.S.) and European Union (EU) Directives. These Directives impose product performance requirements related to electromagnetic compatibility (EMC) and product safety characteristics for industrial, scientific, and medical (ISM) equipment. The associated Directives and specific provisions to which systems containing Series 48 lasers must comply are identified and described in the following paragraphs.

Series 48 lasers should be installed and operated in manufacturing or laboratory facilities by trained personnel only. Due to the considerable risks and hazards associated with the installation and operational use of this apparatus with the incorporated laser, the manufacturer has provided appropriate product warning labels and instructions to the user regarding laser safety. SYNRAD, Inc. assumes no responsibility for the compliance of the system into which the Series 48 laser is integrated.

Center for Devices and Radiological Health (CDRH) requirements

Series 48 Keyswitch models comply with requirements for Class IV laser products imposed by the Radiation Control for Health and Safety Act of 1968. Under this Act, the U.S. Food and Drug Administration (FDA) issued a performance standard in the *Code of Federal Regulations* (CFR) for laser products. This performance standard (21 CFR, Subchapter J, Part 1040.10) was developed to protect public health and safety by imposing requirements upon manufacturers of laser products to provide an indication of the presence of laser radiation, to provide the user with certain means to control radiation, and to assure that personnel are adequately warned of potential hazards through the use of product labels and instructions.

Federal regulations require that all laser products manufactured on or after August 2, 1976 be certified as complying with the performance standard. The manufacturer must demonstrate the product's compliance with the standard prior to certification or introduction into commerce by furnishing to the Center for Devices and Radiological Health (CDRH) reports pertaining to the radiation safety of the product and the associated quality control program. Failure to provide the required reports or product certification is a violation of Section 360B of the Radiation Control for Health and Safety Act of 1968.

Product features incorporated into the design of Series 48 lasers to comply with CDRH requirements are integrated as panel controls or indicators, internal circuit elements, or input/output signal interfaces. Specifically, these features include a keyswitch (Keyswitch versions), laser and laser ready indicators, remote interlock for power on/off, a laser aperture shutter switch, and a five-second delay between power on and lasing. Incorporation of certain features is dependent on the laser version (Keyswitch or OEM). Product features are summarized in Table 1, *Class IV safety features*. The table indicates which features are available on Series 48 lasers, the type and description of the feature, and if the feature is required by, and complies with, CDRH regulations.

Series 48 OEM (-S) model lasers are OEM products intended for incorporation as components in a laser processing system and as such, do not comply with 21 CFR, Subchapter J without additional safeguards. These safeguards will vary depending on the type of system in which the laser will be incorporated. For instance, if the system is intended to be a Class I laser system, the OEM or System Integrator must provide guarding to prevent laser emission in excess of the Accessible Emission Limits (AEL) for Class I devices. For incorporation in a Class IV laser system, the integrated system must include a beam attenuator, a keyswitch, a remote interlock, and other safety features as described under the standard.

laser safety

Agency compliance

Safe operating practices per ANSI Z136.1-1993 should be exercised at all times when actively lasing. To prevent exposure to direct or scattered laser radiation, follow all safety precautions specified throughout this manual. The use of controls or adjustments or performance of procedures other than those specified herein may result in exposure to hazardous invisible laser radiation, damage to, or malfunction of the laser. Severe burns will result from exposure to the laser beam. Always wear safety glasses with side shields to reduce the risk of damage to the eyes when operating the laser.

Safe operation of the laser requires the use of an external beam block to safely block the beam from traveling beyond the desired work area. Use a firebrick or similar non-scattering, noncombustible material as the beam block. Never use organic material or metals as the beam blocker; organic materials, in general, are apt to combust or melt and metals act as specular reflectors which may create a hazard outside the immediate work area.

Federal Communications Commission (FCC) requirements

The United States Communication Act of 1934 vested the Federal Communications Commission (FCC) with the authority to regulate ISM equipment that emits electromagnetic radiation in the radio frequency spectrum. The purpose of the Communication Act was to prevent harmful electromagnetic interference (EMI) from affecting authorized radio communication services.

The FCC regulations that govern industrial, scientific, and medical (ISM) equipment are fully described in 47 CFR, Part 18, Subpart C. SYNRAD's Series 48 lasers have been tested and found to comply by demonstrating performance characteristics that have met or exceeded the requirements of 47 CFR, Part 18, Radiated and Conducted Emissions.

FCC information to the user

NOTE: The following FCC information to the user is provided to comply with the requirements of 47 CFR, Part 18, Section 213.

Interference Potential

In our testing, SYNRAD, Inc. has not discovered any significant electrical interference traceable to Series 48 lasers.

System Maintenance

Ensure that all exterior covers are properly fastened in position.

Measures to Correct Interference

If you suspect that your Series 48 laser interferes with other equipment, take the following steps to minimize this interference:

- 1 Use shielded cables to and from the equipment that is experiencing interference problems.
- 2 Ensure that the Series 48 laser is properly grounded to the same electrical potential as the equipment or system it is connected to.
- 3 Install bisected ferrite on the laser's DC power cables; locate them as close as possible to the laser housing.

laser safety

Agency compliance

FCC caution to the user

The FCC warns the user that changes or modifications of the unit not expressly approved by the party responsible for compliance could void the user's authority to operate the equipment.

European Union (EU) requirements

The European Norm (EN) document EN 60825-1 2003-06, *Safety of Laser Products*, was developed to protect persons from laser radiation by imposing requirements upon manufacturers of laser products to provide an indication of laser radiation; to classify laser products according to the degree of hazard; to require both user and manufacturer to establish procedures so that proper precautions are adopted; to ensure adequate warning of the hazards associated with accessible radiation through signs, labels, and instructions; to improve control of laser radiation through protective features; and to provide safe usage of laser products by specifying user control measures.

Series 48 Keyswitch models are designed to comply with the requirements imposed by EN 60825-1. Table 1, *Class IV safety features*, summarizes Series 48 product features, indicating the type and description of features and whether those features are required by European Union regulations.

Series 48 OEM (-S) model lasers are OEM products intended for incorporation as components in a laser processing system and as such, do not comply with EN 60825-1 without additional safeguards. OEM laser products which are sold to other manufacturers for use as components of any system for subsequent sale are not subject to this Standard, since the final product will itself be subject to the Standard.

The European Union's Electromagnetic Compatibility (EMC) Directive 89/336/EEC is the sole Directive developed to address electromagnetic interference (EMI) issues in electronic equipment. In particular, the Directive calls out European Norm (EN) documents that define the emission and immunity standards for specific product categories. For Series 48 lasers, the standard EN 55011 (CISPR:11) defines the radiated RF emissions limit. The standard EN 50082-1 defines generic immunity requirements published by the International Electromechanical Commission (IEC).

SYNRAD's Series 48 lasers have demonstrated performance characteristics that have met or exceeded the requirements of EMC Directive 89/336/EEC.

In accordance with Machinery Directive 89/392/EEC, Article 1, paragraph 4 and 5, the Machinery Directive does not apply to this device. In consideration of the incorporation of the Series 48 laser into devices that may fall under the definition of a "machine", SYNRAD, Inc. considers the application of the EMC Directive as sufficient evidence that the Series 48 laser will not compromise the compliance of the "machine" into which it is incorporated.

After a product has met the requirements of all applicable EU Directives, the product can bear the official compliance mark of the European Union as shown in Figure 4.



MADE IN THE U.S.A.

Figure 4 European compliance mark

laser safety

Agency compliance

Table 1 Class IV safety features

Feature	Location/Description	Required by:	
		CDRH	EN60825-1
Keyswitch ¹	Panel control On/Off Keyswitch controls power to laser electronics. Key can not be removed from switch in the “On” position.	Yes	Yes
Shutter function ¹	Laser control Attenuates beam / disables RF driver/laser output when closed.	Yes	Yes
Power ² indicator	Panel indicator (Green) Indicates that laser has power applied and is capable of lasing.	Yes	No
Lase indicator	Panel indicator (Red) Indicates laser is actively lasing. Illuminates when duty cycle of Command signal is long enough to produce laser output.	Yes	Yes
Five-second delay	Circuit element Disables RF driver/laser output for five to ten seconds after Key-switch is turned to “On” and remote keyswitch is closed.	Yes	No
Power-on reset	Circuit element Disables RF driver/laser output if input power is removed then later reapplied (AC power failure) while Keyswitch is in “On” position.	Yes	No
Remote Interlock ¹	Panel connection Disables RF driver/laser output when remote interlock switch on equipment door or panel is opened.	Yes	Yes
Remote Keyswitch	Panel connection Allows operator to turn laser On/Off from a remote location.	No	No
Over/under voltage protection	Circuit element Fault shutdown occurs if supply voltage falls below +15 V or rises above +36 V. Reset laser to restore operation.	No	No
Reverse voltage protection	Circuit element Internal diode protects circuitry from reverse input voltages. External fuse will blow.	No	No
Overtemp protection	Circuit element Over temperature shutdown occurs when temperature of tube reaches 60 °C ±2 °C. Reset laser to restore operation.	No	No
PWM failure protection	Circuit element Disables laser if output power exceeds Command input by 20% or more due to electronics failure. Reset laser to restore operation.	No	No
Fault signal	Signal output Latches to a logic low state when a fault shutdown occurs.	No	No
Message signal	Signal output Pre-shutdown warning latches to a logic low state when tube temperature reaches 54 °C ±2 °C.	No	No
Warning labels	Exterior housing Labels attached to various locations to warn of potential hazards.	Yes	Yes

¹ Keyswitch version only

² On OEM versions, the Power indicator illuminates and the five-second delay begins when DC power is applied to the laser

laser safety

Declaration of Conformity

Declaration Of Conformity

Applicable EU Directive(s): 89/336/EEC EMC Directive

Applicable Standards/Norms: EN 55011 Radiated, Class A, Group 2
EN 60825-1 Laser Safety
EN 50082-1 Generic Immunity
IEC 801-2 Electrostatic Discharge
IEC 801-3 RF Radiated
IEC 801-4 Fast Transients

Manufacturer: SYNRAD, Inc.
4600 Campus Place
Mukilteo, WA 98275

Model Number:	Serial Number (Compliant Unit)	Date Of Compliance
J48-1		29 October 1998
J48-2		29 October 1998
J48-5	J48-5S-2197	29 October 1998

We, SYNRAD, Inc., hereby declare under our sole responsibility that the equipment specified above conforms to the above Directive(s) and Standard(s).

Corporate Officer:



Dave Clarke, President of SYNRAD

29 October 1998

Date

European Contact:

Excel Technology Europe GmbH
Münchner Str. 2a
D-82152 Planegg
Germany

getting started

Use information in this section to prepare your Series 48 laser for operation. The order of information presented in this section is the same as the order of tasks that you need to perform. The best way to get your laser ready for operation is to start at *Unpacking* and work your way through *Connecting*.

This section contains the following information:

- Introduction – introduces Series 48 lasers and lists important features.
- Unpacking – provides important information about shipping your Series 48 laser.
- Inventory – displays and describes all components shipped with your laser.
- Mounting – describes how to attach laser components to a mounting surface.
- Connecting – explains how to connect power and control cables as well as cooling connections for water-cooled models.

getting started

Introduction

Thank you for purchasing a Series 48 laser from SYNRAD, Inc. The Series 48 family of lasers incorporates the latest developments in sealed carbon dioxide devices, combining the best features of both waveguide and free space CO₂ laser technology in an innovative aluminum tube design. J Series lasers utilize state-of-the-art surface mount electronics, newly patented RF excitation technology, and fully CE-compliant systems for EMI containment, heat removal, and laser safety. In the 10 W to 50 W range of continuous optical output, these lasers represent an ideal balance between proven, mature laser tube technology and reliable, simplified electronic control.

Series 48 features include:

- Compact resonator design
- RF power supply integrated into laser chassis
- Keyswitch air- or water-cooled models available
- OEM (no Keyswitch/no shutter) air- or water-cooled models available

Series 48 nomenclature

Series 48 lasers are divided into two distinct functional categories: Keyswitch and OEM models. In addition to a manual *Keyswitch*, all *Keyswitch*-equipped lasers include a manual *Shutter Switch* that allows the laser output aperture to be blocked. OEM lasers do not incorporate either a manual keyswitch or shutter assembly since they are designed as components for integration into a larger processing system by an Original Equipment Manufacturer (OEM) or System Integrator who bears the responsibility for meeting the appropriate laser safety requirements for Class IV laser systems.

Caution

serious
personal
injury

Please read this manual completely before using your laser. To prevent injury to personnel or damage to the laser, follow all safety precautions, handling, and setup instructions as described herein.

getting started

Unpacking

The *Unpacking* section includes subsections:

- Incoming inspection
- Packaging guidelines

Incoming inspection

Upon arrival, inspect all shipping containers for signs of damage. If you discover shipping damage, document the damage (photographically if possible), then immediately notify the shipping carrier and SYNRAD.

The shipping carrier is responsible for any damage occurring during transportation from SYNRAD, Inc. to your receiving dock.

Carefully remove your Series 48 laser from the shipping container and remove the outer foam packing material. Inspect the laser housing for any signs of shipping damage. Verify that all external labels are attached to the housing (refer to label location drawings in the “Laser Safety” section). Contact SYNRAD Customer Service if the laser housing is damaged or if any of the required accessory materials or labels are missing.

Packaging guidelines

- To prevent equipment damage or loss of small components, use care when removing packaging materials.
- Save all shipping containers and packaging materials, including covers and plugs. Use these specialized packing materials when shipping the laser to another location.
- After unpacking, review the *Inventory* section and verify that all components are on hand.
- When packing a laser for shipment, be sure to remove all accessory items not originally attached to the laser including beam delivery components, cooling tubing, fittings, etc.
- When shipping water-cooled lasers, remember to drain all cooling water from the laser and then cap the open fittings to prevent debris from entering the coolant path.
- Do not lift or support the laser using the cooling fittings; lift the laser by the mounting feet or baseplate only.

getting started

Inventory

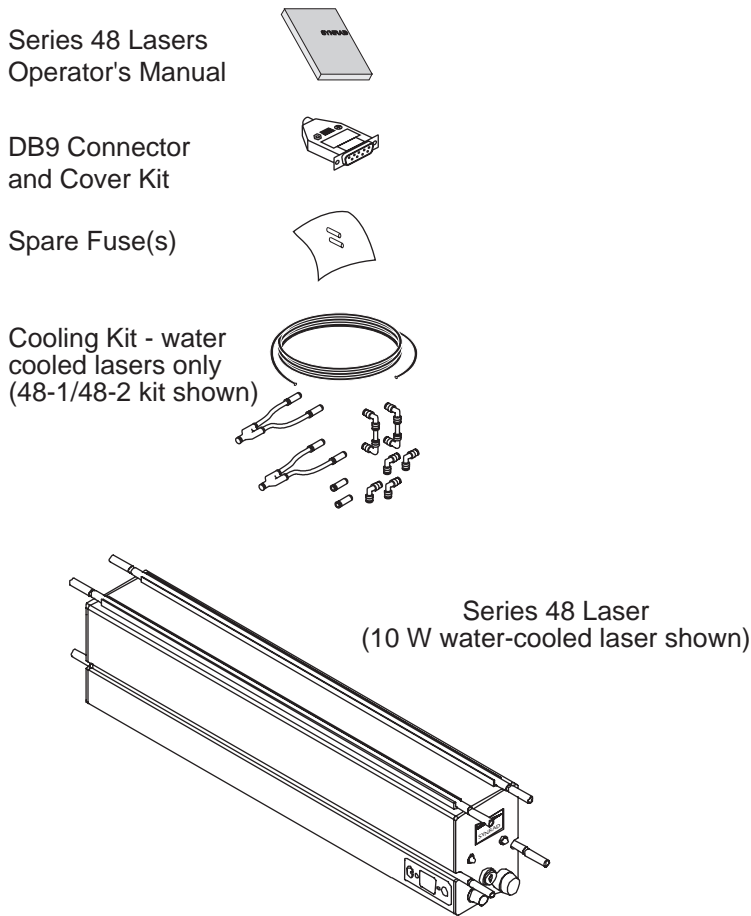

Figure 1-1 Series 48 shipping box contents

Table 1-1 lists items included in the Series 48 ship kit.

Table 1-1 Ship kit contents

Shipping Box Contents	Qty
SYNRAD Series 48 Laser	1
Series J48 Lasers Operator's Manual	1
DB9 Connector and Cover Kit.....	1
Spare Fuse(s)	1
Cooling Kit (water-cooled lasers only)	1
Final Test Report (not shown)	1

getting started

Inventory

Contents description

Each item listed in Table 1-1 is described below.

SYNRAD Series 48 Laser – for cutting, welding, drilling, and marking a wide variety of products and materials.

Series 48 Lasers Operator's Manual – provides setup, operation, and maintenance information for your Synrad Series 48 laser.

DB9 Connector and Cover Kit – connects to the Series 48 *DB9 Connector*. Use this connector to replace the factory jumper plug when integrating Series 48 laser signals into your control system.

Spare Fuse(s) – fast-blow fuse protects Series 48 internal circuitry. A 10 A fuse is included with 48-1 lasers, a 20 A fuse with 48-2 lasers, and two 20 A fuses are shipped with 48-5 lasers.

Cooling Kit (water-cooled lasers only)

(48-1/48-2) – includes quick-disconnect inlet and outlet cooling manifolds, extra 1/4" union elbows, extra straight 1/8" NPT to 1/4" tube fittings, and 20 feet of 1/4 inch O.D. black polyethylene tubing.

(48-5) – includes quick-disconnect inlet and outlet cooling manifolds, extra 1/4" union elbows, extra straight 1/4" NPT to 3/8" tube fittings, and 20 feet of 3/8 inch O.D. black polyethylene tubing.

Final Test Report (not shown) – contains data collected during the laser's final pre-shipment test.

getting started

Mounting

The *Mounting* section includes subsections:

- Standard mounting
- With an FH Series marking head

The recommended mounting orientation for Series 48 lasers is horizontal. If this cannot be accomplished then the laser may be mounted at an angle of $> 20^\circ$ to the vertical. Consult the factory for limitations if the laser is mounted in a vertical orientation.

Note: To allow for proper airflow, air-cooled units must have at least 2.25" of unobstructed clearance between the outside edge of the cooling fan housing and any enclosure or mounting surface.

Standard mounting

Series 48 lasers may be hard-mounted to equipment by removing several of the bottom panel screws and replacing these with longer screws to secure the laser to optical assemblies. This mounting method is only recommended as long as the screws do not support the weight of the laser. For a sturdier attachment, the laser may be clamped to optical assemblies by applying clamping forces between top and bottom cover screws. Do not apply clamping forces on the longitudinal centerline.

- 1 Refer to the appropriate outline and mounting diagram in the "Technical Reference" section for mounting screw locations and then drill four (48-1) or six (48-2/48-5) holes into your mounting surface. Locate holes in a symmetrical pattern to properly distribute mounting forces.

Note: Do not remove covers from the laser housing when mounting.

- 2 Place your Series 48 laser on the mounting surface so that the threaded holes on the laser housing line up with the holes drilled through the mounting surface.
- 3 Measure the 6-32 screws (48-1/48-2) or 10-32 screws (48-5) you removed from the laser housing and add a length equivalent to the thickness of the mounting surface.
- 4 Insert these new screws through the mounting surface into the threaded holes of the laser housing. Turn the screws by hand until the threads engage and then tighten using an Allen wrench.

With an FH Series marking head

To mount your Series 48 laser to an FH Series marking head, perform the following steps:

Note: The laser's mounting feet are precisely aligned and shimmed at the factory to ensure alignment between the marking head and the *Mounting Rail*. Do not loosen or remove the mounting feet from the laser. See the *FH Series Marking Head Operator's Manual* for further details.

- 1 Orient the laser on the FH *Mounting Rail* with the laser's output aperture facing the *L-bracket*.
- 2 Ease the laser forward until the dowel pins on the mounting feet drop into the dowel pin holes in the *Mounting Rail*. The screw holes on the ends of the mounting feet should be positioned over the appropriate mounting holes in the *Mounting Rail*.
- 3 Install and tighten four capscrews to secure the laser to the *Mounting Rail*. 48-1 and 48-2 lasers use 6-32 \times 1" socket head capscrews while 48-5 lasers use 10-32 \times 3/4" fasteners.

getting started

Connecting

The *Connecting* section includes subsections:

- Air-cooled connections
- Water-cooled connections
- Electrical connections
- Control connections
- DB9 connections

The *Connecting* section contains all the information you need to connect your Series 48 laser for operation. Figure 1-7 at the end of this chapter illustrates the connections used in a typical Series 48 laser system.

Air-cooled connections

Note: 48-5 (50 W) lasers must be water-cooled to prevent damage to the laser. See the *Water-cooled connections* section for connection details.

Since air-cooled lasers are shipped without cooling fans, customers must provide air cooling to prevent overheating of the laser. An airflow of 250 cubic feet per minute (CFM) per fan is required to keep laser and heatsink temperatures below 50 °C. 48-1 lasers have a heat load specification of 300 W maximum and requires two cooling fans for a total of 500 CFM. 48-2 lasers have a 500 W heat load and requires four cooling fans for a total air flow of 1000 CFM.

Place cooling fans symmetrically on each side of the laser so that air flow is directed perpendicular to the laser's cooling fins as shown in Figure 1-2. The fans should have a diameter of approximately 4.5" to 5" and have at least 2.25" of unobstructed clearance between the outside edge of the cooling fan housing and any enclosure or mounting surface.

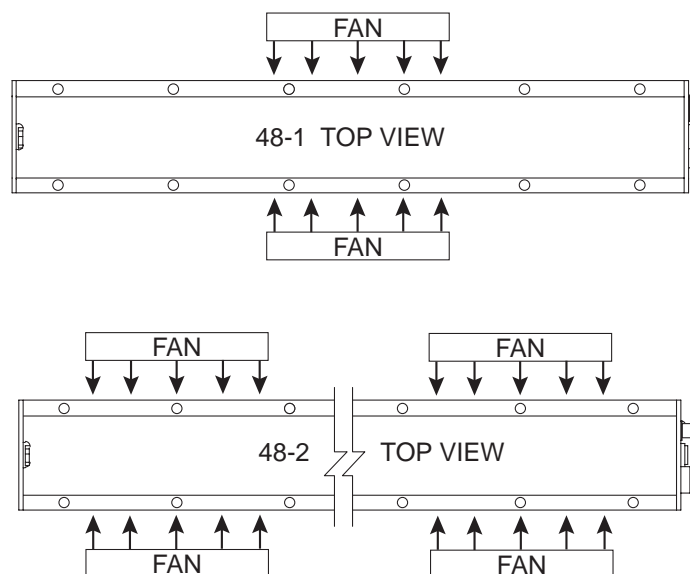

Figure 1-2 48-1 / 48-2 cooling fan placement

getting started

Connecting

Water-cooled connections

Read *Guidelines for cutting and installing tubing* before installing any cooling tubing and then make sure to connect the cooling system exactly as described for your particular laser.

Guidelines for cutting and installing tubing

- Cut tubing lengths generously to allow for trimming.
- Cut tubing squarely; diagonal cuts may not seal properly. Trim away any burrs if the cut is “ragged”.
- Avoid excessive stress on fittings by creating a gentle radius when bends in the tubing are close to fittings. Bending tubing too sharply will compromise the sealing properties of the fitting.
- Never allow the tubing to kink, since kinking severely restricts coolant flow.
- Push tubing completely into the fitting, then pull the tubing to verify that it is locked into place. Tubing extends into the fitting approximately 7/8 of an inch.
- If tubing must be disconnected from a fitting, first push and hold the tubing slightly into the fitting. Next push the white fitting ring evenly towards the fitting, and then pull the tubing free.
- After disconnecting tubing from a fitting, trim 1/2 inch from its end before reconnecting. Trimming the end of the tubing before reconnecting the fitting provides an undisturbed sealing surface.

Laser cooling fittings

If your integrated laser application uses metric cooling tubing, we recommend the installation of tubing adaptors to convert 48-1/48-2 cooling kit fittings from 1/4 inch tubing to 6 mm metric tubing. For 48-5 cooling kits, convert the 3/8 inch tubing to 8 mm metric tubing. These tubing adaptors are available from many tubing and fitting manufacturers.

Setting coolant temperature

Note: SYNRAD recommends that the laser’s cooling fluid contain no less than 90% water by volume. In applications where biocides containing chlorides are used, concentrations should not exceed 25 parts per million (PPM).

Choosing the correct coolant temperature is important to the proper operation and longevity of your laser. When coolant temperature is lower than the dew point (the temperature at which moisture condenses out of the surrounding air), condensation forms inside the laser housing leading to failure of laser electronics as well as damage to optical surfaces.

Caution

possible
equipment
damage

Operating the laser at coolant temperatures above 22 °C (72 °F) may result in decreased performance and/or premature failure of electronic components.

getting started

Connecting

The greatest risk of condensation damage occurs when water-cooled lasers are run in a high heat/high humidity environment and the chiller's coolant temperature is colder than the dew point of the surrounding air or when the system is shut down, but coolant continues to flow through the laser for extended periods of time.

The chiller's temperature setpoint must always be set above the dew point temperature. In cases where this is not possible within the specified coolant temperature range of 18 °C to 22 °C (64 °F to 72 °F), then the following steps **MUST** be taken to reduce the risk of condensation damage.

- Stop coolant flow when the laser is shut down.
- Increase coolant flow by an additional 1.0 GPM. Do not exceed a coolant pressure of 60 PSI.
- Air-condition the room or the enclosure containing the laser.
- Install a dehumidifier to reduce the humidity of the enclosure containing the laser.

Table 1-2 provides dew point temperatures for a range of air temperature and relative humidity values. Remember that the laser's coolant temperature must be set above the dew point temperatures shown in the chart, but should not exceed 22 °C (72 °F).

Table 1-2 Dew point temperatures

Dew Point Temperature Chart °F (°C)

Air Temp °F (°C)	Relative Humidity (%)															
	20	25	30	35	40	45	50	55	60	65	70	75	80	85	90	95
60 (16)	—	—	—	32 (0)	36 (2)	39 (4)	41 (5)	44 (7)	46 (8)	48 (9)	50 (10)	52 (11)	54 (12)	55 (13)	57 (14)	59 (15)
65 (18)	—	—	33 (1)	37 (3)	40 (4)	43 (6)	46 (8)	48 (9)	51 (11)	53 (12)	55 (13)	57 (14)	59 (15)	60 (16)	62 (17)	64 (18)
70 (21)	—	33 (1)	37 (3)	41 (5)	45 (7)	48 (9)	51 (11)	53 (12)	56 (13)	58 (14)	60 (16)	62 (17)	64 (18)	65 (18)	67 (19)	69 (21)
75 (24)	—	37 (3)	42 (6)	46 (8)	49 (9)	52 (11)	55 (13)	58 (14)	60 (16)	62 (17)	65 (18)	67 (19)	68 (20)	70 (21)	72 (22)	73 (23)
80 (27)	35 (2)	41 (5)	46 (8)	50 (10)	54 (12)	57 (14)	60 (16)	62 (17)	65 (18)	67 (19)	69 (21)	71 (22)	73 (23)	75 (24)	77 (25)	78 (26)
85 (29)	40 (4)	45 (7)	50 (10)	54 (12)	58 (14)	61 (16)	64 (18)	67 (19)	70 (21)	72 (22)	74 (23)	76 (24)	78 (26)	80 (27)	82 (28)	83 (28)
90 (32)	44 (7)	50 (10)	54 (12)	59 (15)	62 (17)	66 (19)	69 (21)	72 (22)	74 (23)	77 (25)	79 (26)	81 (27)	83 (28)	85 (29)	87 (31)	88 (31)
95 (35)	48 (9)	54 (12)	59 (15)	63 (17)	67 (19)	70 (21)	73 (23)	76 (24)	79 (26)	81 (27)	84 (29)	86 (30)	88 (31)	90 (32)	92 (33)	93 (34)
100 (38)	52 (11)	58 (14)	63 (17)	68 (20)	71 (22)	75 (24)	78 (26)	81 (27)	84 (29)	86 (30)	88 (31)	91 (33)	93 (34)	95 (35)	97 (36)	98 (37)

getting started

Connecting

48-1 / 48-2 cooling tubing connections

Water enters at the laser's rear plate through the lower side-mounted 1/4 inch diameter cooling tubes and exits through the top-mounted cooling tubes. Both circuits must be used in parallel to maintain thermal balance. The two right angle connections are installed on the front plate. The cooling kit also includes quantities of both straight and elbow fittings; you can order other compatible fittings from your local fitting supply house. All fittings are quick-disconnect types.

To connect cooling tubing to your 48-1 or 48-2 water-cooled laser, refer to Figure 1-3 and perform the following steps:

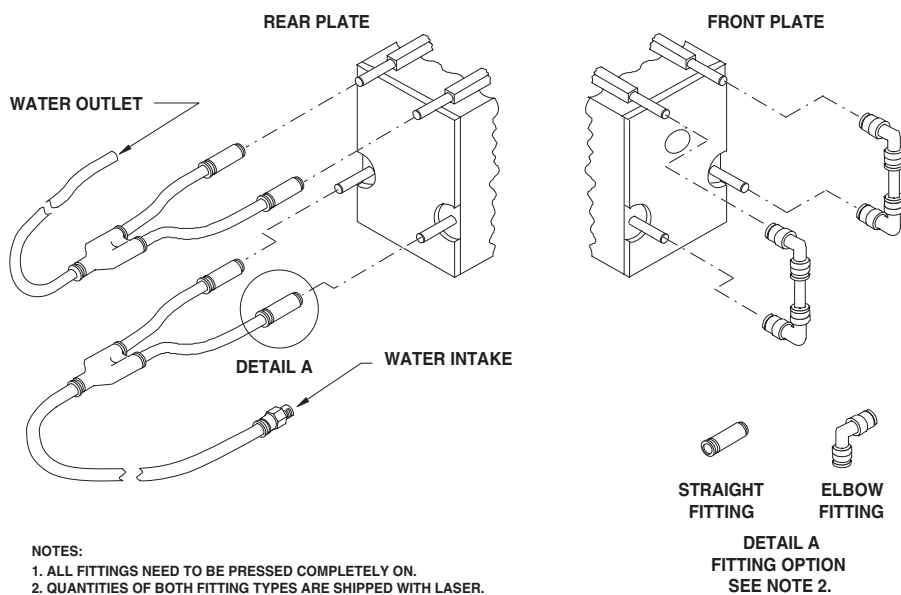

Figure 1-3 48-1 / 48-2 cooling connections

- 1 Connect the Water Intake manifold to both of the laser's lower coolant tubes on the rear plate.
- 2 Connect the Water Intake fitting to your coolant source.
- 3 Connect the Water Outlet manifold to both of the laser's upper coolant tubes on the rear plate.
- 4 Connect the Water Outlet fitting to your coolant return or drain.
- 5 On the front plate, connect one right angle connection between one of the lower coolant tubes and its corresponding upper coolant tube. Repeat this step on the other set of lower/upper tubes.

Caution

possible
equipment
damage

Inlet cooling water temperature must always be maintained above the dew point to prevent condensation and water damage to your laser.

getting started

Connecting

- 6 Turn on the chiller and adjust the temperature setpoint to 18 °C to 22 °C. Regulate coolant flow to 0.5 GPM (48-1) or 0.8 GPM (48-2) at less than 60 PSI of pressure.
- 7 Closely examine all cooling connections and verify that there are no leaks.

48-5 cooling tubing connections

Cooling water enters the laser through the two lower side-mounted tubes plus one of the center-mounted cooling tubes located on the laser's rear plate. Cooling water flows through the tubes and out the two top-mounted cooling tubes and the other center-mounted tube. The front central tubes are "jumpared" using a "U" fitting while the front side and top connections on the front plate are also jumpared using two right angle connections. The cooling kit also includes quantities of both straight and elbow fittings; you can order other compatible fittings from your local fitting supply house. All fittings are quick-disconnect types.

To connect cooling tubing to your 48-5 laser, refer to Figure 1-4 and perform the following steps:

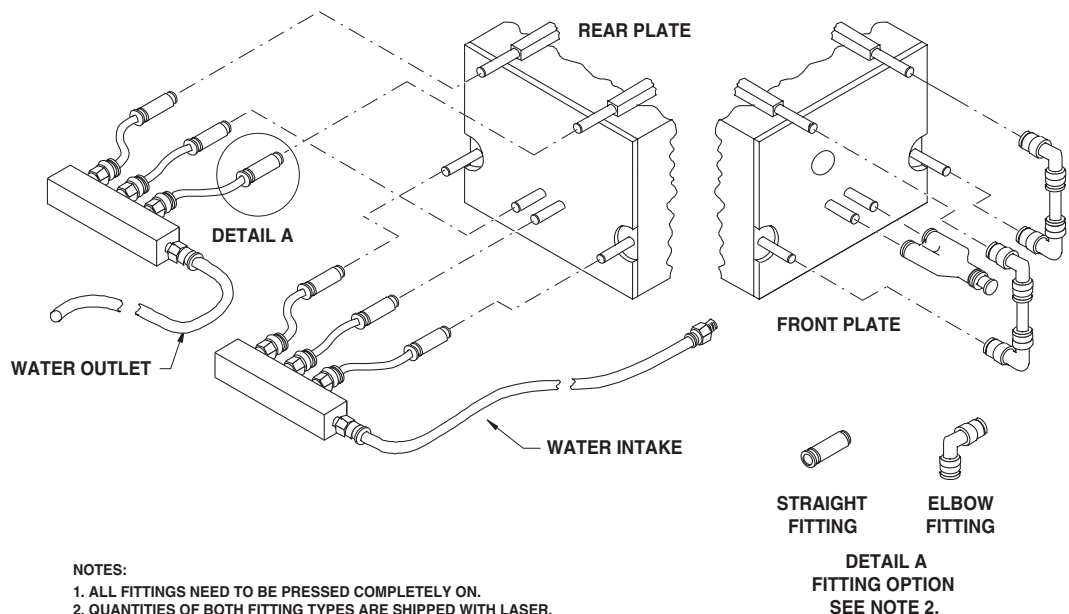

Figure 1-4 48-5 cooling connections

- 1 Connect the Water Intake manifold tubing to both of the laser's lower side-mounted coolant tubes and one of the center coolant tubes on the rear plate.
- 2 Connect the Water Intake fitting to your coolant source.
- 3 Connect the Water Outlet manifold tubing to both of the laser's upper coolant tubes and one of the center coolant tubes on the rear plate.
- 4 Connect the Water Outlet fitting to your coolant return or drain.
- 5 On the front plate, connect one right angle connection between one of the lower coolant tubes and its corresponding upper coolant tube. Repeat this step on the other set of lower/upper tubes.
- 6 Connect the "U" connector between both of the center coolant tubes.

getting started

Connecting

Caution

possible
equipment
damage

Inlet cooling water temperature must always be maintained above the dew point to prevent condensation and water damage to your laser.

- 7 Turn on the chiller and adjust the temperature setpoint to 18 °C to 22 °C. Regulate coolant flow to 1.5 GPM at less than 60 PSI of pressure.
- 8 Closely examine all cooling connections and verify that there are no leaks.

Electrical connections

DC power supply

SYNRAD power supplies, models DC-1, DC-2, and DC-5, are sized to power 48-1, 48-2, and 48-5 lasers respectively. The 48-1 laser requires a SYNRAD DC-1 or equivalent power supply capable of providing 30 VDC at 7 A maximum; the 48-2 laser requires a SYNRAD DC-2 power supply (30 VDC at 14 A max.); and the 48-5 requires a SYNRAD DC-5 power supply (30 VDC at 28 A max.).

If substituting power supplies, use a well-regulated DC power supply in the range of 30 V to 32 V with no more than 3 V overshoot under a 10–90% modulation load. The use of short leads and terminations rated for the appropriate output current is recommended.

Note: SYNRAD lasers are tested to meet published specifications at an input voltage of 30 VDC.

AC input power requirements for the DC-1 power supply are 85–264 VAC, single phase (1Ø), 20 A max, 47–440 Hz. Input requirements for both DC-2 and DC-5 supplies are 90–132 VAC (low range) or 175–264 VAC (high range), single phase (1Ø), 13 A (DC-2) or 25 A (DC-5) max, 47–440 Hz.

DC-1 power supply

To connect the DC-1 power supply, refer to Figure 1-5 and perform the following steps:

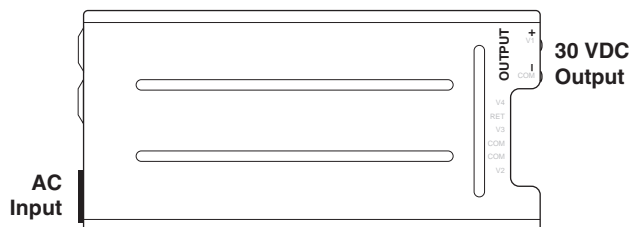

Figure 1-5 DC-1 (Astec) power supply

getting started

Connecting

- 1 Verify that input AC to the DC power supply is physically locked out or disconnected.
- 2 Locate the 30 VDC output terminals on the power supply's output section and connect the black (-) DC Power cable from the laser to the negative (- COM) output terminal.
- 3 Connect the red (+) DC Power cable from the laser to the positive (+ V1) 30 VDC output terminal.
- 4 Connect the AC line cord to the AC receptacle located on the fan end of the DC-1 power supply.

Note: U.S., European, and UK line cords are available for the DC-1 power supply. If the line cord provided does not fit your available AC outlet, you will need to provide a cable with the proper AC outlet plug on one end and a standard IEC 320 female connector on the power supply end.

DC-2 / DC-5 power supply

To connect either the DC-2 or DC-5 power supply for 120 VAC (low range) input, refer to Figure 1-6 and follow the steps listed in the 120 VAC *input operation* section. If you are connecting the DC-2/DC-5 power supply for 240 VAC (high range) input, refer to Figure 1-6 and follow the steps listed in the 240 VAC *input operation* section.

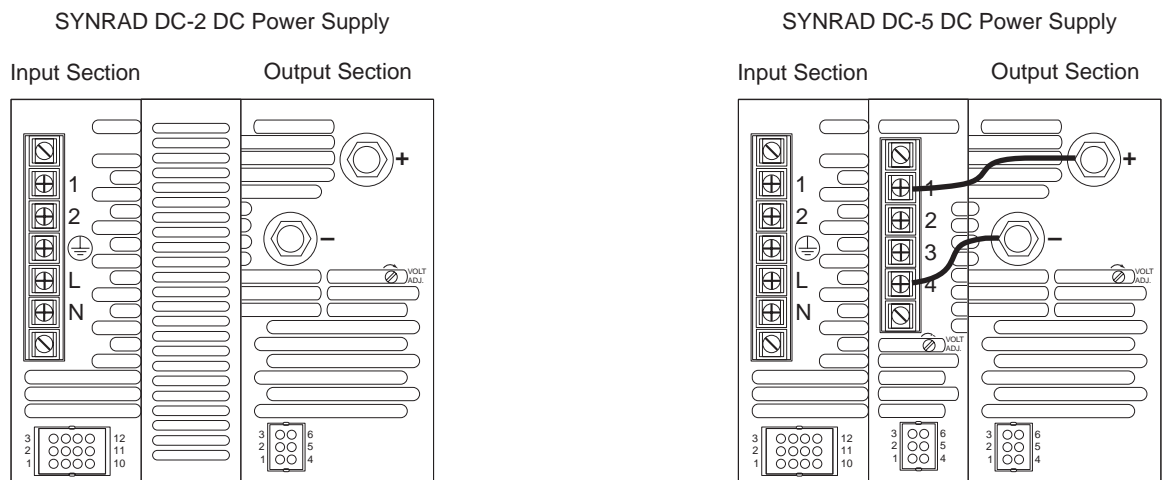

Figure 1-6 DC-2/DC-5 (Power-One) power supplies

120 VAC input operation

- 1 Verify that input AC power to the DC power supply is physically locked out or disconnected.
- 2 Locate the 30 VDC output terminals on the power supply's output section and connect the black (-) DC Power cable from the laser to the negative (-) output terminal.
- 3 Connect the red (+) DC Power cable from the laser to the positive (+) 30 VDC output terminal.
- 4 Locate the 5-pin terminal strip on the power supply's input section, under the protective snap-on cover.
- 5 Connect a jumper wire (16 AWG or heavier) between terminals 1 and 2.

getting started

Connecting

- 6 Connect the AC hot wire, typically black, from your 120 VAC source to the terminal labeled “L” (AC Line).
- 7 Connect the neutral wire, typically white, from your voltage source to terminal “N” (AC Neutral).
- 8 Connect the ground (earth) wire, typically green, from your AC voltage source to the terminal labeled with the ground symbol.

240 VAC input operation

- 1 Verify that input AC power to the DC power supply is physically locked out or disconnected.
- 2 Locate the 30 VDC output terminals on the power supply’s output section and connect the black (–) DC Power cable from the laser to the negative (–) output terminal.
- 3 Connect the red (+) DC Power cable from the laser to the positive (+) 30 VDC output terminal.
- 4 Locate the 5-pin terminal strip on the power supply’s input section, under the protective snap-on cover.
- 5 Connect one of the two AC hot wires, typically black, from your 240 VAC source to the terminal labeled “L” (AC Line).
- 6 Connect the other hot wire, typically black or red, from your voltage source to terminal “N” (AC Neutral).
- 7 Connect the ground (earth) wire, typically green, from your AC voltage source to the terminal labeled with the ground symbol.

Control connections

Warning

serious
personal
injury

Always use shielded cable when connecting your PWM Command signal source to the laser’s CTRL connections. In electrically-noisy environments, long lengths of unshielded wire act like an antenna and may generate enough voltage to trigger uncommanded lasing.

UC-2000 Universal Laser Controller

The operation of Series 48 lasers requires an external controller that can provide the necessary tickle and pulse width modulated (PWM) Command signals. SYNRAD recommends the use of a UC-2000 Universal Laser Controller to generate the PWM signals that control the laser’s output power. The UC-2000 requires 15–50 VDC @ 35 mA, supplied from either its wall plug transformer or from the *Auxiliary Power* connector on the side of Series 48 lasers. Refer to the *UC-2000 Laser Controller Operator’s Manual* for information about UC-2000 operation.

To connect a UC-2000 Controller (not included with Series 48 lasers), perform the following steps:

- 1 Connect the mini-DIN connector on the end of the UC-2000 Controller’s *Power/Control* cable to the *Laser* connector on the rear panel of the UC-2000.

getting started

Connecting

- 2 Connect the miniature DC power plug on the UC-2000's *Power/Control* cable to the laser's side-mounted *Auxiliary Power* connector.

To use the UC-2000's wall plug transformer instead, connect the miniature DC power plug on the UC-2000's *Power/Control* cable to the miniature connector on the wall plug transformer cable

- 3 On 48-1 and 48-2 lasers, attach the BNC connector on the end of the UC-2000's *Power/Control* cable to the BNC connector labeled *CTRL* on the rear of the laser.

On 48-5 lasers, attach the long "leg" of the BNC "Y" control cable to the BNC connector on the UC-2000's *Power/Control* cable. Attach the short "legs" of the "Y" cable to the laser's *CTRL1* and *CTRL2* connectors located on the rear of the laser.

Note: When driving the laser from an FH Series marking head, connect the marking head's *Laser Control* cable between the *Laser Control* connector on the marking head and the *CTRL* connectors on the rear of the laser.

- 4 If your application uses external gating signals to command On/Off switching of the laser, attach a BNC cable between your gate signal source and the UC-2000's *Gate* connector.
- 5 If your application uses external analog voltage or current signals to control the PWM duty cycle of the laser, attach a BNC cable between your analog voltage or current source and the UC-2000's *ANV/ANC* connector.

Note: Series 48 lasers can also be controlled from an alternate user-supplied PWM Command signal source. Refer to *Controlling laser power* in the "Technical Reference" section for control signal descriptions.

DB9 connections

48 Series lasers are equipped with a female DB9 connector mounted to the sidewall of the laser. This connector provides the user with a convenient method for monitoring fault conditions (over-temperature, control/RF circuitry failure) and adds remote interlock, remote keyswitch (relay or switch), message output, and remote LED indicator capability. For a complete description of DB9 pin assignments and functions, see *DB9 connections* in the "Technical Reference" section.

A factory-installed jumper plug is attached to the *DB9 Connector* on each laser to enable normal operation. Two jumpers (see Figure 3-9) are wired to the plug. One jumper between pins 6 and 7 closes the *Remote Keyswitch* function, and the other jumper between pins 3 and 4 closes the *Remote Interlock*. If this jumper plug is removed, it is essential that pin 3 be jumpered to pin 4 (or pin 2) or be connected to external "remote interlock" circuitry in order to enable lasing.

Note: On lasers manufactured as OEM (-S) version lasers, i.e. without a keyswitch, the "remote interlock" function is bypassed internally. For OEM customers wishing to access the "remote interlock" feature via the *DB9 Connector*, please consult the factory for details.

getting started

Connecting

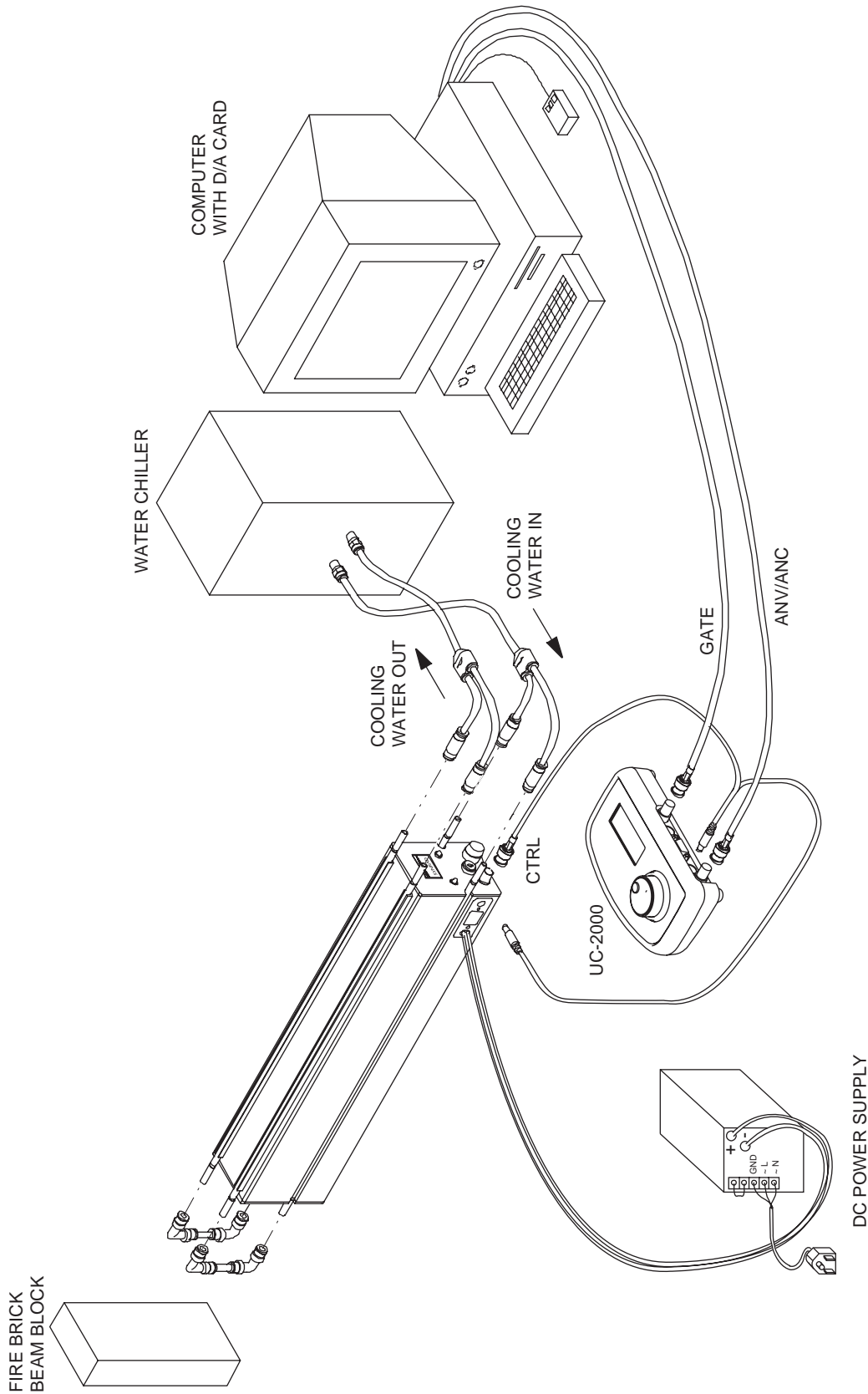

Figure 1-7 Typical Series 48 system interconnection diagram

operation

Use information in this section to familiarize yourself with Series 48 controls and indicators and to begin operating your laser.

This section contains the following information:

- Controls and indicators – displays and describes exterior controls and indicators on Series 48 Keyswitch and OEM lasers.
- Initial start-up – explains how to start your Series 48 laser while verifying proper operation.

operation

Controls and indicators

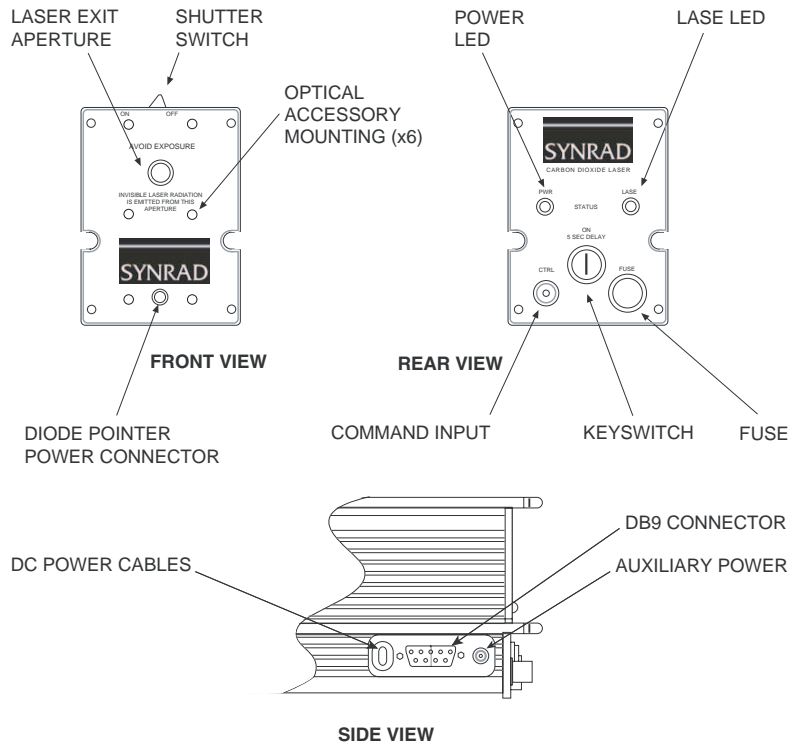

Figure 2-1 48-1 / 48-2 controls and indicators

Shutter Switch (Keyswitch models only) – The *Shutter Switch* is a mechanical shutter that closes the laser aperture and also actuates independent micro-switches that interrupt power to the laser section(s). The shutter should not be used to partially block the beam or to control output power.

Power LED – The *PWR LED* is a panel mounted LED that illuminates green when the *Keyswitch* is turned to the ON position (or when an OEM laser is powered up) to indicate that power is applied to internal circuitry.

Lase LED – The *LASE LED* is a panel mounted LED that illuminates red to indicate the lase mode of operation. If a tickle signal is present, the red LED turns on after the five-second delay and becomes brighter as the PWM Command duty cycle is increased.

Keyswitch (Keyswitch models only) – The panel-mounted *Keyswitch* is used to turn the laser on, off, and to reset faults. The key cannot be removed when the *Keyswitch* is in the ON position. For OEM lasers, a plug is installed in place of the *Keyswitch* and the keyswitch wires are shorted. The remote keyswitch pins of the *DB9 Connector* then become the external power on/off/reset control means.

Fuse – The panel-mounted fuse(s) provides overcurrent protection for the internal circuitry of the laser. The required fuse is a fast-blow type AGC/3AG rated at 32 V minimum with the following current ratings: 48-1 – 10 A; 48-2 – 20 A; 48-5 – 20 A (2 required)

DB9 Connector – The *DB9 Connector* is a 9-pin, female subminiature-D connector that provides an interconnection for message, fault shutdown, remote interlock, remote keyswitch, and interface signals. Refer to *DB9 connections* in the “Getting Started” section for connection information.

Command (CTRL) Input – The *CTRL* connector is a BNC-style jack that accepts tickle and PWM Command signal inputs. The output of the UC-2000 Controller (or FH Series marking head) is attached to this connector. For pure CW operation, a steady +5 V signal can be applied through this

operation

Controls and indicators

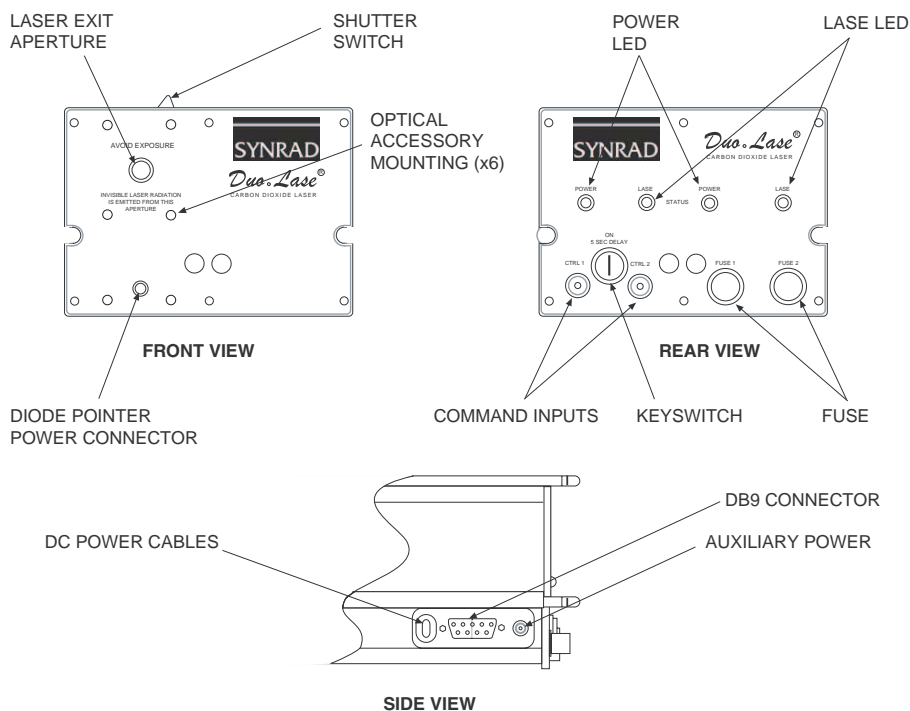

Figure 2-2 48-5 controls and indicators

connector (a tickle signal must be applied during laser-off periods). This input is optically-isolated from the chassis and power supply ground circuit but must not be subjected to common mode voltages greater than ± 50 VDC from chassis ground. The 48-5 laser has two Command inputs, *CTRL1* and *CTRL2*, that should always be driven identically from the signal source by using a “Y” cable or “T” BNC connector.

DC Power Cables – The red (+) and black (–) *DC Power* input cables provide +30 VDC operating power to the laser. Standard length is 60 inches.

Auxiliary Power Connector – The *Auxiliary Power* connector is installed in the side panel of the laser housing and provides an optional 30 VDC @ 350 mA source for powering the UC-2000 Controller. An auto-resetting solid-state fuse limits line current. Connector power is active after 30 VDC is applied to the laser.

Laser Exit Aperture – The aperture provides an opening from which the beam is emitted when lasing.

Diode Pointer Power Connector (optional) – The *Diode Pointer Power* connector is not installed unless a Diode Pointer is ordered when the laser is built. This connector provides a regulated +5 VDC, 100 mA output for the optional Diode Pointer, available from SYNRAD. The Diode Pointer connector is internally protected against short circuits by an auto-resetting, solid-state fuse.

Optical Accessory Mounting – The front faceplates of Series 48 lasers are designed with a 6-hole mounting pattern (refer to the Outline/Mounting diagrams in the “Technical reference” section) to provide a convenient method for mounting standard beam delivery components available from SYNRAD. When considering other components not specifically designed as Series 48 options, please consult the factory for restrictions since excessive weight may cause damage to the laser.

Note: To prevent damage to the laser when mounting optical components, the 8–32 mounting screws must not extend further than 3/16" into the laser faceplate.

operation

Initial start-up

The *Initial start-up* section includes subsections:

- With a UC-2000 Controller
- Without a UC-2000 Controller

Warning

serious
personal
injury

This product emits invisible infrared laser radiation at the 10.6 μm CO_2 wavelength. Since direct or diffuse laser radiation can inflict severe corneal injuries, always wear eye protection when in the same area as an exposed laser beam. Do not allow the laser beam to contact a person. This product emits an invisible laser beam that is capable of seriously burning human tissue.

Always be aware of the beam's path and always use a beam block while testing.

With a UC-2000 Controller

Before your Series 48 laser is put into service for the first time, its functionality should be verified. Follow this procedure to verify the laser system is operating at optimum performance. For this procedure, use the UC-2000 as a stand-alone controller; do not attempt to control the laser or UC-2000 externally.

Note: When performing the initial start-up sequence, check that the factory-installed DB9 jumper plug is installed. If not, you must provide the required Remote Interlock and Remote Key-switch signals to the *DB9 Connector*. See *DB9 connections* in the "Getting Started" section for DB9 pinouts and signal descriptions.

Starting auxiliary equipment

- 1 Ensure that all personnel in the area are wearing protective eyewear.
- 2 Place a beam block 24 inches from the laser aperture to prevent the beam from traveling beyond the work area.
- 3 On water-cooled systems, turn on the chiller (set between 18 °C to 22 °C) and verify that it is delivering 0.5 GPM (48-1), 0.8 GPM (48-2), or 1.5 GPM (48-5) at less than 60 psi of pressure. Examine all cooling connections carefully for leaks.

Caution

possible
equipment
damage

Inlet cooling water temperature must always be maintained above the dew point to prevent condensation and water damage to your laser.

operation

Initial start-up

Note: If you have not yet operated your UC-2000 Universal Laser Controller, refer to the *UC-2000 Laser Controller Operator's Manual* for setup and operation instructions before continuing.

- 4 Set the UC-2000 to *MANUAL* mode, and then set the *PWM Adj Knob* to provide zero percent output (0.0%). The UC-2000's *Lase* indicator should be Off.
- 5 Verify that the laser's *Keyswitch* (if equipped) is in the OFF position.

Starting your Series 48 laser

- 1 If the laser has a Diode Pointer installed, remove its aperture dust cover.
- 2 Move the *Shutter Switch* (if equipped) to the Open position.
- 3 Turn on the DC power supply.
- 4 Rotate the *Keyswitch* (if equipped) to the ON position. Verify that the green *PWR* LED illuminates. If the *Keyswitch* is already ON, turn it OFF, then back ON (or cycle the *Remote Keyswitch* input) to reset the laser.

Note: Each time an OEM laser is powered up or a *Keyswitch* version is cycled OFF/ON, a five-second delay occurs between the time that the *PWR* LED illuminates and the laser is permitted to lase.

- 5 Verify that the red *LASE* LED illuminates dimly after approximately five seconds. This indicates that tickle pulses are being applied to the laser and that it is safe to apply a PWM Command signal.
- 6 Press the UC-2000's *Lase On/Off* button. The *Lase* indicator on the UC-2000 should illuminate.
- 7 Use the *PWM Adj Knob* on the UC-2000 to slowly increase power. The intensity of the laser's *LASE* indicator increases in brightness as the PWM duty cycle increases. The spot where the beam hits the beam block should also increase in brightness to indicate increased power output.

Check your laser's output power

- 1 With the UC-2000 set for maximum power output, measure laser output using a laser power meter (such as SYNRAD's *PW-250 Power Wizard*®) to verify that output power is consistent with the power rating for your particular model. Refer to *General specifications* in the "Technical Reference" section for output power specifications.
- 2 Reduce the PWM duty cycle to 0.0% and press the UC-2000's *Lase On/Off* button to stop lasing. The *Lase* indicator on the UC-2000 turns off and the laser's *LASE* LED turns dim.
- 3 Move the *Shutter Switch* (if equipped) to the Closed position.
- 4 Turn off the DC power supply.

If your Series 48 laser fails to lase, refer to *Troubleshooting* in the "Maintenance/Troubleshooting" section for troubleshooting information.

operation

Initial start-up

Warning

serious
personal
injury

This product emits invisible infrared laser radiation at the 10.6 μm CO_2 wavelength. Since direct or diffuse laser radiation can inflict severe corneal injuries, always wear eye protection when in the same area as an exposed laser beam. Do not allow the laser beam to contact a person. This product emits an invisible laser beam that is capable of seriously burning human tissue.

Always be aware of the beam's path and always use a beam block while testing.

Without a UC-2000 Controller

If you have chosen not to use a UC-2000 to control the laser, follow the procedure below to verify the laser's functionality. You will need to provide a tickle signal and a pulse width modulated (PWM) Command signal to the laser's CTRL input connector. Refer to *Controlling laser power* in the "Technical Reference" section for tickle and PWM Command signal descriptions.

Note: When performing the initial start-up sequence, check that the factory-installed DB9 jumper plug is installed. If not, you must provide the required Remote Interlock and Remote Key-switch signals to the DB9 Connector. See *DB9 connections* in the "Getting Started" section for DB9 pinouts and signal descriptions.

Caution

possible
equipment
damage

Series 48 lasers MUST be provided with a pre-ionizing "tickle" signal during standby or laser "low" periods. This signal is automatically provided by SYNRAD's UC-2000 Universal Laser Controller or FH Series marking head.

A tickle signal keeps the plasma ionized during laser "low" periods and facilitates plasma breakdown and pulse-to-pulse fidelity. Damage to or malfunction of the laser may occur if this, or equivalent drive signals are not provided.

Starting auxiliary equipment

- 1 Ensure that all personnel in the area are wearing protective eyewear.
- 2 Place a beam block 24 inches from the laser aperture to prevent the beam from traveling beyond the work area.
- 3 On water-cooled systems, turn on the chiller (set between 18 °C to 22 °C) and verify it is delivering 0.5 GPM (48-1), 0.8 GPM (48-2), or 1.5 GPM (48-5) at less than 60 psi of pressure. Examine all cooling connections carefully and verify that they do not leak.

operation

Initial start-up

Caution

possible
equipment
damage

Inlet cooling water temperature must always be maintained above the dew point to prevent condensation and water damage to your laser.

- 4 Ensure that your PWM controller is set to zero percent output (0.0%).
- 5 Verify that the laser's *Keyswitch* (if equipped) is in the OFF position.

Starting your Series 48 laser

- 1 If the laser has a Diode Pointer installed, remove its aperture dust cover.
- 2 Move the *Shutter Switch* (if equipped) to the Open position.
- 3 Turn on the DC power supply.
- 4 Rotate the *Keyswitch* (if equipped) to the ON position; the *PWR* LED illuminates. If the *Keyswitch* is ON, turn it OFF, then back ON (or cycle the *Remote Keyswitch* input) to reset the laser.

Note: Each time an OEM laser is powered up or a *Keyswitch* version is cycled OFF/ON, a five-second delay occurs between the time that the *PWR* LED illuminates and the laser is permitted to lase.

- 5 Verify that the red *LASE* LED illuminates dimly after approximately five seconds. This indicates that tickle pulses are being applied to the laser and that it is safe to apply a PWM Command signal.
- 6 Apply a PWM Command signal (a +5 VDC, 5 kHz square wave of 1 μ s to 3 μ s duration) to the laser's *CTRL* connector. If operating a 48-5 laser, apply the signal in parallel to both *CTRL1* and *CTRL2* connectors.
- 7 Slowly increase the duty cycle of the signal. The intensity of the laser's *LASE* indicator increases in brightness as the PWM duty cycle increases. The spot where the beam hits the beam block should also increase in brightness to indicate an increasing power output.

Check your laser's output power

- 1 With your PWM signal source set for maximum power output, measure laser output using a laser power meter (such as SYNRAD's PW-250 Power Wizard®) to verify that output power is consistent with the power rating for your particular model. Refer to *General specifications* in the "Technical Reference" section for output power specifications..
- 2 Reduce the PWM duty cycle to 0.0%. The *LASE* indicator on the laser dims (tickle signal only).
- 3 Move the *Shutter Switch* (if equipped) to the Closed position.
- 4 Turn off the DC power supply.

If your Series 48 laser fails to lase, refer to *Troubleshooting* in the "Maintenance/Troubleshooting" section for troubleshooting information.

operation

This page intentionally left blank.

technical reference

Use information in this section as a technical reference for your Series 48 laser.

This section contains the following information:

- Technical overview – briefly describes Series 48 technology and basic optical setup.
- Controlling laser power – explains various aspects of Series 48 control signals.
- DB9 connections – describes signals and specifications for the side-mounted DB9 connector.
- Integrating Series 48 safety features – describes how to integrate Series 48 safety features into your automated control system.
- Series 48 general specifications – provides specifications for Series 48 lasers.
- Model 48-1 package outline drawing – illustrates laser package and mounting dimensions for Keyswitch and OEM 48-1 10 watt lasers.
- Model 48-2 package outline drawing – illustrates laser package and mounting dimensions for Keyswitch and OEM 48-2 25 watt lasers.
- Model 48-5 package outline drawing – illustrates laser package and mounting dimensions for Keyswitch and OEM 48-5 50 watt lasers.

technical reference

Technical overview

The *Technical overview* section includes subsections:

- Introduction
- Plasma section
- Optical resonator
- Control circuitry
- Optical setup

Introduction

Series 48 lasers incorporate the latest technology in sealed carbon dioxide devices, combining the best features of both waveguide and free space CO₂ laser technology. The all-metal laser tube construction features the ruggedness, stable optical support, and small size of waveguide lasers. Its larger bore (4.8 mm) eliminates the high optical power density of waveguide lasers with their predisposition to optical degradation and incorporates the mode purity and easy optical alignment of free space TEM₀₀ lasers. Low cost is achieved by using simple extruded and welded aluminum structures packaged together with compact, state-of-the-art RF power supplies. The laser is self-contained requiring only the application of power, cooling air or water, and a control signal. It is therefore ideally suited for overhead installation where the laser is gantry-mounted since no RF cable runs are required.

48 Series lasers emit a laser beam with a wavelength of 10.6 microns (μm). The beam shape is square at the laser output aperture, changing to circular at distances of approximately one meter or more from the laser. The laser beam diverges due to diffraction at a full angle of 4 mrad (milliradians), with the beam waist at the output aperture of the laser.

The method of RF excitation on which the Series 48 is based provides excellent discharge stability, easily controlled output power and modulation, and convenient interfacing to automated systems. Coupling between the RF driver and the laser is based on patented switching and transmission line technology. The RF drive operates at around 45 MHz and is matched to the resonant frequency of the plasma tube.

Power control of the laser beam is achieved by pulse width modulation (PWM) of the RF drive circuit. Modulation control can be used to gate the laser on and off at time intervals synchronized with automated processing equipment. It can also be used to control instantaneous power by adjusting the pulse width (PWM duty cycle) at a fixed modulation frequency. Both methods can be used simultaneously.

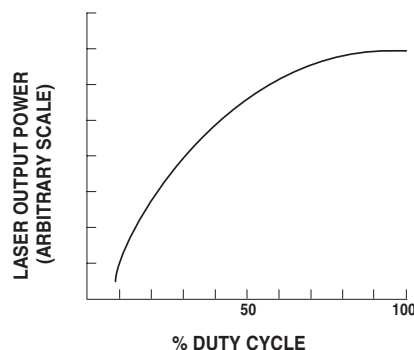

Figure 3-1 Average laser output vs. percent PWM duty cycle

technical reference

Technical overview

As shown in Figure 3-1, the PWM on-time percentage (PWM duty cycle) exerts a non-linear power function as power saturation is approached, flattening out at approximately 95% duty cycle. We recommend using a 95% maximum PWM signal since little or no increase in laser output power occurs between 95% and 100% PWM duty cycle. It is safe to operate at 100% duty cycle by eliminating all PWM control and simply applying on/off gating; however, you can expect a 5% increase in power draw and heat load.

Plasma section

The laser consists of an RF-excited plasma tube with an adjustable mirror on each end, mounted together with the RF drive assembly in a single aluminum chassis. The plasma tube is made of two-inch square cross-section extruded aluminum tubing with pre-machined ends welded on. The mechanical and electrical arrangement of the internal electrode structure is shown schematically in Figure 3-2. The RF drive power is applied between the lower electrode and the plasma tube. The internal resonant circuit induces RF drive on the upper electrode that is 180 degrees out of phase with that of the lower electrode. Thus the voltage between the two RF electrodes is roughly twice that on either electrode, causing the plasma to form only in the 4.8 mm square bore region. The two sidewalls confine the plasma but carry negligible current. The RF electrodes are anodized to assure uniform distribution of RF power throughout the excitation volume. Waste heat is conducted away by all four metal sides of the bore to the outer walls of the plasma tube, where it is transferred to the chassis. In contrast to waveguide lasers that have a closed bore periphery, Series 48 lasers have four slots (small gaps) extending longitudinally along the length of the bore (shown in Figure 3-2). These slots provide electrical insulation between the two pairs of orthogonal electrodes; however, the slots are also effective for diffusion cooling of the laser gas.

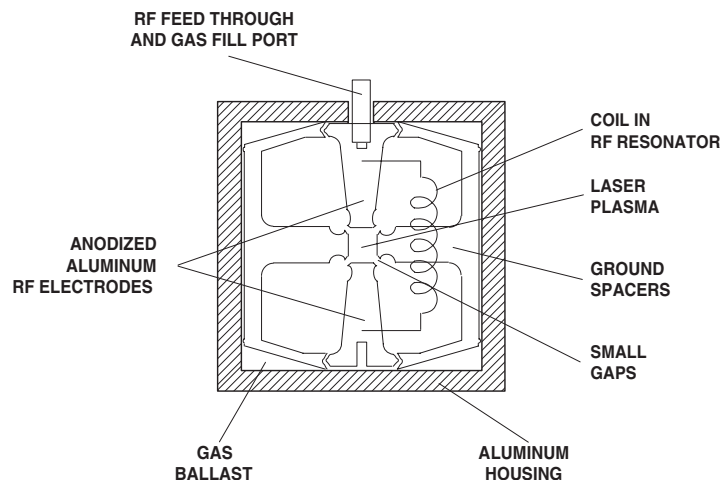

Figure 3-2 Cross section of tube

Optical resonator

The optical resonator consists of a three meter radius of curvature total reflector and a flat Zinc Selenide (ZnSe) output coupler with reflectivities of 95% or 92%. The mirrors are held on with Viton (fluorocarbon) elastomeric o-rings for factory adjustment by means of three Torx head 4–40 screws. No epoxy is used for sealing. The screws are secured by adhesive after alignment.

The 4.8 mm bore, in conjunction with the mirror curvature selected, limits the output beam to TEM₀₀ modes when the mirrors are properly aligned. Small variations in output power (up to 10%) are seen during warm-up as the cavity mirror spacing changes due to thermal expansion of the plasma tube.

technical reference

Technical overview

The output wavelength remains at or near $10.6\ \mu\text{m}$ (typically $10.57\ \mu\text{m}$ to $10.63\ \mu\text{m}$). Beam shape is square at the laser output aperture, changing to circular at distances of approximately one meter or more from the laser with a near gaussian profile in the far field (0.6 m or more). The internal structure and optics of the resonator combine to produce a mode quality of TEM_{00} , 95% purity with an M^2 factor less than 1.2. As shown in Figure 3-3, beam waist diameter is 3.5 mm at the output aperture and full angle divergence due to diffraction is 4 mrad (a 4 mrad full angle divergence means that beam diameter increases 4 mm over every one meter distance traveled).

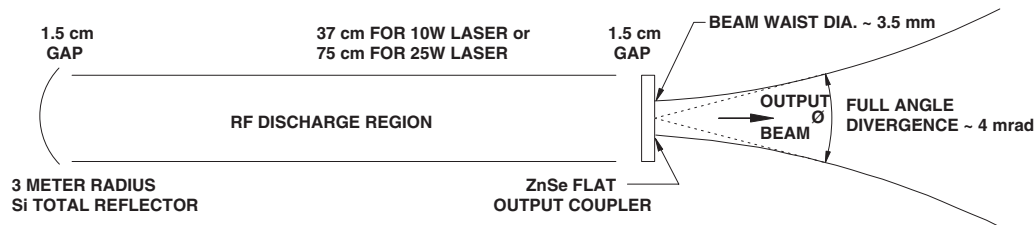

Figure 3-3 Beam characteristics

Control circuitry

Electrical description

Control of laser operation and power output levels is essentially performed using a single PCB. The Control PCB connects the modulated signal to the RF amplifier. It also provides electronics to monitor performance of RF control, output circuitry, input power, temperature, PWM accuracy, provides outputs to an externally accessible connector, and incorporates reverse polarity protection.

Functional differences between model types generally relate to the number of RF channels. Model 48-1 lasers use a single RF electrode requiring a single modulated RF drive input from the Control PCB. The 48-2 uses 2 RF electrodes and requires 2 RF channels, while the 48-5 uses 4 electrodes and 4 RF channels (2 Control PCB's). For the purpose of this description, a single channel will be described. Model specific details relating to differences in electrical characteristics are individually discussed.

The modulated input Command signal is generated externally to the laser and connected to the panel-mounted BNC connector labeled *CTRL*. This signal is connected to an optoisolator, the output of which is applied to the PWM switch control circuit. The PWM switch control circuit gates the PWM switch off and on at the frequency and duty cycle controlled by the modulation source. When the PWM switch closes, a potential of +30 VDC is applied to the RF Driver. The PWM control circuit provides on/off gating of the PWM switch unless disabled by the five-second delay, *Shutter Switch*, or the fault shutdown circuits.

The five-second delay disables PWM output to the RF amplifier for a period of approximately five seconds after the panel-mounted *Keyswitch* and *Remote Keyswitch* link are closed (power ON). On OEM models, the five-second delay period begins on DC power up of the laser.

The *Shutter Switch* allows the operator to temporarily interrupt laser output during active lase modes. A mechanical lever physically blocks the exit aperture and at the same time actuates independent micro-switches that electrically interrupt power to the RF module by disabling the PWM input optoisolator, forcing an "off" state.

technical reference

Technical overview

Fault shutdown conditions

The power input circuit consists of a panel-mounted fuse for overcurrent protection, a dual Schottky shunt rectifier for reverse-voltage protection, a panel-mounted keyswitch, and a normally open MOSFET safety switch. Application of reverse-voltage will normally require fuse replacement.

The output of the *Keyswitch* is connected to the control board through the *DB9 Connector* user port. Note that the supplied DB9 jumper plug can be removed to allow the user to insert a remotely located relay or switch in series with the *Keyswitch*. If the *Keyswitch* is left on or is electrically bypassed, the user can turn the laser on and off, and reset fault shutdowns from a remote location.

The temperature warning message output (pin 5 of the DB9 connector) goes low when the laser tube temperature reaches $54\text{ }^{\circ}\text{C} \pm 2\text{ }^{\circ}\text{C}$ and remains low until tube temperature falls $2\text{ }^{\circ}\text{C}$ below the trigger temperature. The warning message output does not shut down the laser. Over temperature fault shutdown occurs when laser tube temperature reaches $60\text{ }^{\circ}\text{C} \pm 2\text{ }^{\circ}\text{C}$.

Control board operation begins when the supply voltage rises above +18 VDC and remains below +36 VDC. After start-up, the control board will shut the laser down if supply voltage falls below +15 VDC or rises above +36 VDC.

If an electronics failure causes the control board to output PWM power to the RF Drivers in excess of 20% of the commanded PWM input, a fault shutdown will occur.

To reset after any fault shutdown, correct the problem(s) then cycle the *Keyswitch* (or *Remote Keyswitch* if one is present) or remove power to the laser for 30 seconds. During any fault shutdown, the fault shutdown output (pin 1 of the DB9 connector) will latch to low state until a keyswitched reset occurs.

Power-On reset

The Power-On Reset feature will not allow lasing to restart after a power failure or shutdown has occurred until the *Keyswitch* or *Remote Keyswitch* is first cycled off (open circuit condition) and then back on (closed circuit). Power-On Reset is defeated on all OEM versions. OEM customers must provide this required safety feature elsewhere as part of their equipment integration.

RF Driver IV

RF power is provided by a patented single MOSFET transistor power oscillator operating in a tuned feedback circuit. The low-impedance MOSFET output is coupled to the relatively high-impedance laser tube electrode by a ceramic-substrate micro-strip transmission line integral to the RF circuit board.

RF rise time is about $1\text{ }\mu\text{s}$ to deliver a striking voltage of over 500 V peak to the discharge electrodes. A pulse-stretching network on the control board widens the incoming Command input so that the tickle pulses delivered from the RF Driver are sufficient to provide a plasma ready state without emission.

The RF drive is not centered on a frequency authorized for significant incidental radiation (ISM bands around 27 and 40 MHz). The power module must therefore be shielded effectively which is accomplished by integrating the plasma tube and drive into a single assembly. Refer to Figure 3-4 for the RF Driver IV circuit schematic.

technical reference

Technical overview

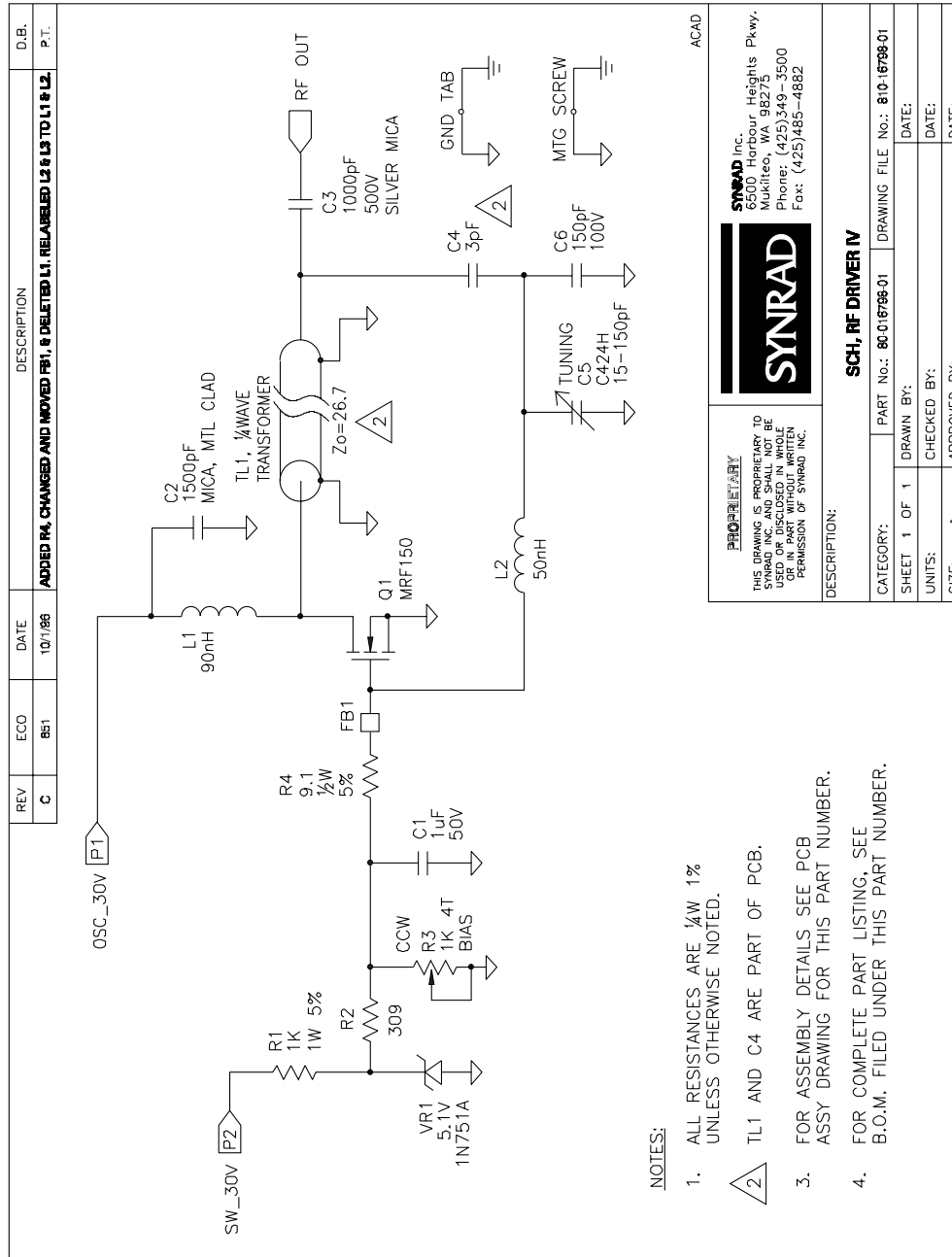

Figure 3-4 RF Driver IV

Cooling requirements

Series 48 electronics are mounted opposite the laser tube in the smaller section of the “H” bay and share the same cooling removal as the plasma tube. Typical efficiency of CO₂ laser plasma tubes operating in a TEM₀₀ mode is 10% to 12% (radiation out to RF power in). Factor in the conversion efficiency of AC input to RF output and the overall “wall plug” efficiency of these lasers drops to about 6% to 8%, resulting in a considerable amount of heat removal, even at 10 W and 25 W output power levels; therefore, external cooling in the form of forced air- or water-cooling is required.

technical reference

Technical overview

Duo-Lase[®] operation (48-5)

The 48-5 laser combines two laser tubes for twice the output of a standard laser. The outputs from two 25 W sealed CO₂ tubes are combined optically to provide a single diffraction-limited beam at 50 W. This optical combining technique is based on the fact that each laser is linearly polarized, allowing the use of a polarization sensitive beam combiner to achieve 98% efficiency in combining the two beams. The two components of the resulting beam are spatially parallel and collinear, reducing the normal temporal and spatial variations of a single laser. Output polarization is random and therefore superior for many cutting applications.

The 48-5 laser uses two control boards and four RF drivers. The control boards are tied together electronically so that if a failure mode shuts down either board, both laser tubes are turned off. The control boards are equipped with individual fuses for each RF driver PWM output. In the event of an RF driver failure, only that fuse will open, allowing other RF drivers in the system to continue operating. Unless both fuses are open on a given control board, no shutdown will occur, nor is there a fault output signal.

In general, the two Command inputs (*CTRL1* and *CTRL2*) should always be driven identically with a “Y” or “T” connector. For special applications in redundant or ultra-wide dynamic range systems, it is permissible to drive only one Command input; however, the beam’s random polarization is compromised.

Optical setup

After selecting a CO₂ laser for your processing system, the two most important elements to consider are: (1) delivery optics to transmit the beam to the work area; and (2) focusing optics to focus the beam onto the part or material to be processed. Each element is crucial in the development of a reliable laser-based material processing system and each element should be approached with same careful attention to detail.

Delivery optics

Divergence, or expansion, of the laser beam is important for materials processing since a larger beam entering the focusing optic produces a smaller focused spot. Because the laser beam diverges slowly, increasing 4 mm in diameter over every meter, Series 48 lasers should be mounted a distance of 1.0 m to 1.5 m (40" to 60") away from the work area. Right angle turning mirrors are often used in conjunction with the laser mounting position to obtain this distance. Figure 3-5 shows how right angle turning mirrors in a “flying optics” setup create this longer beam path.

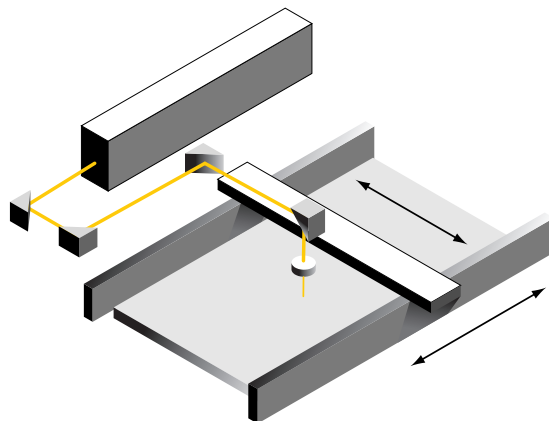

Figure 3-5 “Flying optics” beam path

technical reference

Technical overview

Expander/collimators are optical devices that reduce beam divergence while at the same time increasing beam diameter by a selectable magnification factor. Adding an expander/collimator to the “flying optics” setup shown above would substantially reduce beam divergence and any variance in beam diameter caused by the changing optical path length. In fixed-length delivery systems where the laser is positioned only one meter away from the focusing optic and a small spot size is required, an expander/collimator is again the best solution to provide the required beam expansion before reaching the focusing optic.

Focusing optics

When selecting a focusing optic, the primary consideration should be material thickness and any vertical tolerances that occur during final part positioning rather than making a selection based only on minimum spot size. The chosen focal length should create the smallest possible focused spot while providing the depth of field required for the material to be processed.

Caution

possible
equipment
damage

Small amounts of contaminants on the laser’s output window (or on any optic in the beam path) can absorb enough energy to damage the optic. Inspect all beam delivery optics periodically for signs of contaminants and carefully clean as required. In dirty environments, purge laser optics using filtered air or nitrogen to prevent vapor and debris from accumulating on optical surfaces.

Optics are fragile and must be handled carefully, preferably by the mounting ring only. Cleanliness is another important issue affecting performance; a dirty or scratched lens will underperform and exhibit a vastly shortened lifetime. When the application requires air (instead of nitrogen) as a purge gas, use only breathing quality air available in cylinders from a welding supply company. Compressed shop air contains minute particles of oil and other contaminants that will damage optical surfaces. If compressed shop air is the only choice available, it must be filtered and dried to the specifications shown in Table 3-1.

Table 3-1 Gas purity specifications

Purge Gas	Specification
Nitrogen	High Purity Grade 99.9500% purity or better
Air	Breathing Grade 99.9996% purity or better
Air	Compressed 99.9950% purity or better, water-free; oil filtered to 5 mg/m ³ or better; particulate filtered to < 1.0 micron; dried to lower dew point below coolant temperature setpoint

technical reference

Controlling laser power

The *Controlling laser power* section includes subsections:

- Control signals
- Operating modes

Control signals

Much of the information provided in this section describes the use of a SYNRAD UC-2000 Universal Laser Controller to provide PWM Command signals to the Series 48 laser. If using an alternate method of laser control, thoroughly review this section, *Controlling laser power* for an understanding of the signal requirements necessary to control SYNRAD Series 48 lasers. For more information about UC-2000 operation, please consult the *UC-2000 Laser Controller Operator's Manual*.

Tickle pulse

All Series 48 lasers require a 1 μs 'tickle' pulse delivered at a 5 kHz clock frequency from the Controller. Tickle pulses pre-ionize the laser gas to just below the lasing threshold so that a further increase in pulse width adds enough energy to the plasma to cause laser emission. This tickle signal causes the laser to respond predictably and almost instantaneously to PWM Command signals, even when there is considerable delay (laser off time) between applied Command signals. Series 48 lasers contain a precision pulse stretching circuit that is preset to accept a 1 μs $\pm 20\%$ no-lase, tickle pulse. Lase threshold is factory-preset for 3 μs ± 0.5 μs based on a PWM and tickle frequency Command input of 5 kHz.

Caution

possible
equipment
damage

Applying PWM Command pulses directly to the laser without first sending tickle pulses, will cause unpredictable laser emission, degrade optical rise time, and may lead to RF Driver failure.

The UC-2000 (or FH Series marking head) does not produce tickle pulses continuously, but generates them only when the PWM Command signal is low. Tickle pulses are sent one tickle period, 200 μs , after the falling edge of a PWM Command signal pulse. Figure 3-6 illustrates tickle pulse parameters.

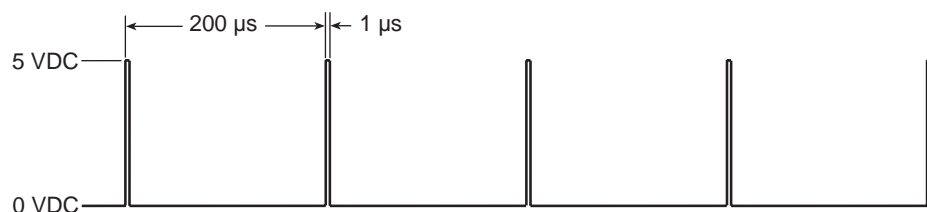

Figure 3-6 Tickle pulse waveform

A 1 μs tickle pulse at frequencies greater than 5 kHz may cause unintended lasing. Special care must be taken to maintain plasma ionization without lasing at tickle frequencies greater than 5 kHz. If sending 1 μs tickle pulses at 5 kHz, PWM signals can be sent at an independent, higher frequency but must go to near zero (< 1%) duty cycle to ensure laser turn-off.

technical reference

Controlling laser power

Pulse width modulation (PWM)

Pulse Width Modulation, or PWM, controls laser power by varying the duty cycle of the laser's RF amplifiers, which in turn control the time-averaged RF power applied to the laser. Because laser output follows PWM input with a rise and fall time constant of $\sim 100 \mu\text{s}$, the laser cannot precisely follow Command signal frequencies over 5 kHz with duty cycles greater than 50%. Typically, the depth of modulation for a 50% duty cycle is 90 to 100% at 2 kHz and 60 to 80% at 5 kHz. Figure 3-7 shows Series 48 optical waveforms at two different modulation frequencies.

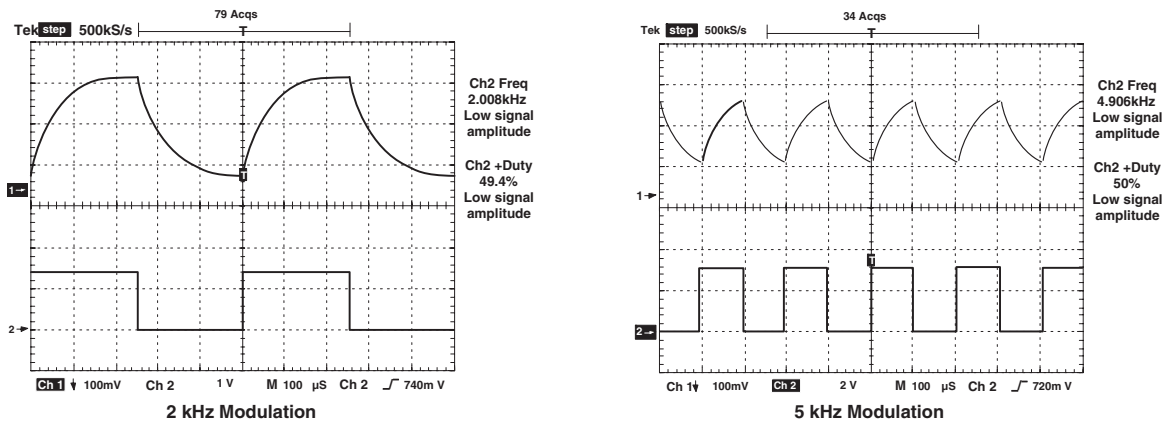

Figure 3-7 Series 48 waveforms

Series 48 lasers are designed to operate at Command signal base frequencies up to 20 kHz; however, the choice of PWM frequency depends on the user's specific application. In the majority of laser applications, the UC-2000's default Command signal frequency of 5 kHz has proven to work well. When considering Command frequencies at 5 kHz or below, please review *Marking/engraving operation* later in this section. For high-speed motion applications that cannot tolerate any ripple in the optical beam response but still need adjustable power levels, we recommend the use of higher PWM frequencies, up to 20 kHz maximum. At 20 kHz, the laser's optical beam response no longer follows the Command input and is very nearly a DC value with just a small amount of ripple present.

Command signal

Warning

serious
personal
injury

Always use shielded cable when connecting your PWM Command signal source to the laser's CTRL connections. In electrically-noisy environments, long lengths of unshielded wire act like an antenna and may generate enough voltage to trigger uncommanded lasing.

The modulated Command signal applied to Series 48 lasers has three parameters: signal amplitude, base frequency, and PWM duty cycle. By changing these parameters, you can command the beam to perform a variety of marking, cutting, welding, or drilling operations.

technical reference

Controlling laser power

Signal amplitude is either logic low, corresponding to laser beam off, or logic high, corresponding to beam on, using TTL- or CMOS-compatible voltage levels. The logic low (laser off) voltage, typically 0 V can range from 0.0 V to +0.5 VDC while the logic high (laser on) voltage, typically 5 V, can range from +3.5 V to +10 VDC. As a reference, the signal output for a UC-2000 Controller ranges from 0.0 V to +0.5 VDC (laser off) and from +3.5 V to +5.0 VDC (laser on).

Base frequency is the rate at which the amplitude is switched between its low and high logic states. The standard base frequency is 5 kHz, which has a period of 200 μ s. Maximum PWM frequency is 20 kHz.

The third parameter, PWM duty cycle, is the percentage of the period that the Command signal is high. If the Command signal's amplitude (at 5 kHz) is high for 100 μ s and low for 100 μ s, it has a 50% duty cycle; if the amplitude is high for 190 μ s and low for 10 μ s, it has a 95% duty cycle. Figure 3-8 illustrates Command signal parameters.

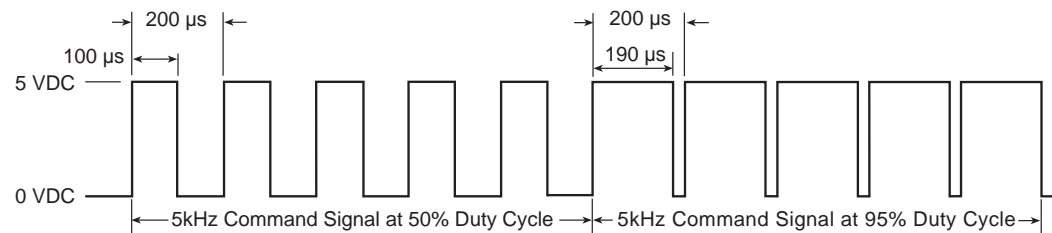

Figure 3-8 PWM Command signal waveform

Operating modes

Caution

possible
equipment
damage

Applying PWM Command pulses directly to the laser without first sending tickle pulses, will cause unpredictable laser emission, degrade optical rise time, and may lead to RF Driver failure.

External control

In addition to controlling your Series 48 laser using a UC-2000 Controller, controlling the laser externally, without a UC-2000, is also possible. The two primary elements of laser control are gating, the ability to turn the laser on and off at the appropriate times, and power, the ability to control the laser's output energy. Both gating and power can be handled by a device such as a personal computer, Programmable Logic Controller (PLC), or a function generator capable of sending PWM pulses at the proper time (gating) and with the proper duty cycle (power) using TTL- or CMOS-compatible voltage levels.

The PWM input on Series 48 lasers consists of an optoisolated input LED. The PWM input frequency can range from DC (0 Hz) to 20 kHz. Maximum current load for 48-1/48-2 lasers is 6 mA @ 5 VDC; for 48-5 dual-tube lasers, maximum current load is 12 mA @ 5 VDC. Table 3-2 shows minimum, maximum, and nominal voltage levels for On and Off logic states.

technical reference

Controlling laser power

Table 3-2 PWM Command signal levels

Laser State	Vmin	Nominal	Vmax
Beam Off (Logic low)	0.0 VDC	0.0 VDC	+0.5 VDC
Beam On (Logic high)	+3.5 VDC	+5.0 VDC	+10 VDC

Analog voltage or analog current control

Although Series 48 lasers cannot be controlled directly by analog voltage or current signals, this type of control is possible when using the UC-2000 Controller. The Controller is connected normally to the laser and analog voltage or current signals sent to the UC-2000's ANV/C connector then control both gating and power.

To generate the correct analog voltage from a computer or PLC, a Digital-to-Analog (D/A or DAC) card capable of generating 0 V (laser off) to 10 V (maximum laser power) must be installed. To generate the proper analog current, install a D/A card that can generate 4 mA (laser off) to 20 mA (maximum power). Software able to control your analog output card is required for both configurations.

The UC-2000 Controller can also be commanded remotely through the UC-2000's RS-232 serial port. User-developed software can send operating mode, lase, setup, and PWM percentage commands as well as poll the Controller for its current operating status. Refer to the *UC-2000 Laser Controller Operator's Manual* for further information about REMOTE operation.

Continuous wave (CW) operation

In some applications, such as high speed marking or cutting, the time constant of the laser and the PWM modulation causes a series of dots that may be visible on the marking surface instead of a "clean" line. Operating the laser in CW mode will prevent this behavior from occurring.

To operate the laser in CW mode, a constant +5 VDC signal is applied to the CTRL input(s) of the laser. This constant voltage source forces the internal switching electronics to remain on, providing continuous and uninterrupted laser output power.

Note: When operating in CW mode, laser power output cannot be adjusted. If you require an adjustable output power level, refer to the *Pulse width modulation (PWM)* section for information regarding high frequency operation.

Gated operation

In many marking and cutting applications, the laser is required to pulse, or gate, on and off in synchronization with an external control signal (typically from a computer or function generator operating in the range from DC to 1 kHz). To pulse or gate the laser, connect a signal providing TTL-level pulses to the Gate connector on the rear panel of the UC-2000.

technical reference

Controlling laser power

Users who intend to use a gating signal should set the UC-2000's gate input logic to internal pull-down (normally off) mode. This prevents the beam from being enabled unless a TTL logic high (+3.5 V to 5.0 VDC) signal is applied to the *Gate* input connector. In the pull-down (normally off) mode an asserted logic low state, short circuit to ground, or an open or disconnected *Gate* input locks the beam off.

Warning

serious
personal
injury

The UC-2000's default factory gate logic is set to internal Pull-Up (normally on) mode. A TTL high input signal OR an open (disconnected) gate connector will cause the beam to turn on. To gate the beam off, apply a logic low input, short circuit the *Gate* input connector, or reconfigure the Controller to Gate Pull-Down (normally off) operation.

See the *UC-2000 Laser Controller Operator's Manual* for further information on setting up the UC-2000 Controller to gate the laser.

Many CO₂ lasers operating in applications requiring short gating pulses at repetition rates below 500 Hz will exhibit some leading edge overshoot regardless of the PWM frequency. This occurs because a cooler lasing medium (the CO₂ gas) is more efficient than a hotter one. This overshoot is more pronounced at lower gating frequencies since the gas has a longer time to cool down between Command signal pulses.

Marking/engraving operation

When the delay between the end of one PWM Command signal pulse and the beginning of the next PWM pulse exceeds 200 μ s (less than or equal to 5 kHz), the UC-2000 Controller or FH Series marking head sends a tickle pulse to maintain plasma ionization in the tube. Because the Controller can not anticipate when the next PWM Command pulse will arrive, the tickle pulse can effectively merge with a PWM signal that follows closely afterwards. When the PWM pulse that follows is short, causing the tickle pulse to become a significant fraction of the PWM pulse duration, then the tickle pulse effectively substantially increases the length of the PWM pulse it has merged with. For subtle marking applications on sensitive, low threshold materials this lengthened PWM pulse may affect mark quality.

While this situation can occur when using PWM Command signal frequencies of 5 kHz and less, it is important to note that it isn't the Command signal frequency itself that is the determining factor but rather this behavior happens only when the off time between PWM pulses exceeds 200 μ s.

technical reference

DB9 connections

Series 48 lasers are equipped with a female DB9 connector mounted to the sidewall of the laser. This connector provides the user with a convenient method for monitoring fault conditions (over temperature, control/RF circuitry failure) and adds remote interlock, remote keyswitch (relay or switch), message output, and remote LED indicator capability. DB9 pin assignments and functions are fully described in Table 3-4 on the following page.

A factory-installed jumper plug is attached to the DB9 Connector on each laser to enable normal operation. Two jumpers (see Figure 3-9) are wired to the plug. One jumper between pins 6 and 7 closes the *Remote Keyswitch* function, and the other jumper between pins 3 and 4 closes the *Remote Interlock*. If this jumper plug is removed, it is essential that pin 3 be jumpered to pin 4 (or pin 2) or be connected to external “remote interlock” circuitry in order to enable lasing. To take advantage of the DB9 functions described in Table 3-4, you must manufacture a connecting cable and configure DB9 connections for proper operation in your integrated system. A spare DB9 male connector and cover is included with each laser to facilitate easy cable manufacture.

Note: On lasers manufactured as OEM (-S) version lasers, i.e. without a *Keyswitch*, the *Remote Interlock* function is bypassed internally. For OEM customers wishing to access the *Remote Interlock* feature via the DB9 connector, please consult the factory for details.

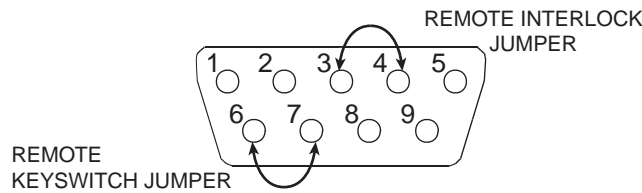

Figure 3-9 Factory-installed DB9 jumper plug wiring

Table 3-3 provides “dry circuit” (zero voltage) specifications for the Remote Keyswitch signal, pin 6 and pin 7 and the Remote Interlock signal on pin 3.

Table 3-3 Remote Keyswitch and Remote Interlock signal specifications

Signal State	Specification
ON (Contact Closed)	≤ 10 Ohms
OFF (Open Circuit)	≥ 100 kOhms
	Contact rating = 50 VDC, < 2 mA minimum (dry circuit)

technical reference

DB9 connections

Table 3-4 DB9 pin assignments

Pin #	Signal Name	Description / Purpose
1	Fault Shutdown Output	Indicates failure of internal control/RF circuitry or existence of overtemperature ($> 60\text{ }^{\circ}\text{C} \pm 2\text{ }^{\circ}\text{C}$), overvoltage, or undervoltage fault. This active low signal (in reference to pin 2 or pin 4) transitions from +15 V to 0 VDC when a fault occurs. Provides user with control signal to disable external systems in the event of a fault. See Note 1.
2	Signal Ground	Signal/chassis ground for pins 1, 3, 5, 8, and 9.
3	Remote Interlock Connection	Disables laser when opened by a remote door or housing safety interlock. As shipped, pins 3 and 4 are jumpered to disable the <i>Remote Interlock</i> function. Allows an open external interlock switch to shut down the laser. Ground pin 3 only; do not apply voltage to this pin. See Note 2. This feature is internally bypassed on OEM models.
4	Signal Ground	Signal/chassis ground for pins 1, 3, 5, 8, and 9.
5	Message Output	Message Output goes low (in reference to pin 2 or pin 4) when laser tube temperature reaches $54\text{ }^{\circ}\text{C} \pm 2\text{ }^{\circ}\text{C}$ and remains low until temperature falls $2\text{ }^{\circ}\text{C}$. Provides user with a pre-shutdown temperature warning. Does not shut down the laser. See Note 1.
6	Remote Keyswitch Input	For connecting a remote relay or switch in series with the laser <i>Keyswitch</i> . Allows user to control laser on/off /reset from a remote location. Connect pin 6 to pin 7 to run; open this circuit to stop or reset faults. As shipped, pins 6 and 7 are jumpered to disable the <i>Remote Keyswitch</i> function. See Note 2 and Note 3.
7	Remote Keyswitch Output	See pin 6 description above. Pin 7 is at DC line potential (+30 VDC) when the <i>Keyswitch</i> is on or bypassed. Allows user to control laser on/off /reset functions from a remote location. See Note 3 and Note 4.
8	Remote Lase LED Output	Current and voltage limited output for direct connection to LED or LED-input optoisolator. Allows user to connect a remote <i>LASE</i> LED indicator. See Note 5.
9	Remote Ready LED Output	Current and voltage limited output for direct connection to LED or LED-input optoisolator. Allows user to connect a remote Ready (<i>PWR</i>) LED indicator. See Note 5.

- 1 Allen-Bradley (A-B) compatible outputs (pins 1 and 5) are Active Low. Specifications: OFF: +15 VDC, 5 mA into 3 kOhm. ON: < 1 VDC, sinking 100 mA.
- 2 “Dry-circuit” (zero voltage) external switches are required since current into remote interlock and debounced remote keyswitch pins is negligible.
- 3 Connecting an LED to pins 6 or 7 to indicate keyswitch status requires an external current-limiting resistor.
- 4 The remote keyswitch output pin is not current-limited or fused.
- 5 Pins 8 and 9 can be directly connected to the anodes of LEDs or LED-input optoisolators without external current limiting devices. Connect LED cathodes to pin 2 or 4. Current is limited internally to 20 mA at 3.3 V maximum.

technical reference

Integrating Series 48 safety features

The *Integrating Series 48 safety features* section includes subsections:

- Keyswitch functions
- Remote Interlock functions

The Series 48 *DB9 Connector* allows system integrators or end-users to integrate Series 48 laser safety features into their control system. In particular, the Series 48 *Remote Keyswitch* and *Remote Interlock* functions serve to disable DC power to the laser's RF driver. Without power, the RF driver cannot supply PWM Command or tickle signals to the resonator, causing the CO₂ gas to remain in a zero-energy state.

Keyswitch functions

Keyswitch lasers

After DC power-up, or after a fault or open interlock condition, the *Keyswitch* must be toggled to reset the laser, which enables the *PWR LED* and signals that DC power is applied to the RF driver. For *Keyswitch* lasers used in automated control systems, this reset function is provided by the Remote Keyswitch signal via pins 6 and 7 on the *DB9 Connector*. To use this “remote keyswitch” functionality, first place the *Keyswitch* in the ON position. To reset a fault condition, open and then close a “dry-circuit” (zero voltage) switch or relay contact between pin 6, Remote Keyswitch Input, and pin 7, Remote Keyswitch Output. Reconnecting pin 6 to pin 7 applies power to the RF driver and begins a five-second delay after which lasing is enabled. The RF driver is disabled as long as the remote keyswitch connection is open.

Your control system can monitor the laser's power-on status through the *DB9 Connector* by connecting your system's input between pin 9, Remote Ready LED Output, and pin 2 or pin 4, Signal Ground. The Remote Ready LED Output goes active when the laser is enabled (*PWR LED* turns On), indicating that lasing is possible after the five-second delay. The output is inactive (*PWR LED* off) when lasing is disabled. Refer back to Table 3-4, *DB9 pin assignments* for specific details.

Important Note: Pin 9, the Remote Ready LED Output, is a current- and voltage-limited output meant only for direct connection to an LED or LED-input optoisolator.

OEM lasers

On OEM lasers, the *PWR LED* illuminates on DC power-up and five seconds later DC power is applied to the RF driver. To reset an OEM fault condition, remove DC power for 30 seconds and then reapply power to the laser or toggle (open, then close) the Remote Keyswitch signal via pins 6 and 7 on the *DB9 Connector*. To use this OEM remote reset functionality, open and then close a “dry-circuit” (zero voltage) switch or relay contact between pin 6, Remote Keyswitch Input, and pin 7, Remote Keyswitch Output. Reconnecting pin 6 to pin 7 applies power to the RF driver and begins a five-second delay after which lasing is enabled.

Your control system can monitor the laser's power-on status through the *DB9 Connector* by connecting your system's input between pin 9, Remote Ready LED Output, and pin 2 or pin 4, Signal Ground. The Remote Ready LED Output goes active when the laser is enabled (*PWR LED* turns On), indicating that lasing is possible after the five-second delay. The output is inactive (*PWR LED* off) when lasing is disabled. Refer back to Table 3-4, *DB9 pin assignments* for specific details.

Important Note: Pin 9, the Remote Ready LED Output, is a current- and voltage-limited output meant only for direct connection to an LED or LED-input optoisolator.

technical reference

Integrating Series 48 safety features

Remote interlock functions

Keyswitch lasers

Interlock circuits are often used to disable machinery when a shield, panel, or door is opened. The Series 48 remote interlock wires directly into an external, zero-voltage remote interlock circuit to prevent lasing by removing DC power from the laser's RF driver boards when the circuit is electrically "open".

Remote interlock functionality is provided by the Remote Interlock Connection via pin 3 on the *DB9 Connector*. Lasing is enabled when the Remote Interlock Connection signal is closed and disabled when the Remote Interlock Connection signal is electrically "open". DC power is applied to the RF driver only when the Remote Interlock Connection signal is closed (*PWR LED* is illuminated). When the Remote Interlock Connection is opened and then closed, you must toggle the *Keyswitch* or Remote Keyswitch Input to reset the laser.

To use the Series 48 remote interlock feature, connect pin 3, Remote Interlock Connection, through your "dry-circuit" (zero-voltage) interlock circuit and then ground the circuit to pin 2 or pin 4, Signal Ground.

Caution

possible
equipment
damage

Do not apply a voltage to pin 3, Remote Interlock Connection on the *DB9 Connector*, the laser will be damaged. This input is a "dry-circuit" (zero voltage) input and must be grounded to either pin 2 or pin 4 to complete the interlock circuit.

Lasing is enabled when pin 3 is grounded (when the external interlock circuit is closed). If the external interlock circuit opens, then pin 3 opens and lasing is disabled. To enable lasing again, you must close the interlock circuit and toggle the *Keyswitch* or Remote Keyswitch Input. This resets the laser and begins a five-second delay after which lasing is enabled.

Your control system can monitor the laser's power-on status through the *DB9 Connector* by connecting your system's input between pin 9, Remote Ready LED Output, and pin 2 or pin 4, Signal Ground. The Remote Ready LED Output goes active when the laser is enabled (*PWR LED* turns On), indicating that lasing is possible after the five-second delay. The output is inactive (*PWR LED* off) when lasing is disabled. Refer back to Table 3-4, *DB9 pin assignments* for specific details.

Important Note: Pin 9, the Remote Ready LED Output, is a current- and voltage-limited output meant only for direct connection to an LED or LED-input optoisolator.

OEM lasers

The remote interlock function is internally bypassed on OEM lasers; to enable this feature, please consult the factory for details.

technical reference

Series 48 general specifications

Table 3-5 Series 48 general specifications

Parameter	Model 48-1	Model 48-2	Model 48-5
Output Specifications			
Wavelength (microns)	10.57–10.63	10.57–10.63	10.57–10.63
Power Output ^{1,2}	10 W	25 W	50 W
Power Stability ³	±10%	±5%	±5%
Mode Quality (at 1/e ²)	TEM ₀₀ , 95% purity M ² < 1.2	TEM ₀₀ , 95% purity M ² < 1.2	TEM ₀₀ , 95% purity M ² < 1.2
Beam Waist Size	3.5 mm	3.5 mm	3.5 mm
Beam Divergence	4 mrad	4 mrad	4 mrad
Ellipticity	< 1.2	< 1.2	< 1.2
Polarization	Linear, vertical	Linear, vertical	Random
Extinction ratio	50:1 minimum	50:1 minimum	N/A
Rise Time	< 150 µs	< 150 µs	< 150 µs
Modulation (Optical response)	up to 20 kHz	up to 20 kHz	up to 20 kHz
Input Specifications			
Power Supply			
Voltage	30 VDC	30 VDC	30 VDC
Maximum Current	7 A	14 A	28 A
Command Input Signal			
Voltage	+3.5 V to +10.0 VDC		
Current	6 mA @ +5.0 VDC		
Frequency ⁴	DC–20 kHz		
Duty Cycle	0%–100%		
Logic Low State (Vmin–Vmax)	0.0 V to +0.5 VDC		
Logic High State (Vmin–Vmax) ...	+3.5 V to +10.0 VDC		
Cooling Specifications^{5,6}			
Model 48-1	(Air-cooled)	(Water-cooled)	
Maximum Heat Load, laser	300 W	300 W	
Minimum Flow Rate	250 CFM × 2 fans	0.5 GPM, < 60 PSI	
Coolant Temperature	≤ 40 °C, ambient	18 °C to 22 °C	
Model 48-2	(Air-cooled)	(Water-cooled)	
Maximum Heat Load, laser	500 W	500 W	
Minimum Flow Rate	250 CFM × 4 fans	0.8 GPM, < 60 PSI	
Coolant Temperature	≤ 40 °C, ambient	18 °C to 22 °C	

technical reference

Series 48 general specifications

Parameter

Cooling Specifications (cont.)^{5,6}

Model 48-5	(Water-cooled)
Maximum Heat Load, laser	800 W
Minimum Flow Rate	1.5 GPM, < 60 PSI
Coolant Temperature	18 °C to 22 °C

Physical Specifications

48-1

Length	16.9 in (42.9 cm)
(incl. cooling tubes)	18.1 in (46.0 cm)
Width	2.8 in (7.1 cm)
Height	4.2 in (10.7 cm)
Weight	9.0 lbs (4.1 kg)

48-2

Length	31.9 in (81.0 cm)
(incl. cooling tubes)	33.1 in (84.1 cm)
Width	2.8 in (7.1 cm)
Height	4.2 in (10.7 cm)
Weight	18.0 lbs (8.2 kg)

48-5

Length	34.9 in (88.6 cm)
(incl. cooling tubes)	36.4 in (92.5 cm)
Width	5.3 in (13.5 cm)
Height	4.5 in (11.4 cm)
Weight	44.0 lbs (20.0 kg)

* Specifications subject to change without notice.

- 1 This power level is guaranteed for 12 months regardless of operating hours.
- 2 Minimum 30 VDC input voltage to obtain guaranteed output power.
- 3 From cold start (guaranteed).
- 4 FCC and CE tested at 5 kHz.
- 5 Lasers with output power ≥ 50 W must be water-cooled. Lasers with output < 50 W can be either water- or air-cooled depending on their duty cycle. For duty cycles $> 50\%$, water-cooling is strongly recommended. Note that water-cooling improves power stability at any duty cycle.
- 6 Inlet cooling water temperature should always be maintained above the dew point to avoid condensation and water damage to the laser.

technical reference

Model 48-1 package outline drawing

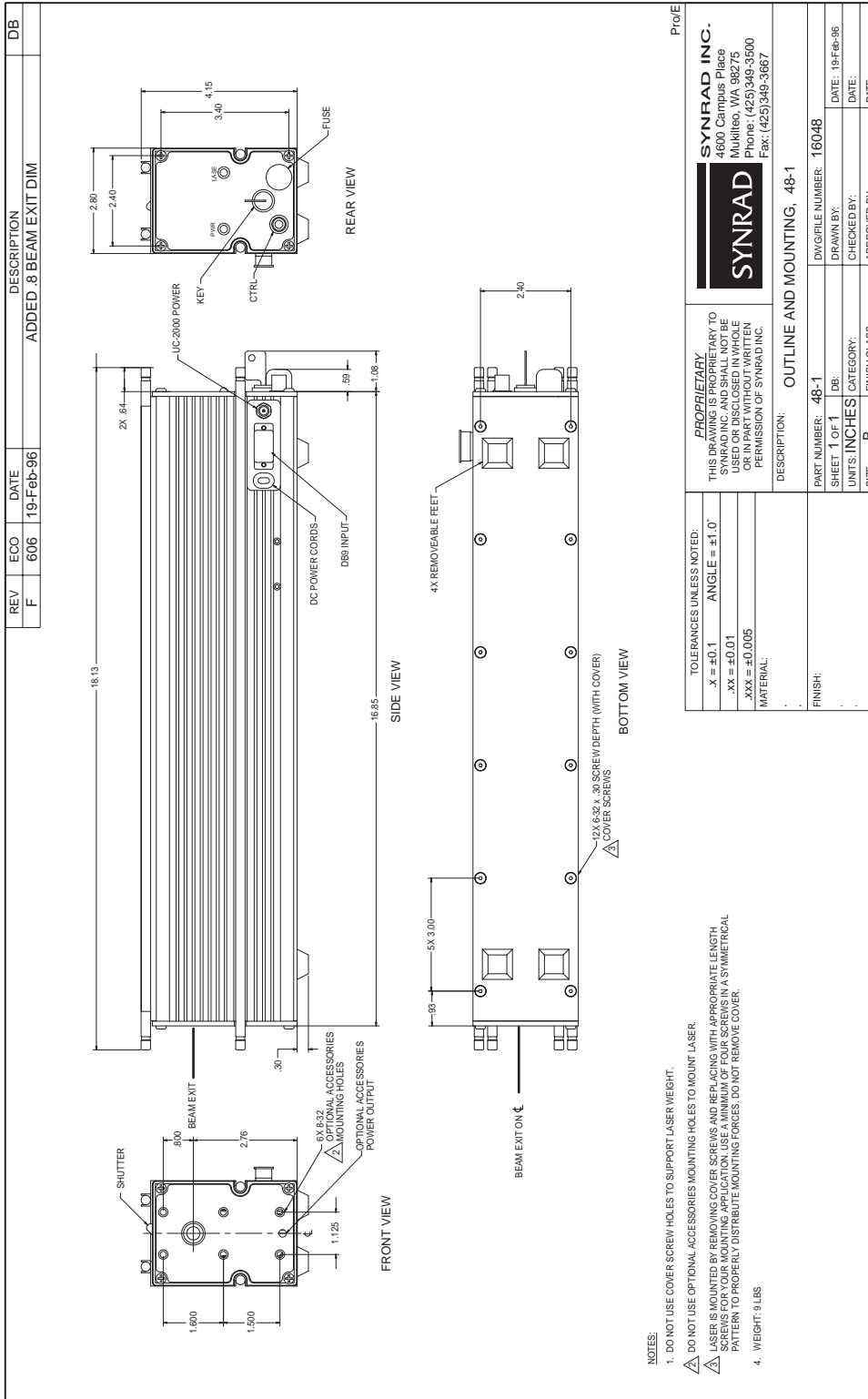

Figure 3-10 Model 48-1 package outline and mounting dimensions

technical reference

Model 48-2 package outline drawing

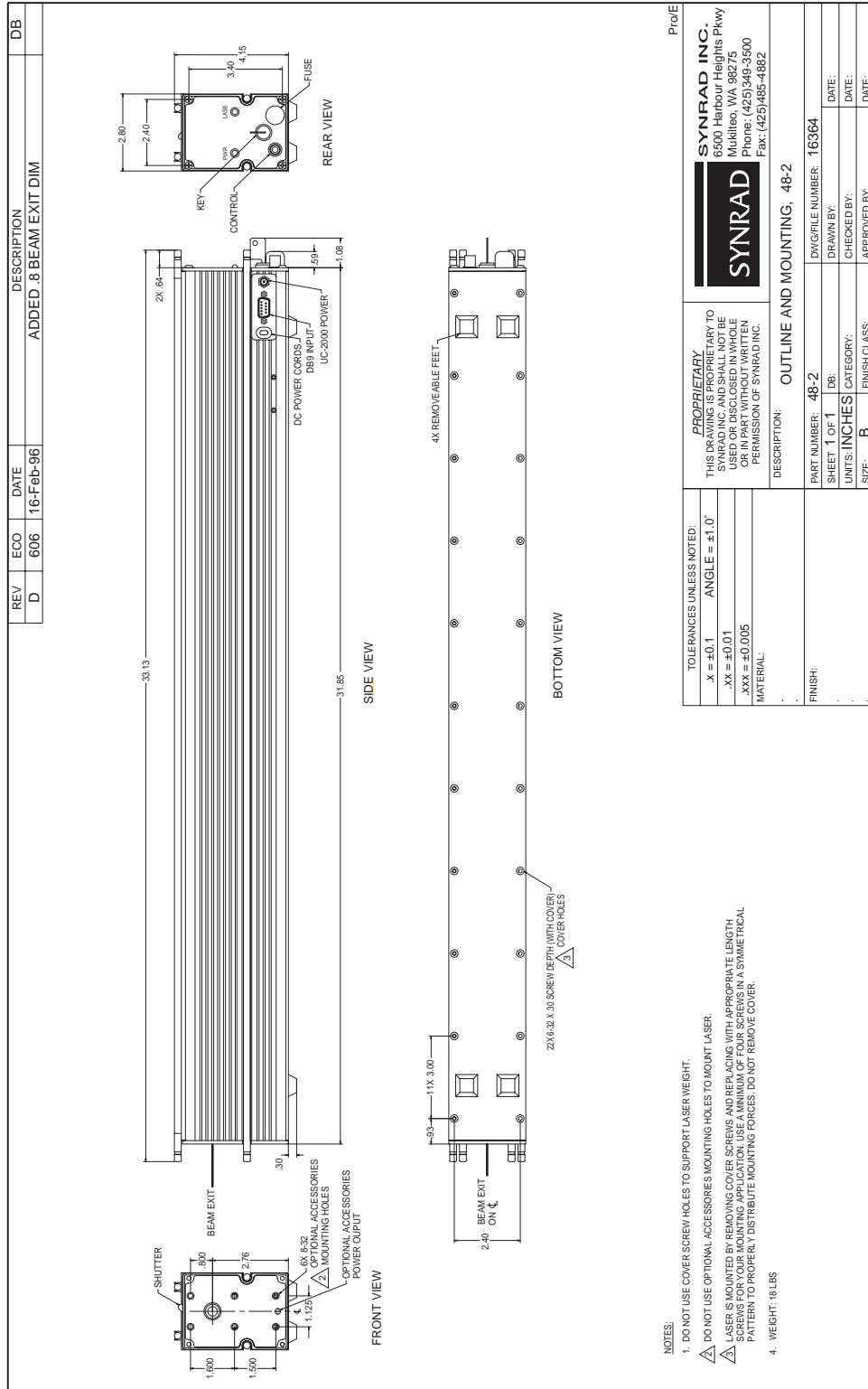

Figure 3-11 Model 48-2 package outline and mounting dimensions

technical reference

Model 48-5 package outline drawing

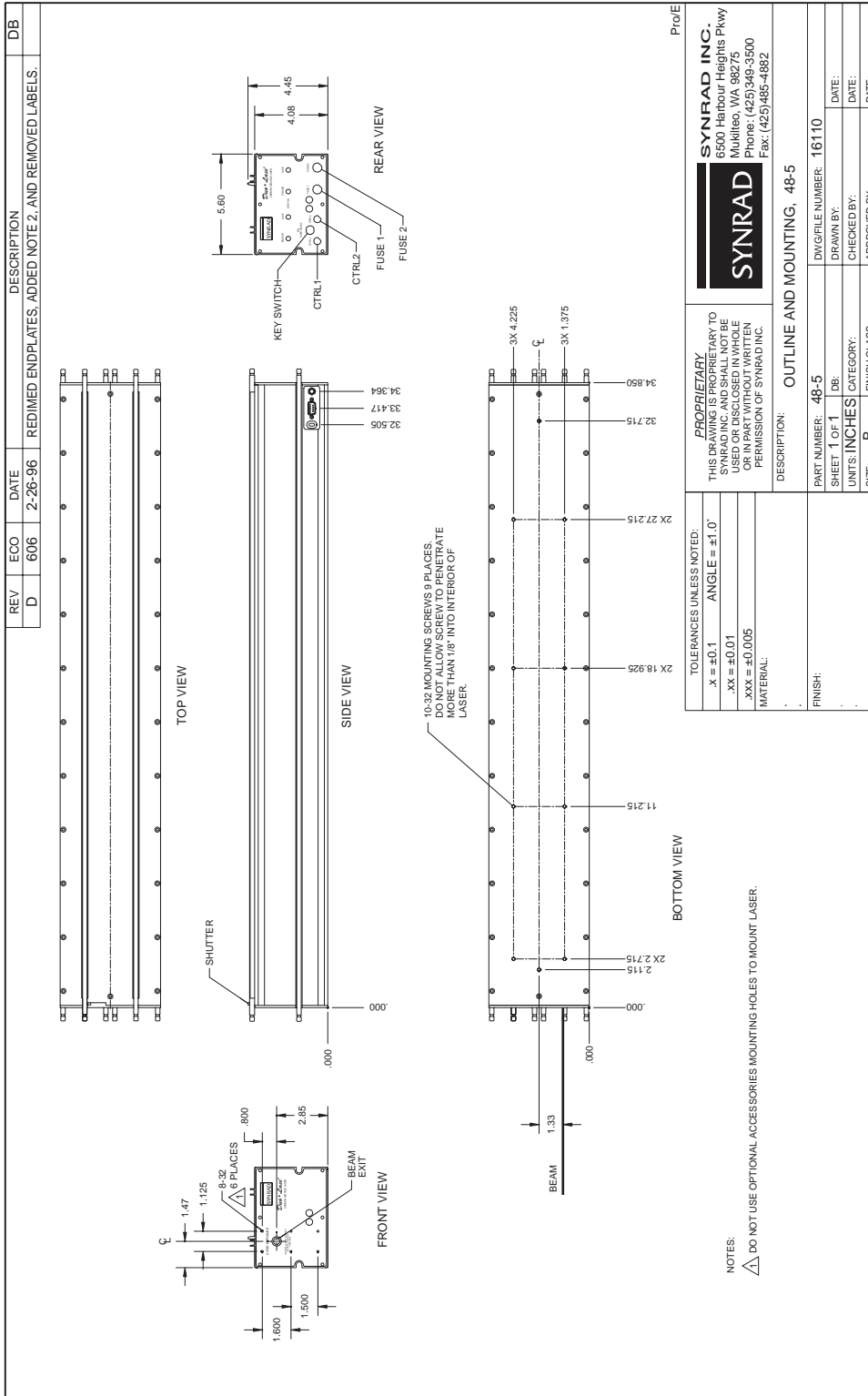

Figure 3-12 Model 48-5 package outline and mounting dimensions

maintenance/ troubleshooting

Use information in this section to perform maintenance or troubleshoot your SYNRAD Series 48 laser.

This section contains the following information:

- Maintenance – describes typical Series 48 maintenance procedures.
- Troubleshooting – explains how to troubleshoot common Series 48 problems.

maintenance/ troubleshooting

Maintenance

The *Maintenance* section includes subsections:

- Disabling the laser
- Daily inspections
- Storage/shipping

Disabling the laser

Before performing any maintenance on your SYNRAD Series 48 laser, be sure to completely disable the laser by disconnecting the laser from its DC power source.

Daily inspections

Perform the following steps daily to keep your Series 48 laser in optimum operating condition. Except for the procedures described below, no other service is required or should be attempted.

Caution

possible
equipment
damage

If you operate your laser or marking head in a dirty or dusty environment, contact SYNRAD about the risks of doing so and the precautions you can take to increase the longevity of your laser, marking head, and associated optical components.

- 1 For water-cooled lasers, inspect all cooling tubing connections for signs of leakage.
- 2 Check for signs of condensation that may indicate the cooling water temperature has been set below the dew point temperature. Condensation will damage electrical and optical components inside the laser. See *Setting coolant temperature* in the “Getting Started” section for information on preventing condensation.
- 3 Inspect beam delivery components for signs of dust or debris and clean as required. When cleaning optical surfaces, carefully follow the manufacturer’s instructions.
- 4 Visually inspect the laser’s exterior housing to ensure that all warning labels are present. Refer to Model 48-1, 48-2, or 48-5 hazard label drawings in the “Laser Safety” section for label types and locations.

Storage/shipping

When preparing your water-cooled Series 48 laser for storage or shipping, remember to drain cooling water from the laser. In cold climates any water left in the cooling system may freeze, which could damage internal components. After draining thoroughly, use compressed shop air at no more than 29 PSI (while wearing safety glasses!) to remove any residual water. When finished, cap all cooling connectors to prevent debris from entering the cooling system.

maintenance/ troubleshooting

Troubleshooting

The *Troubleshooting* section includes subsections:

- Introduction
- J48 interconnect schematic
- J48 control board schematic
- Resetting faults
- Laser faults
- Beam delivery optics

Introduction

This section is designed to help isolate problems to the module level only. Problems on circuit boards or the laser tube are not within the scope of this guide because they are not user-serviceable assemblies; do not attempt to repair them. Contact SYNRAD or a SYNRAD Authorized Distributor for repair or replacement information.

To quickly troubleshoot the Series 48 laser, it is necessary to understand the sequence of events that must happen before the laser can turn on and operate. Before you attempt to perform any service, we advise you to read the entire troubleshooting guide and review the relevant schematic diagrams. Symptoms and possible causes are highlighted by dark print and bullet points throughout this section. Information about each symptom and cause can be found in the paragraphs following each heading.

Warning

serious
personal
injury

This product emits invisible infrared laser radiation at the 10.6 μm CO₂ wavelength. Direct or diffuse laser radiation can inflict severe corneal injuries and can seriously burn human or animal tissue. Service personnel troubleshooting Series 48 lasers should be thoroughly trained in laser safety practices and electronic service techniques before attempting repairs.

Caution

possible
equipment
damage

Attempting repair of a SYNRAD Series 48 laser without the express authorization of SYNRAD, Inc. will void the product warranty. If troubleshooting or service assistance is required, please contact the SYNRAD Service Department.

maintenance/ troubleshooting

Troubleshooting

J48 interconnect schematic

Figure 4-1 shows Series 48 interconnections for all Model J48 Series lasers.

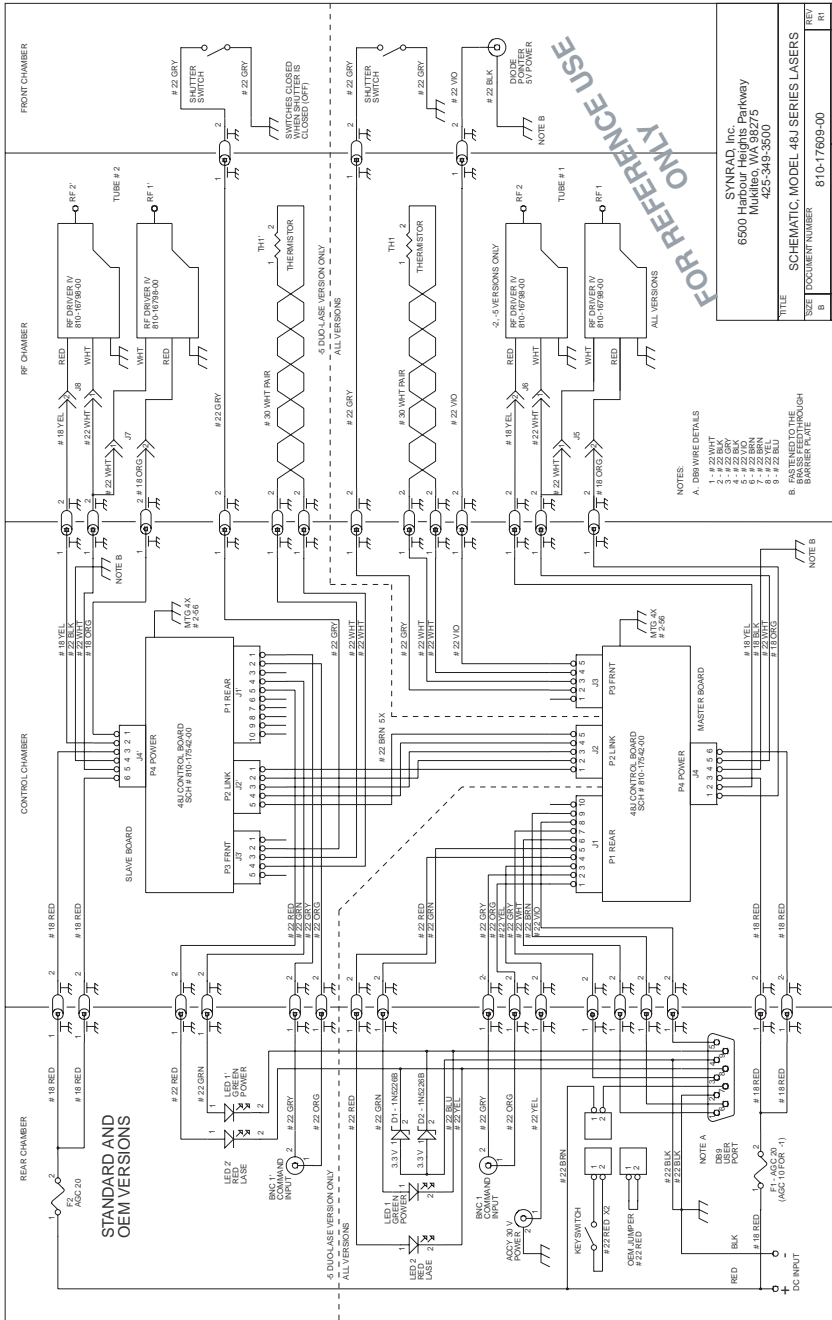

Figure 4-1 Model J48 Series interconnect schematic

maintenance/ troubleshooting

Troubleshooting

J48 control board schematic

Figure 4-2 schematically illustrates the layout of J Series control boards.

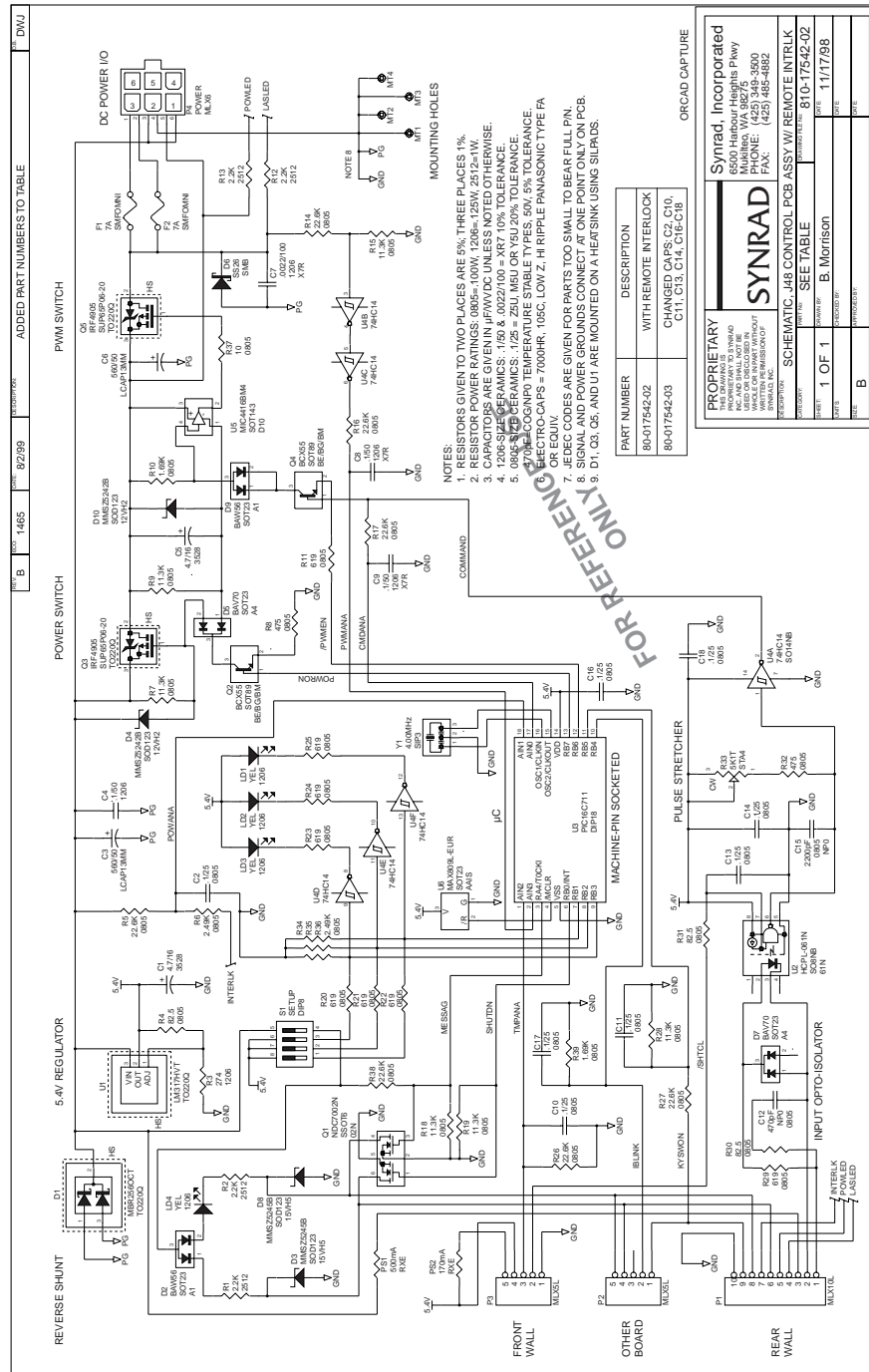

Figure 4-2 J Series control board schematic

maintenance/ troubleshooting

Troubleshooting

Resetting faults

Keyswitch lasers

On *Keyswitch* lasers, the *PWR* indicator illuminates green only when the *Remote Interlock* input is closed and the *Keyswitch* is cycled from OFF to the ON position (or the *Remote Keyswitch* input is opened and then closed). After the *PWR* indicator illuminates, a five-second delay occurs before the laser is permitted to lase. The *LASE* LED illuminates dimly when tickle pulses are applied to the laser and when PWM Command pulses are applied (and are long enough to produce laser output) the *LASE* LED illuminates and appears to brighten in relation to an increasing PWM duty cycle.

To reset a remote interlock fault after the fault condition has been cleared, the *Keyswitch* must be cycled from OFF to ON (or with the *Keyswitch* ON, cycle the *Remote Keyswitch* input open and then closed). When the *PWR* indicator illuminates, lasing is enabled after the five-second delay.

To reset an over temperature fault, lower coolant temperature below 22 °C (water-cooled) or below 40 °C (air-cooled). When the laser cools sufficiently, remove DC power for 30 seconds and then reapply power to the laser or cycle the *Keyswitch* from OFF to ON (or with the *Keyswitch* ON, cycle the *Remote Keyswitch* input open and then closed). When the *PWR* indicator illuminates, lasing is enabled after the five-second delay.

A closed shutter is not considered a fault condition; when the shutter is opened, lasing is enabled after a five-second delay provided that the *PWR* indicator is illuminated green.

OEM lasers

On OEM lasers, the *PWR* lamp illuminates on DC power-up. After the *PWR* indicator illuminates, a five-second delay occurs before the laser is permitted to lase. The *LASE* LED illuminates dimly when tickle pulses are applied to the laser and when PWM Command pulses are applied (and are long enough to produce laser output) the *LASE* LED illuminates and appears to brighten in relation to an increasing PWM duty cycle.

To reset an over temperature fault, the coolant temperature must be lowered below 22 °C (water-cooled) or below 40 °C (air-cooled). When the laser cools sufficiently, remove DC power for 30 seconds and then reapply power to the laser or toggle (open, then close) the *Remote Keyswitch* signal via pin 6 and pin 7 on the *DB9 Connector*. When the *PWR* indicator illuminates, lasing is enabled after the five-second delay.

maintenance/ troubleshooting

Troubleshooting

Laser faults

Each Symptom listed below describes a particular fault condition. For each Symptom, specific causes and solutions are described in the Possible Causes section.

Symptom:

- There is no output laser beam; *PWR* and *LASE* indicators are off.

Possible Causes:

- No DC voltage is applied or the voltage level is out of specification.

Check that +30 VDC is available on the power supply output terminals and ensure that *DC Power* cable terminal connections are tight.

Check the fuse(s) on the rear of the laser. Replace with fast-blow 10 Amp (48-1) or 20 Amp (48-2/48-5) AGC/3AG fuses as required.

If your DC-2 or DC-5 power supply is operating at an input voltage of 120 VAC, ensure that a jumper wire is connected between pins 1 and 2 on the input terminal strip. Refer to *Connecting* in the “Getting Started” section for details.

Possible Causes:

- The laser’s *DB9 Connector* is not configured correctly.

Ensure that the factory-wired DB9 jumper plug is firmly plugged into the laser’s *DB9 Connector*.

If the laser is connected through the *DB9 Connector* to external circuits, check that field wiring is correct. The remote interlock connection (pin 3) must be grounded through your external interlock circuit to pin 2 or pin 4. Pin 6 must be connected to pin 7 through your external keyswitch circuitry. Refer to *Connecting* in the “Getting Started” section and *DB9 connections* in the “Technical Reference” section for details. A quick method to isolate the problem to either the laser or the field wiring is to disconnect field wiring and plug in the factory-wired jumper plug; if the lasers operates normally with the jumper plug installed, verify external wiring and circuit devices.

Possible Causes:

- The laser’s *Keyswitch* or aperture shutter are not set properly.

Cycle the *Keyswitch* to the OFF position for a few seconds, then cycle back to ON.

Close and then re-open the *Shutter Switch*.

maintenance/ troubleshooting

Troubleshooting

Possible Causes:

- The laser is in an over temperature condition.

Allow the laser to cool. Water-cooled lasers—check for proper coolant temperature and flow rate. Air-cooled lasers—verify fan operation and check for at least 2.25" of unobstructed clearance around the fan housing. To restart the laser, disconnect DC power, wait 30 seconds, and then reapply DC power.

Symptom:

- No output beam, but the *PWR* LED is On. The *LASE* indicator is dim and does not brighten.

Possible Causes:

- A PWM Command input signal is not present.

Verify that a PWM Command signal is present on the *CTRL* input. On 48-5 dual-tube lasers, a Command signal must be applied to both *CTRL1* and *CTRL2* inputs simultaneously. See *Controlling laser power* in the “Technical Reference” section for PWM Command signal details.

Symptom:

- Laser output power is low.

Possible Causes:

- Electrical inputs are not in specification.

Check that the laser’s DC supply voltage measures +30 VDC under full load.

Symptom:

- The laser spot is not circular or does not stay circular during operation.

Possible Causes:

- The laser is overheating.

Verify that the laser is receiving the proper air or water flow per Table 4-1 below.

Table 4-1 Series 48 cooling specifications

Model	Air-cooled	Water-cooled
48-1	250 CFM × 2 fans (1 per side)	0.5 GPM, < 60 PSI
48-2	250 CFM × 4 fans (2 per side)	0.8 GPM, < 60 PSI
48-5	N/A	1.5 GPM, < 60 PSI

maintenance/ troubleshooting

Troubleshooting

Symptom:

- Laser power varies or responds intermittently to input PWM Command pulses.

Possible Causes:

- Verify that your UC-2000 or equivalent PWM controller is delivering tickle pulses of the proper duration. See *Controlling laser power* in the “Technical Reference” section for tickle pulse details.

Beam delivery optics

Symptom:

- The laser appears to slowly lose power over time; laser output power must be increased to maintain previous performance.

Possible Causes:

- Beam delivery optics are coated by vapor residue or debris.

Shut down the laser and carefully inspect each optic in the beam delivery path, including the laser’s output coupler. Remember that optics are fragile and must be handled carefully; preferably by the mounting ring only. If the optic requires cleaning, then refer to the optic manufacturer’s instructions for cleaning. Use only recommended cleaning materials to prevent scratching delicate optical surfaces.

If the focusing optic is pitted, it must be replaced. The laser’s high power density will cause pits or debris on the lens to absorb enough energy that the lens may crack. If this happens, other optics in the beam path may be contaminated or damaged as well.

When the application requires air (instead of nitrogen or argon) as an assist gas, we recommend the use of breathing quality air available in cylinders from a welding supply company. Because compressed shop air contains minute particles of oil and other contaminants that will damage optical surfaces, shop air must be carefully filtered and dried before use as a purge or assist gas. Refer to Table 3-1, *Gas purity specifications*, in the “Technical Reference” section for filtering/drying specifications.

Caution

possible
equipment
damage

If you operate your laser or marking head in a dirty or dusty environment, contact SYNRAD about the risks of doing so and precautions you can take to increase the longevity of your laser, marking head, and associated optical components.

maintenance/ troubleshooting

This page intentionally left blank.

appendix a

Use information in this section to connect and operate your Closed Loop (C/L) Stabilization Kit.

This section contains the following information:

- Introduction – explains how the closed loop kit functions.
- Safety precautions – lists laser safety precautions.
- Connecting – describes how to connect the closed loop kit to your laser and UC-2000 Controller.
- Operation – describes closed loop operation.
- Closed loop specifications – provides technical specifications for the Closed Loop Stabilization Kit.

appendix a

Closed Loop Stabilization Kit

Introduction

The Closed Loop (C/L) Stabilization Kit, available for 10 W and 25 W Series 48 lasers, must be installed and calibrated at the factory. The closed loop kit provides an effective, reliable method of stabilizing laser power output by optically sampling the beam and providing feedback to adjust the PWM duty cycle percentage of the UC-2000's output PWM Command signal.

After installation, the beam passes through an optical sampler (which replaces the standard front plate) before it exits the closed loop housing. Optical beam transmission is 92% since the sampler diverts approximately 8% of the output beam to a diffuser and thermopile detector. The detector signal is amplified and sent to the UC-2000 where the Controller generates a variable duty cycle signal to maintain constant average laser output power.

Note: Once installed and aligned on the laser, the Closed Loop Stabilization Kit becomes part of the loop response/gain parameter and must NOT be moved or adjusted. Any user modifications or adjustments will void the product warranty.

Safety precautions

Warning

possible
personal
injury

Please read these instructions carefully before using your Series 48 laser with a Closed Loop Stabilization Kit. To prevent injury to personnel or damage to your laser or CL Kit, follow all safety precautions and setup instructions as described here and in your laser's *Operator's Manual*. Safe operating practices should be exercised at all times when actively lasing to prevent exposure to direct or scattered laser radiation. Improper handling or operation may result in exposure to hazardous invisible laser radiation, damage to, or malfunction of the laser or Closed Loop Stabilization Kit. Severe burns will result from exposure to the laser beam. Always wear safety glasses with side shields to reduce the risk of damage to the eyes when operating the laser.

appendix a

Closed Loop Stabilization Kit

Connecting

Refer to Figure A-1 for an illustration showing a typical closed loop system and then perform the following steps:

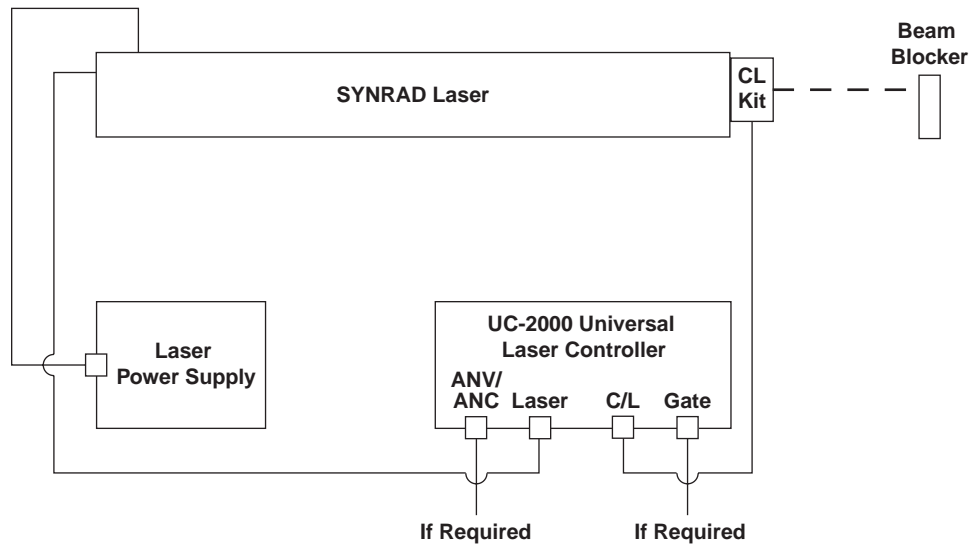

Figure A-1 Typical closed loop setup

- 1 Disconnect power from your laser and the UC-2000 Controller.
- 2 Connect one end of the *CL Interconnect* cable to the laser-mounted closed loop assembly and the other end to the UC-2000's 8-pin mini-DIN C/L connector.
- 3 If required, connect a gating signal to the UC-2000's *Gate* BNC connector.
- 4 If required, connect an ANV signal from your analog voltage source to the UC-2000's ANV/ANC BNC connector.
- 5 Set the UC-2000 to MAN. CLOSED or ANV CLOSED mode.
- 6 Apply power to both the laser and UC-2000 and then verify proper system operation.

appendix a

Closed Loop Stabilization Kit

Operation

Set the UC-2000 to MAN. CLOSED or ANV CLOSED mode. Adjust the regulated setpoint to provide a laser power output between approximately 20% and 80% of full power. This 20% window on either side of the range allows the Controller to maintain full dynamic power regulation. Within the dynamic response time of the system, the UC-2000 Controller can be gated from an external, low-frequency signal source through the *Gate* connector.

Note: When operating in either closed loop mode, power output is no longer a curve of laser output versus PWM duty cycle but instead, laser power output becomes a linear function of the desired setpoint percentage.

For the closed loop kit, servo settling time to 90% of final value occurs within approximately 2 ms. Output power regulation is typically $\pm 2\%$, even when the beam “line hops” between 10.57 and 10.63 μm .

Closed loop specifications

Table A-1 Closed loop general specifications

Parameter	Specification
Optical Transmission	92%, $\pm 1\%$
Power Input, optical	150 W maximum
Power Input, electrical	12 VDC @ 3 mA (provided by UC-2000)
Power Stability, five minutes after cold start	$\pm 2\%$
Control Range	20%–80% of rated output power
Control Frequency ¹	5 kHz
Servo Settling Time, typical	2 ms

* Specifications subject to change without notice.

¹ The Closed Loop Stabilization Kit is calibrated for operation at a PWM Command frequency of 5 kHz.

A

- Agency compliance
 - see Compliance
- Air-cooled connections 1-7
- Analog current control 1-15, 3-12
- Analog voltage control 1-15, 3-12, A-3
- Aperture
 - see Laser aperture
- Applications viii

B

- Beam attenuator 6, 9
- Beam block 7, 2-4, 2-6
- Beam characteristics 3-2, 3-4
- Beam delivery optics 2-3, 3-7 – 3-8
 - caution, 3-8, 4-9
 - inspection, 4-2
 - troubleshooting, 4-9
- Beam diameter 3-4
 - specifications, 3-18
- BNC Control cable 1-14, 1-15
 - connecting, 1-14 – 1-15

C

- Caution
 - condensation, 1-10, 1-12, 2-4, 2-6
 - coolant temperature, 1-8
 - definition, 1
 - dirty/dusty environments, 4-2, 4-9
 - laser safety, 1-2
 - optics damage, 3-8
 - radiation exposure, 2
 - tickle signal, 2-6, 3-9, 3-11
 - voiding warranty, 4-3
- CDRH requirements 6 – 7
- CE mark 8
 - label location, 3, 4, 5
- Chiller
 - connection, 1-10, 1-11
 - coolant temperature, 1-8 – 1-9, 1-11, 1-12, 4-10
 - dew point temperature, 1-9
 - fittings, 1-8
 - flow rate, 1-9, 1-11, 1-12, 2-4, 2-6, 3-18, 3-19, 4-8
 - temperature setpoint, 1-8, 1-9, 2-4, 2-6, 3-18, 3-19

Class IV safety requirements 9

- Collimators 3-8
- Command signal 2-7, 3-10 – 3-11, 4-8
 - base frequency, 3-11
 - PWM duty cycle, 3-11
 - signal amplitude, 3-10 – 3-11
- Compliance 6 – 9
 - CDRH, 6 – 7
 - Class IV safety requirements 9
 - Declaration of Conformity 10
 - EU, 8 – 9
 - FCC, 7 – 8
- Connecting 1-7 – 1-16
 - air cooling, 1-7
 - control, 1-14 – 1-15
 - DB9, 1-15
 - electrical, 1-12 – 1-14
 - water cooling, 1-8 – 1-12
 - UC-2000 Controller, 1-14 – 1-15
- Contact information viii
- Continuous wave (CW) 3-12
- Control board schematic 4-5
- Control connections 1-14 – 1-15
- Control signals 3-9 – 3-11
 - Command signal, 3-10 – 3-11
 - Pulse width modulation (PWM), 3-10
 - Tickle pulse, 3-9
- Controlling laser power 3-9 – 3-13
 - control signals, 3-9 – 3-11
 - operating modes, 3-11 – 3-13
- Controls and indicators 6, 2-2 – 2-3
 - 48-1 / 48-2 diagram, 2-2
 - 48-5 diagram, 2-3
- Cooling connections 1-7, 1-8 – 1-12
- Cooling fans
 - clearance, 1-6, 1-7, 4-8
 - recommended location, 1-7
- Cooling fittings 1-8
- Cooling kit 1-4, 1-5
 - connecting, 1-10 – 1-12
 - guidelines, 1-8
- Cooling water
 - draining, 4-2
 - flow rate, 1-9, 1-11, 1-12, 2-4, 2-6, 4-8
 - temperature setpoint, 1-8, 1-9, 1-11, 1-12, 2-4, 2-6
- Copyright information vii
- CTRL (Control) input connector 1-15, 2-2 – 2-3, 2-7, 3-4, 3-7, 3-10, 3-12, 4-8

index

Customer Service viii

D

Daily inspections 4-2

Danger
definition, 1

DB9 connections 1-15, 3-14 – 3-15, 3-16,
3-17

jumper plug, 1-15, 3-14
pinout diagram, 3-14
signal descriptions, 3-15

DB9 Connector 1-4, 1-5, 2-2, 2-4, 2-6,
3-14, 3-16, 3-17, 4-7

DC-1 DC power supply 1-12 – 1-13
AC input requirements, 1-12
connecting, 1-12 – 1-13

DC-2/DC-5 DC power supply 1-13 – 1-14,
4-7

AC input requirements, 1-12
connecting, 1-13 – 1-14

DC Power cable 1-13, 1-14, 2-3
connecting, 1-12 – 1-13, 1-13 – 1-14

DC power supply 1-12, 1-14
connecting, 1-12 – 1-13, 1-13 – 1-14
troubleshooting, 4-7, 4-8

Declaration of Conformity 10

Delivery optics 3-7 – 3-8, 4-9
caution, 3-8, 4-9

Dew point 1-8, 1-9
caution, 1-10, 1-12, 2-4, 2-6
chart, 1-9

Diode Pointer
aperture dust cover, 2-5, 2-7
power connector, 2-3

Disabling Firestar 4-2

Divergence 3-2, 3-4, 3-7 – 3-8
specifications, 3-18

Duty cycle 2-5, 2-7, 3-10, 3-11

E

Electrical connections 1-12 – 1-14

EU requirements 9

Expander/collimator 3-8

External control 3-11 – 3-12

Eye protection 1, 2-4

F

Fan clearance 1-6, 1-7, 4-8

Fault Shutdown Output 3-15

Faults

laser, 4-7 – 4-9
resetting, 4-6

FCC requirements 7 – 8
caution to the user, 8
information to the user, 7

Final Test report 1-4, 1-5

Focusing optics 3-8

Fuse 1-4, 1-5, 2-2
replacement, 4-7

G

Gas purity specifications 3-8

General hazards 1 – 2

General specifications 3-18 – 3-19

H

Hazard information 1 – 2
additional laser safety information, 2
general hazards, 1 – 2
label locations, 3, 4, 5
other hazards, 2
terminology, 1

Heat load
air-cooled, 1-7, 3-18, 3-19
water-cooled, 3-18, 3-19

I

Indicators and controls 6, 2-2 – 2-3

Initial start-up 2-4 – 2-7
with a UC-2000 Controller, 2-4 – 2-5
without a UC-2000 Controller, 2-6 – 2-7

Inspections
daily, 4-2
incoming, 1-3

Integrating safety features 3-16 – 3-17
Keyswitch functions, 3-16
Remote interlock functions, 3-17

Interconnect schematic 4-4

Interconnection diagram 1-16

Interlock
see Remote Interlock

Introduction **1-2**

Inventory **1-4 – 1-5**
contents description, **1-5**
ship kit contents, **1-4**

J

Jumper plug **1-15, 3-14, 4-7**

K

Keyswitch **6, 9, 1-2, 2-2, 2-5, 2-6, 2-7, 3-4, 3-5, 3-14, 3-15, 3-16, 3-17, 4-6, 4-7, 4-8**

Keyswitch functions
integrating, **3-16**

Keyswitch lasers
resetting, **4-6**

L

Label locations **3, 4, 5**

LASE indicator **6, 9, 2-2, 2-5, 2-7, 3-15, 4-6, 4-7, 4-8**

Laser aperture **6, 2-2, 2-4, 2-6, 3-4, 4-7**

Laser faults **4-7 – 4-9**

Laser safety information **1 – 10**

Laser tube **3-2, 3-3**

Low frequency gated operation **3-13**

M

Maintenance **4-2**
daily inspections, **4-2**
disabling the laser, **4-2**
storage/shipping, **4-2**

Marking/engraving operation **3-13**

Material Safety Data Sheets (MSDS) **2**

Message Output **3-15**

Modulation **3-4, 3-10, 3-11**

Mounting **1-6**
standard, **1-6**
with FH Series marking head, **1-6**

Mounting Rail **1-6**

N

Nomenclature **1-2**

O

OEM lasers
resetting, **4-6**

Operating modes **3-11 – 3-13**
analog current control, **3-12**
analog voltage control, **3-12**
continuous wave, **3-12**
external control, **3-11**
low frequency gated operation, **3-13**
marking/engraving operation, **3-13**

Operator's manual **1-4, 1-5**

Optical accessories mounting **2-3**

Optical output pulse
waveforms, **3-10**

Optical resonator **3-3 – 3-4**

Optical setup
cleanliness, **3-8**
delivery optics, **3-7 – 3-8**
focusing optics, **3-8**
troubleshooting, **4-9**

Optics damage **3-8, 4-9**

Outline and Mounting drawings **3-20 – 3-22**
48-1, **3-20**
48-2, **3-21**
48-5, **3-22**

P

Package outline drawings **3-20 – 3-22**
48-1, **3-20**
48-2, **3-21**
48-5, **3-22**

Packaging
guidelines, **1-3**

Pulse Width Modulation (PWM) **2-2, 2-5, 2-6, 2-7, 3-2, 3-4**
description, **3-10**

PWM Command signal **3-10, 3-11, 3-13, 4-6, 4-8**

PWR (Power) indicator **6, 9, 2-2, 2-5, 2-7, 3-15, 3-16, 3-17, 4-6, 4-7, 4-8**

R

Ready indicator
see PWR (Power) indicator

Reference materials **viii**

Remote Interlock **6, 9, 1-15, 3-14, 3-16, 3-17, 4-6**

index

Remote Interlock Connection **3-15, 3-17**

Remote Interlock functions
integrating, **3-17**

Remote Interlock signal **2-4, 2-6, 3-14, 3-15**

Remote Keyswitch **6, 9, 1-15, 2-5, 2-7, 3-4, 3-5, 3-14, 3-16, 3-17, 4-6**

Remote Keyswitch functions
integrating, **3-16**

Remote Keyswitch Input **3-15, 3-16, 3-17**

Remote Keyswitch Output **3-15, 3-16**

Remote Keyswitch signal **2-4, 2-6, 3-14, 3-15, 3-16**

Remote Lase LED Output **3-15**

Remote Ready LED Output **3-15, 3-16, 3-17**

Resetting faults **4-6**
Keyswitch lasers, **4-6**
OEM lasers, **4-6**

RF driver board **3-4, 3-5, 3-16**
schematic, **3-6**

S

Safety features **6, 8**
Class IV, **9**
integrating, **3-16 – 3-17**

Safety precautions **1 – 2**

Sales and Applications **viii**

Ship kit contents **1-4, 1-5**

Shorting plug
see Jumper Plug

Shutter Switch **6, 9, 2-2, 2-5, 2-7, 3-4, 4-7**

Signal Ground **3-15, 3-16, 3-17**

Specifications
cooling, **4-8**
gas purity, **3-8**
general, **3-18 – 3-19**

Storage/shipping **4-2**

Synrad
European headquarters, **viii**
worldwide headquarters, **viii**

System interconnection diagram **1-16**

T

Technical overview **3-2 – 3-8**
control circuitry, **3-4 – 3-6**
Duo-Lase operation, **3-7**

introduction, **3-2 – 3-3**
optical resonator, **3-3 – 3-4**
optical setup, **3-7 – 3-8**
plasma section, **3-3**

Technical support **viii**

Tickle pulse **1-14, 2-2, 2-5, 2-6, 2-7, 4-9**
caution, **3-9, 3-11**
description, **3-9**

Trademark information **vii**

Troubleshooting **4-3 – 4-9**
beam delivery optics, **4-9**
introduction, **4-3**
J48 control board schematic, **4-5**
J48 interconnect schematic, **4-4**
keyswitch faults, **4-6**
laser faults, **4-7 – 4-9**
OEM faults, **4-6**
resetting faults, **4-6**

Tubing adaptors **1-8**

U

UC-2000 Laser Controller **1-14, 1-15, 2-2, 3-9, 3-10, 3-11, 3-12, 3-13**
connecting, **1-14 – 1-15**
initial start-up, **2-4, 2-5**

Unpacking **1-3**

W

Warning
air contaminants, **2**
definition, **1**
eye protection, **1, A-2**
gate logic, **3-13**
laser output, **2-4, 4-3**
laser safety, **1, A-2**
PWM control, **1-14, 3-10**

Warranty information **vii**

Water cooling ports **1-10, 1-11**