



**SIMRAD**  
A KONGSBERG Company

MAXIMIZING YOUR PERFORMANCE AT SEA



M A N U A L

Simrad Axis  
Handheld VHF Radio

© 2004 Simrad Ltd

The technical data, information and illustrations contained in this publication were to the best of our knowledge correct at the time of going to print. We reserve the right to change specifications, equipment, installation and maintenance instructions without notice as part of our policy of continuous development and improvement.

No part of this publication may be reproduced, stored in a retrieval system or transmitted in any form, electronic or otherwise without prior permission from Simrad Ltd.

No liability can be accepted for any inaccuracies or omissions in the publication, although every care has been taken to make it as complete and accurate as possible.

# CONTENTS

## 1. GENERAL

- 1.1 Introduction
- 1.2 Technical Specification
- 1.3 Licensing

## 2. OPERATION

- 2.1 Location of Controls
- 2.2 Operation - 150
- 2.3 Operation - 200/250
  - 2.3.1 The Function Key

## 3. BATTERY USE

- 3.1 Removal, Fitting & Options
- 3.2 Charger Options
- 3.3 Mains Adaptors for Drop-In Chargers
- 3.4 Charging of Batteries
- 3.5 Notes on Charging
- 3.6 200/250 Battery Level Indicator
- 3.7 150 Battery Status LED
- 3.8 Battery Life Guidelines

## 4. ANTENNA & ACCESSORY SOCKET

- 4.1 Antenna
- 4.2 Accessory Socket (150 & 250 only)

## 5. APPENDIX

- 5.1 Spares & Accessories
- 5.2 Transmission Range
- 5.3 Frequency of Channels
- 5.4 Troubleshooting
- 5.5 Service & Warranty



## 1 GENERAL

### 1.1 Introduction

The Simrad Axis waterproof handheld VHF radio is manufactured in our modern factory facilities in the UK. The radio was designed to meet or exceed stringent International Regulations including EN301 178.

In addition Simrad GMDSS specification radios conform to Pan European specification ETS300 225 for the use of radios for Safety at Sea, including waterproofing to IP67/68 standard.

Please note that regulations vary from country to country. Simrad sets are also approved specifically by the countries in which they are sold. Consequently, there may be differences in the programming of sets bought in different countries, and therefore in their associated manuals. If using outside the country of purchase, it is vital to check that the set conforms to local regulations before use.

**Thank you for choosing Simrad.**

If you are pleased with your radio, we hope you will be interested in our range of marine electronic equipment, which is manufactured to the same high standards as Axis. Please contact your nearest Simrad Agent for a catalogue showing our increasing range of high-tech navigational instruments, autopilots and VHF radio sets.

**Simrad operate a policy of continual development and reserve the right to alter and improve the specification of their products without notice.**

**Axis® is a registered trademark of Simrad Ltd.**

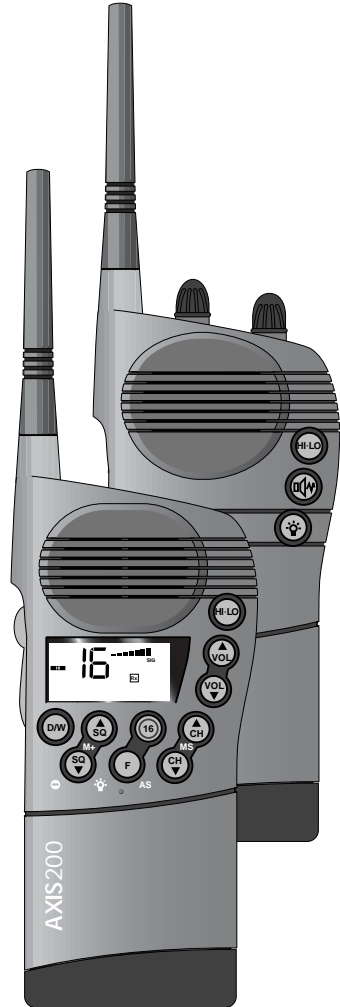

Simrad waterproof handheld VHF

## 1.2 Technical Specification

### Electrical

Channel Capability (Axis200)	55 international channels 1–28, 60–88. UK : includes M (previously 37) and M2. USA : includes 0, 29, 89, 75, 76, Wx1–10 receive only. Scandinavia : leisure or fishing channels as appropriate. Canada : Canadian and USA channels.
(250)	As 200 plus up to 16 private channels may be programmed.*
(150)	16 channel capability – channels 06, 16 and 67 are programmed as standard. Remaining channel spaces may be programmed with further international or private channels as specified. The standard channels may also be changed as required.*
(GMDSS Versions)	GMDSS sets are shipped with only simplex channels fitted.
150 GMDSS :	06, 08, 10–17, 67, 69, 71–74
250 GMDSS :	06, 08–17, 67–69, 71–77
Frequency Range	155–165Mhz (can be extended to suit market requirements)*.
Operating Temperature Range	-20°C to +60°C
Output Power	2 levels, maximum 5 Watts (1 & 5 Watts standard)*.
Harmonic and Spurious Emissions	<.25µW Tx, <1nW Rx
Sensitivity	0.5µV for 20 dB SINAD
Selectivity	75 dB (±25 kHz)
Intermodulation	75 dB
Channel Spacing	25kHz (12.5 khz also possible)*
Blocking	90dB
Spurious Response	80dB
Audio Output Power	Max 1 Watt
Current Consumption	Squelched <25mA Receive typically 125mA Transmit 5 Watts 1.4A 1 Watt 0.8A
Weight	600g (approx)

\* Contact local Simrad Service Agent for further details of channel programming, etc.

### Environmental

Waterproof	To a depth of 1m fully submersed, including a 45°C thermal shock.
Drop Resistance	Will withstand a drop from 1M on to a hard surface on any face.
Hermetically Sealed	Will withstand petrol, diesel and other fuel oils.
Ergonomics	Is designed to fit comfortably into the hand and be operated with ease in the worst weather conditions.



## 1.3 Licensing

Prior to use check the national licensing requirements for operators.

In the UK licence applications and queries should be made to the following authority:

**Ship Radio Licensing  
Radio Licencing Centre  
The Post Office  
PO Box 1495  
Bristol  
BS99 3QS  
Website: [www.radiolicensingcentre.co.uk/rlc](http://www.radiolicensingcentre.co.uk/rlc)**

A set may only be operated by or under the supervision of the holder of a *Marine Radio Operator's Certificate of Competence and Authority to Operate*. This is awarded on completion of the Marine Short Range Certificate course administered by the Royal Yachting Association:

**Royal Yachting Association  
RYA House  
Ensign Way  
Hamble  
Southampton  
SO31 4YA  
Website: [www.rya.org.uk](http://www.rya.org.uk)  
Tel. 0845 345 0400**

Holders of the *Restricted Certificate of Competence in Radio-telephony* (which covers MF/HF SSB, etc.) do not need a separate VHF certificate.

In the USA licence applications should be made to:

**Federal Communications Commission  
Gettysburg  
Washington DC 20554  
PA17325  
Website: [www.fcc.gov](http://www.fcc.gov)**

In Canada licence applications should be made to the regional or district offices of:

**Spectrum Direct®  
Industry Canada  
Website: <http://sd.ic.gc.ca/engdoc/main.jsp>**

In all other countries, please contact your regional authority for information.

## 2 OPERATION

### 2.1 Location of Controls

The location of the controls for the 150 and 200/250 are shown in Figures 2.1 and 2.2:

#### 150 –

- 1 On/Off Button
- 2 PTT Button
- 3 (Accessory Socket)
- 4 High/Low Transmit Power Button
- 5 Autosquelch On/Off Button
- 6 Backlight On/Off (Channel Display)
- 7 Channel Selection Knob
- 8 Audio Volume Control Knob
- 9 (Tx Status LED)
- 10 (Battery Status LED)
- 11 (Rx Status LED)

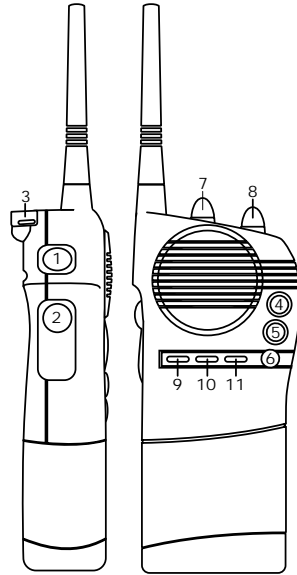

Fig 2.1 - 150 schematic

#### 200/250 –

- 1 On/Off Button
- 2 PTT Button
- 3 (LCD Screen)
- 4 High/Low Transmit Power Button
- 5 Audio Volume Up
- 6 Audio Volume Down
- 7 Dual Watch (D/W)
- 8 Squelch Up/*Enter Memory*
- 9 Channel 16
- 10 Channel Up/*Memory Scan*
- 11 Squelch Down/*Scan Inhibit*
- 12 Function\*/*LCD Backlighting*
- 13 Channel Down/*All Scan*

\* Scanning models only. All functions listed *in italics* are secondary functions accessed by pressing the **FUNCTION (F)** key first.

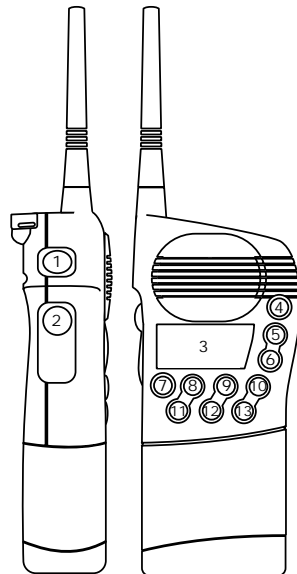

Fig 2.2 - 200/250 schematic

## 2.2 Operation – 150

The operation of any of the push buttons or the channel selector knob is confirmed by an audible beep from the unit. The operation of the controls for the 150 and 150 GMDSS is as follows:

### On/Off Button (1)

Pressing this button will turn the radio on and off. To turn the radio off it is necessary to hold the button in for two seconds. This prevents the radio being accidentally switched off.

### PTT Button (2)

The PTT, or Press-To-Talk, button is used to switch the radio from receive to transmit. Unlike other keys, the radio will not beep if this key is pressed, but the Rx LED (11) will go off and the Tx LED (9) will illuminate.

If the radio will not transmit when the PTT button is pressed, this may be because the selected channel is not valid for transmission.

### High/Low Transmit Power Button (4)

This button will toggle the transmit power between the preset maximum level (normally 5 Watts) and low power (normally 1 Watt).

### Autosquelch On/Off Button

When pressed, this button will open the squelch to incoming signals. The squelch setting is preset at the factory to cope with most operating conditions. If, however, it is found necessary to change this setting, the following procedure should be followed :

1. With the radio on, turn the volume control (8) fully anti-clockwise (Fig 2.3).
2. Turn the radio off.
3. Without adjusting the rotary controls, hold in the squelch button and turn the radio on.
4. A triple beep will be heard. This will be followed by a series of beeps indicating the squelch level being set.
5. The setting is from 1 to 8 beeps, with 8 being fully squelched. When the correct setting is reached, release the squelch button. The setting is now stored in the radio.

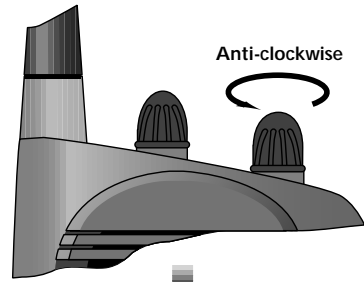

**TURN RADIO OFF**



**TURN RADIO ON**

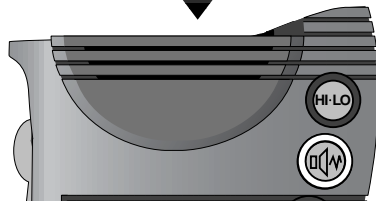

**RELEASE BUTTON WHEN CORRECT SETTING IS SELECTED**

Fig 2.3 - Setting Autosquelch

### Backlighting On/Off (6)

This button will illuminate the channel selection window for a period of ten seconds. The window will re-illuminate for a further ten seconds if a key is subsequently pressed, thus preserving battery life. Pressing this button again will switch the backlighting off.

### Channel Selection Knob (7)

This is a sixteen-position rotary switch used to select the channels programmed into the radio. The channel selected is shown in the channel selection window next to the knob, with each programmed channel selection being confirmed by a beep. This first position (normally channel 16) is indicated by a long beep. NB, although there are sixteen channel locations, not all of these may have a channel programmed into them.

### Audio Volume Control Knob (8)

Turn the knob clockwise to increase volume and anticlockwise to reduce volume.

### Tx Status LED (9)

This LED indicates the transmit power status of the radio:

<b>LED Blinking</b>	Receive, high power selected.
<b>LED Off</b>	Receive, low power selected.
<b>LED Flashing</b>	Transmit, low power selected.
<b>LED On</b>	Transmit, high power selected (Fig 2.4).

### Battery Status LED (10)

This shows the charge status of the battery -

<b>LED Off</b>	Battery charge okay.
<b>LED Blinking</b>	Battery level low (Fig 2.5).

### Rx Status LED (11)

This displays the squelch status of the radio as follows:

<b>LED Blinking</b>	Fully squelched (Fig 2.5).
<b>LED On</b>	Squelch open.



Fig 2.4 - Tx LED: transmitting on high power



Fig 2.5 - Rx LED: receiving, fully squelched

## 2.3 Operation – 200/250

The operation of any of the push buttons, or the channel selector knob is confirmed by an audible beep from the unit. The operation of the controls for the 200, 250 and 250 GMDSS is as follows -

### On/Off Button (1)

Pressing this button will turn the radio on and off (Fig 2.6). To turn the radio off it is necessary to hold the button in for two seconds, preventing the radio being accidentally switched off.

### PTT Button (2)

The PTT, or Press-To-Talk, button is used to switch the radio from receive to transmit. Unlike other keys, the radio will not beep if this key is pressed, but the LCD legend will change from **Rx** to **Tx**, and the bar graph will display the current battery strength.

If the radio will not transmit when the PTT button is pressed, this may be because the selected channel is not valid for transmission. **NOTE** - transmit is also inhibited when the Dual Watch or Scanning functions are activated.

### High/Low Transmit Power Button (4)

This button will toggle the transmit power between the preset maximum level (normally 5 Watts) and low power (normally 1 Watt). The power setting selected will be indicated by either the **HI** or **LO** legend on the LCD display.

### Audio Volume Up (5)

This button will increase the audio volume in graduated increments. The volume setting will be indicated on the LCD display by the bar graph (Fig 2.7).

### Audio Volume Down (6)

This button will decrease the audio volume in graduated decrements. The volume setting will be indicated on the LCD display by the bar graph.

### Dual Watch (7)

The Dual Watch function enables the radio to scan between the selected channel and the priority channel (normally channel 16). To activate Dual Watch mode, select the channel and press



Fig 2.6 - Switching On and Off



Fig 2.7 - Volume bargraph on LCD display

D/W. While the radio is in Dual Watch mode, the D/W legend will be displayed on the LCD.

**REVERT Function** - If D/W is pressed when CH16 is selected, the radio will revert to the previously selected channel.

### Squelch Up (8)

This button will increase the receiver muting threshold (or SQUELCH) level, i.e a stronger signal will be required to activate the receiver. The squelch level selected is indicated by the bar chart on the LCD display (Fig 2.8).

### Squelch Down (11)

This button will decrease the squelch level, i.e weaker signals will be able to activate the receiver. The squelch level selected is indicated by the bar chart on the LCD display.

### Channel 16 (9)

Will automatically select Channel 16 on High Power when pressed. Any function active (such as Dual Watch, Scanning, etc) will be cancelled.

### Channel Up (10)

This button will scroll up through the channels available, the selected channel being shown by the large digits on the LCD display (Fig 2.9). The radio will automatically switch to Low Power if the selected channel is inhibited to transmit on the Low Power setting only, even if High Power is currently selected.

### Channel Down (13)

This button will scroll down through the channels available as Channel Up (see above).

## 2.3.1 The Function Key (12)

(SCANNING MODELS ONLY) Function (F) is used to access second level functions available, and is indicated by the **F** legend appearing in the LCD display for two seconds. After this time, the legend will disappear and the radio will revert to first level functions. Therefore, the subsequent buttons must be pressed within two seconds of F being pressed.



Fig 2.8 - Squelch bargraph on LCD display



Fig 2.9 - Scrolling through channels using CH▲ and CH▼ buttons

**NOTE** - Second level functions are only available on scanning versions of the 200 and 250. On non-scanning versions, the F key is replaced with a backlighting key.

## ☼ - Backlighting (F-F)

On scanning models of the 200 and 250, the LCD display backlighting can be switched on by pressing F and F again within two seconds. By keeping F depressed, the radio will step through the six levels of illumination available (Fig 2.10). A second press will turn the backlighting off.

On non-scanning versions, the backlighting key ☼ – which replaces the F key – must only be pressed and held once.

While the backlighting is activated, the lamp legend ☼ will be shown on the LCD display. On all versions, the backlighting will automatically switch off if no button is pressed for ten seconds or longer. The backlighting will re-illuminate if a button is subsequently pressed.



Fig 2.10 - LCD backlighting

## AS - All Channel Scan (F-Channel Down)

This function enables the radio to scan through each channel sequentially until a signal is detected which is above the squelch level set. Once the signal ends or drops below the squelch level, the radio will continue scanning. Pressing Channel Up will step to the next channel regardless of the signal strength. Pressing Channel Down or F-Channel Down will exit Scan mode.

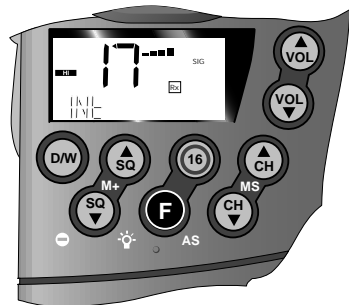

## M+ - Memory Enter (F-Squelch Up)

This function will add the currently selected channel into the Scan Memory. The LCD display will show 'ENT' indicating that the channel has been entered into the Scan Memory. When that channel is subsequently selected, a □ legend will be shown on the bottom line of the LCD display indicating that the channel is in the Scan Memory (Fig 2.11). Pressing F-Squelch Up if the channel is already in the Scan Memory will remove it from the memory - indicated by 'DEL' appearing on the bottom line of the LCD display.



Fig 2.11 - Entering channel into Scan Memory

## MS - Memory Scan (F-Channel Up)

This function operates in the same way as the Scanning function (**F-Channel Down**), except that it will only scan channels that have been entered into the Scan Memory. If no channels have been entered into the memory, then this function will not be available.

## ☐ - Channel Inhibit (F-Squelch Down)

Since the Scanning function operates by stopping on channels where a signal is detected, the function will lock onto a channel with a lot of interference noise, or if a channel is transmitting a continuous carrier wave signal. This will prevent the radio from continuing its scan of the other channels.

The Inhibit function allows unwanted channels to be removed from the Scanning function while remaining available for use on the radio. Pressing **F-Squelch Down** will inhibit the current channel - indicated by 'INH' appearing on the bottom line of the LCD display (Fig 2.12). When that channel is subsequently selected, a - legend will be shown on the bottom line of the LCD display indicating that the channel is inhibited from the Scanning function.

Pressing **F-Squelch Down** if the channel is already in inhibited will restore it to the Scan function - indicated by 'SCAN' appearing on the bottom line of the LCD display.

## Mem (F-Channel Up held for two seconds)

This function allows the radio to operate only on the channels held in the Scan Memory - indicated by 'MEM' shown on the LCD display. If the Scanning function is selected, it will operate the same way as the Memory Scan function.

Pressing **CH16** or **F-Channel Up** held for two seconds will return the radio to normal operation.

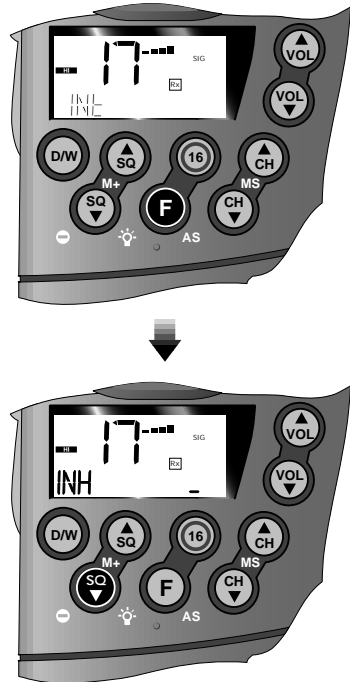

Fig 2.12 - Inhibiting channel from Scan



## 3 BATTERY USE

### 3.1 Removal, Fitting and Options

The radio comes equipped with a 700- or 850mA-hour NiCad battery pack as standard (depending on model). All battery types are housed in an identical enclosure.

Model	Battery Pack Supplied
200	NCB700 - 700mAh
150	NCB850 - 850mAh
250	NCB850 - 850mAh
150 GMDSS	NCB850 - 850mAh
250 GMDSS	NCB850 - 850mAh

To remove the battery, lift the release lever situated at the base of the battery pack to the vertical position. Turn this through 180°, and pull the release lever to withdraw the battery (Fig 3.1).

Before inserting a battery, check that the release lever is in the 'unlocked' position (Fig 3.2), i.e. the textured side of the lever is pointing away from the recess on the base of the battery pack.

Although the set is fully waterproof even with the battery removed, it is recommended that any moisture on the top of the battery or in the battery compartment is wiped clear prior to insertion to prevent the water creating a conductive path between the contacts and reducing battery life.

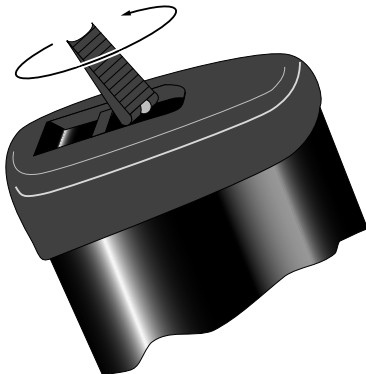

Fig 3.2 - Release lever in 'unlocked' position

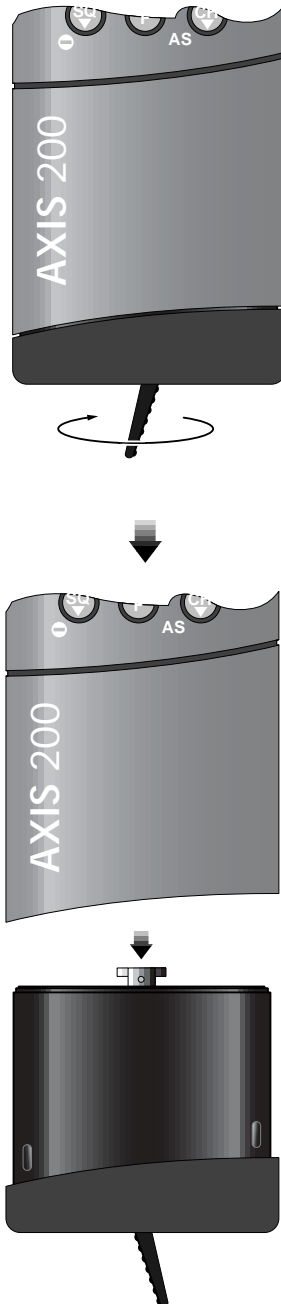

Fig 3.1 - Battery pack removal

### 3.2 Charger Options

The 200 is supplied as standard with a 12v drop-in trickle charger TCH12 that will accept the whole radio, or the battery alone (Fig 3.3). This charger will run from a standard 12v marine supply (12.6v–15.5v), or from 110v/220v/240v mains with an appropriate optional adapter/power supply. Charging with the trickle charger takes approximately 12–16 hours. There are also optional drop-in Commercial Trickle and Rapid chargers available (CTC1 and CRC1). The CRC1 will charge the battery within 1½ hours and has an additional charge maintaining slot. Both the CTC1 and CRC1 have an inbuilt mains adapter.

### 3.3 Mains Adapters for TCH12 Charger

Charger	Country	Mains Adapter
TCH12	UK	MAD230:U
	Europe	MAD230:E
	USA	MAD115:A

### 3.4 Charging of Batteries

To charge the NiCad battery pack, insert the radio or battery into the charger ensuring that excess moisture is wiped clear from the three contacts on the back of the battery pack (Fig 3.4). The TCH12 will constantly trickle charge the battery even once it is fully charged, thus ensuring that it is always at full capacity. The RCH1 will rapid charge the battery until it is fully charged and will then automatically switch to trickle charge.

**IMPORTANT – The lithium battery pack (available with GMDSS sets, or as an optional extra) are not rechargeable, and under no circumstances should any attempt be made to recharge these batteries.**

Replacement lithium cells can be re-ordered from your local Simrad Agent, quoting Part No. LTB1.



Fig 3.3 - Battery Charger Options

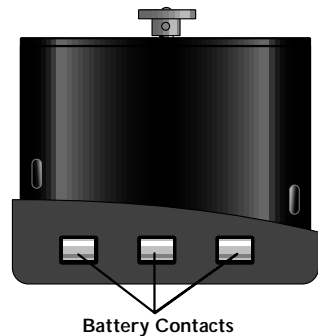

Fig 3.4 - Battery Charging Contacts

## 3.5 Notes on Charging

1. NiCad battery packs are supplied uncharged and need charging before use.
2. Charge the battery up to full charge when not in use, although it may lose a proportion of its charge after some months of storage.
3. Do not charge at temperatures below 0°C or above 40°C.
4. Check battery level indicator during switch on to determine remaining battery life.
5. Turn off if charging battery while fitted to Axis.
6. Always try to fully discharge the battery before recharging – repeated recharging of the battery while it is partly discharged may create a ‘memory effect’, preventing the battery reaching full charge.
7. Dispose of used batteries carefully. The contents of the batteries are harmful to wildlife.
8. Never expose to a naked flame.

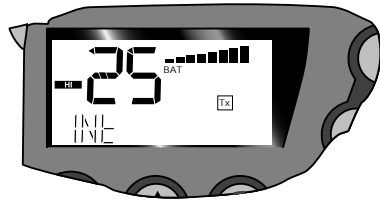

Fig 3.5 - 200/250 Battery Level Indicator

## 3.6 200/250 Battery Level Indicator

The battery level is shown when the radio is first switched on, and also when transmitting (Fig 3.5). This indicates the voltage at the battery terminals, not necessarily the charge stored. Seven or eight bars represent a fully charged battery, whilst four bars represent a battery whose charge is almost drained.

## 3.7 150 Battery Status LED

The battery status LED displays the current condition of the battery.

- LED off : Battery level nominal.
- LED blinking : Battery level low.

**NOTE** - When using a lithium battery pack, the low level battery indicator may flash under transmit conditions. This does not necessarily reflect the charge level remaining in the battery, as it is due to the different voltage characteristics of a lithium battery pack under load.

Replacement and spare batteries are available from your local Simrad Agent. Please quote the relevant part number.



Fig 3.6 - 150 Battery Status LED

### 3.8 Battery Life Guidelines

To a large extent, the battery life will depend on the usage, or Duty Cycle of the radio – i.e the battery will be drained much quicker, if the radio is transmitting continually than if it is just receiving. Additionally, if the radio is set to High Power (5 Watts\*), the power drain will be considerably greater than if transmitting on Low Power (1 Watt\*).

\* Standard power settings

BATTERY PACK	Typical Life of a fully charged pack at 25°C		
	Duty Cycle Ai	Duty Cycle Aii	Duty Cycle B
700mAh	5.6 hrs	6.7 hrs	3.2 hrs
850 mAh	8.0 hrs	9.4 hrs	4.6 hrs
Lithium	> 15 hrs	> 18 hrs	>8 hrs

- Ai** Based on - 5% Transmit at 5 Watts setting of r.f. output power (1.4Amp)  
 5% Receive at 250mWatts Audio (.25Amp)  
 90% Receiver squelched (0.025Amp)
- Aii** Based on - 5% Transmit at 1Watt setting of r.f. output power (1.1Amp)  
 5% Receive at 250mWatts Audio (.25Amp)  
 90% Receiver squelched (0.025Amp)
- B** Based on - 10% Transmit at 5Watt setting of r.f. output power (1.4Amp)  
 10% Receive at 250mWatts Audio (.25Amp)  
 80% Receiver squelched (0.025Amp)

### Charge Held While Stored

The following data is approximate:

Battery Pack		Duration	
		At 25 °C	At 45°C
NiCad Battery (NCB700/ NCB850)	Up to 50% Charge	4–6 months	4 weeks

## 4 ANTENNA & ACCESSORY SOCKET

### 4.1 Antenna

The antenna for the radio is fitted to the unit via a robust screw fitting to an M8 threaded socket on the top of the radio (Fig 4.1). This system is more rugged than a traditional BNC connector, so the radio's drop-proof integrity is not compromised by the antenna fixing.

While the radio is drop-proof and very robust, damage to the antenna such as bending or kinking may adversely affect the transmission efficiency of the unit, which may lead to overloading of the power module. Damaged antennae should be replaced immediately.

Replacement antennae can be purchased from authorised Simrad Service Agents. A full list is supplied with this unit. Please refer to section 5.1 for more details on spare parts and accessories available.

### 4.2 Accessory Socket (150 & 250 only)

Commercial and GMDSS versions of the radio (150, 250) have an accessory socket fitted behind the antenna housing (Fig 4.2). This socket will accept approved accessories such as waterproof fistmikes and headsets.

The accessory socket is waterproof, but it has an additional splash cover to protect the electrical contacts from prolonged exposure to moisture. Always replace the cover when the socket is not in use. A coating of silicone or Teflon grease to the socket is recommended to assist in protecting the contacts from moisture.

Always turn the radio off before plugging any accessory into the socket. It is recommended that any excess moisture is wiped away to avoid any problems caused by water shorting out adjacent contacts.

**NOTE - The use of unapproved accessories with the accessory socket may damage the radio and invalidate the warranty.**

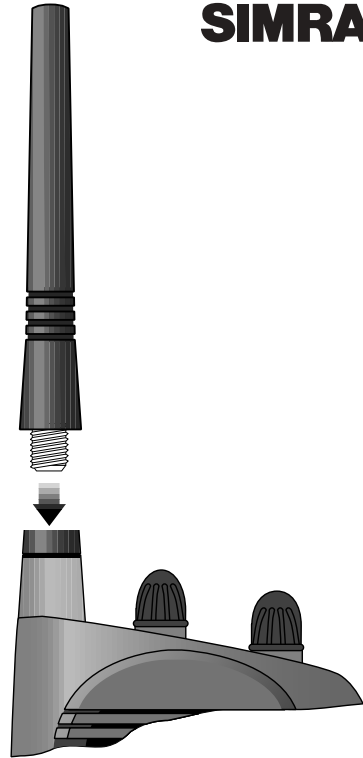

Fig 4.1 - Antenna fixing

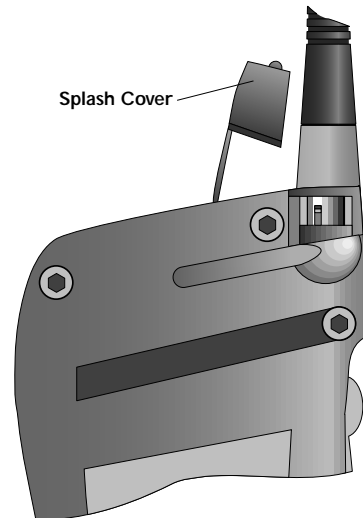

Fig 4.2 - Accessory socket (150/250 only)

## 5 APPENDIX

### 5.1 Spares & Accessories

The following spares and accessories are available from authorised Simrad Dealers. A list of dealers is included with this unit. Please quote the appropriate part number when ordering.

#### ANT1

Spare Antenna



#### NCB700

Spare NiCad Battery Pack (700mAh)

#### LTB1

Spare Lithium Battery Pack

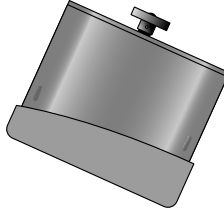

#### NCB850

Spare NiCad Battery Pack (850mAh)



### Charging Accessories

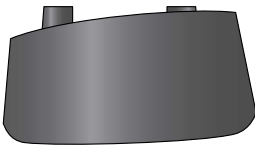

#### TCH12

12v Trickle Charger

MAD230:U (UK)  
MAD230:E (Europe)  
MAD115:A (USA)  
Mains Adapters for  
TCH12

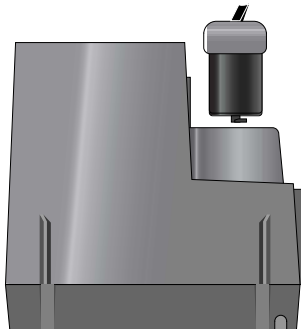
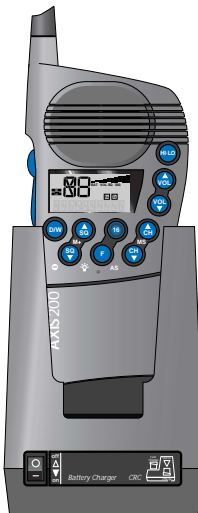
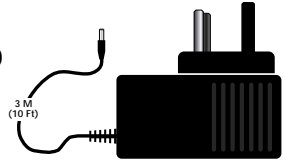

#### CTC1

Commercial Trickle Charger

#### CRC1

Commercial Rapid Charger

## Carrying Accessories

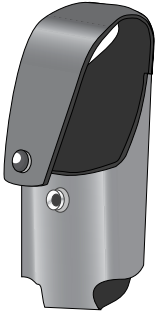

**LC1**  
Leather  
Carrying  
Case



**LYD1**  
Lanyard



**SS1**  
Shoulder  
Strap

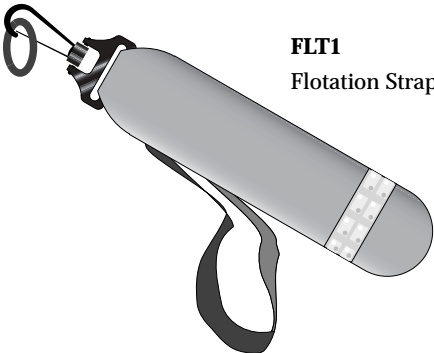

**FLT1**  
Flotation Strap

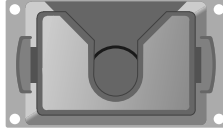

**BMT1**  
Bulkhead  
Mount Plate



**ADP1**  
Adapter Plate



**HS1**  
Handstrap



**BCP1**  
Leather Belt  
Clip c/w  
Adapter Plate  
ADP1

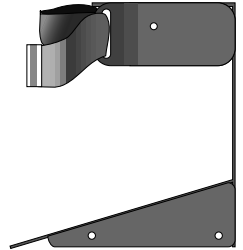

**WB1**  
Aluminium Wall  
Mount Bracket  
(For use with  
TCH12)

**WPSM1:GY**  
Waterproof Speaker  
Mike - Grey

**WPSM1:Y**  
Waterproof Speaker  
Mike - Yellow

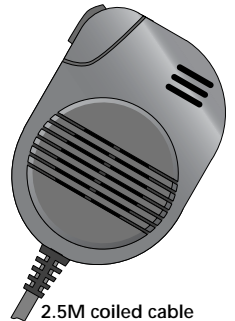

2.5M coiled cable

## 5.2 Transmission Range

Because VHF signals travel in a straight line and are not reflected back off the ionosphere as lower frequency signals are, the range of VHF signals is limited to 'line of sight', beyond which the other vessel passes behind the curve of the Earth. Therefore, the range will increase greatly the higher above sea level the antenna is, as Figure 5.1 illustrates (assuming maximum transmission power is used):

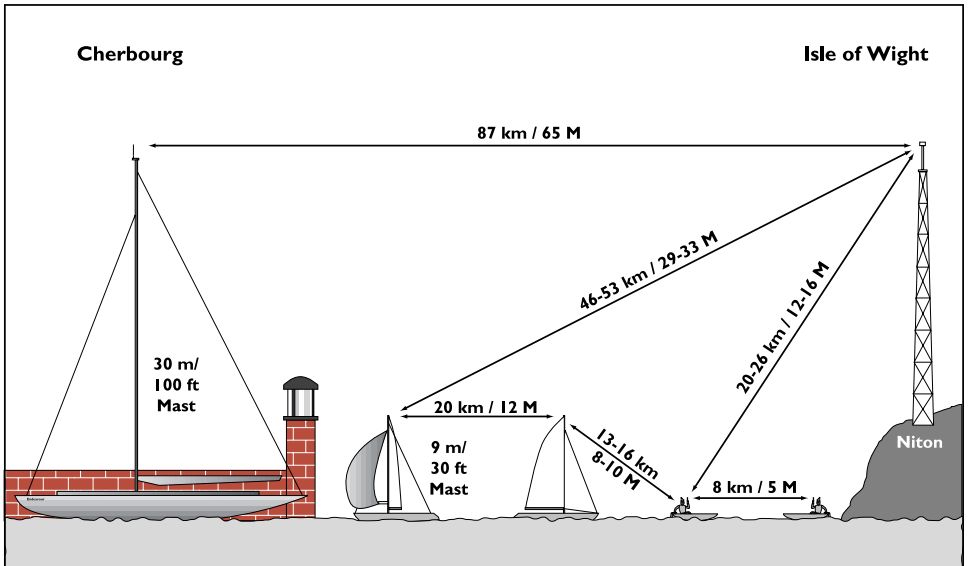

Fig 5.1 - VHF transmission range

Therefore, the typical range of a handheld radio such as this one used at sea level will be approx. 8 km (5 miles). This will increase as height above sea level increases, or if the other radio user's antenna is at a greater height – note, that the range between the yacht with the antenna mounted on a 9 m (30 ft) mast and the handheld user increases to 13-16 km (8-10 miles).



## 5.3 Frequency of Channels

Channel Designators	Tx	INT Rx	USA Rx
0	156.000	156.000	156.000
60	156.025	160.625	156.025
01	156.050	160.650	156.050
61	156.075	160.675	156.075
02	156.100	160.700	156.100
62	156.125	160.725	156.125
03	156.150	160.750	156.150
63	156.175	160.775	156.175
04	156.200	160.800	156.200
64	156.225	160.825	156.225
05	156.250	160.850	156.250
65	156.275	160.875	156.275
06	156.300	156.300	156.300
66	156.325	160.925	156.325
07	156.350	160.950	156.350
67	156.375	156.375	156.375
08	156.400	156.400	156.400
68	156.425	156.425	156.425
09	156.450	156.450	156.450
69	156.475	156.475	156.475
10	156.500	156.500	156.500
70	156.525	156.525	156.525
11	156.550	156.550	156.550
71	156.575	156.575	156.575
12	156.600	156.600	156.600
72	156.625	156.625	156.625
13	156.650	156.650	156.650
73	156.675	156.675	156.675
14	156.700	156.700	156.700
74	156.725	156.725	156.725
15	156.750	156.750	156.750
75	156.775	156.775	156.775
16	156.800	156.800	156.800
76	156.825	156.825	156.825
17	156.850	156.850	156.850
77	156.875	156.875	156.875

Channel Designators	Tx	INT Rx	USA Rx
18	156.900	161.500	156.900
78	156.925	161.525	156.925
19	156.950	161.550	156.950
79	156.975	161.575	156.975
20	157.000	161.600	161.600
80	157.025	161.625	157.025
21	157.050	161.650	157.050
81	157.075	161.675	157.075
22	157.100	161.700	157.100
82	157.125	161.725	157.125
23	157.150	161.750	157.150
83	157.175	161.775	157.175
24	157.200	161.800	161.800
84	157.225	161.825	161.825
25	157.250	161.850	161.850
85	157.275	161.875	161.875
26	157.300	161.900	161.900
86	157.325	161.925	161.925
27	157.350	161.950	161.950
87	157.375	157.375	157.375
28	157.400	162.000	162.000
88	157.425	157.425	157.425
29	–	–	157.450
89	–	–	157.475
WX01	–	–	162.550
WX02	–	–	162.400
WX03	–	–	162.475
WX04	–	–	162.425
WX05	–	–	162.450
WX06	–	–	162.500
WX07	–	–	162.525
WX08	–	–	161.650
WX09	–	–	161.775
WX10	–	–	163.275

Note: Duplex channels are marked in grey.

Designation	Tx	Rx	Country
M	157.850	157.850	UK
M2	161.425	161.425	UK
31	157.550	161.150	Holland / Belgium
96	162.425	162.425	Belgium
L1/1L	155.500	155.500	Scandinavia
L2/2L	155.525	155.525	Scandinavia
L3/3L	155.650	155.650	Scandinavia (not Denmark)
F1/1F	155.625	155.625	Scandinavia
F2/2F	155.775	155.775	Scandinavia
F3/3F	155.825	155.825	Scandinavia

The supplementary table (see left) lists further channels, which may be fitted to your radio. These are only licensed for use in the countries indicated. No attempt should be made to use them in any other country.

In the UK channels 0 and 00 will only be made available to Coastguard users with written authorisation.

## 5.4 Troubleshooting

Symptom	Possible Cause	Remedy
Unit will not switch on	* Battery not charged * Battery not secured correctly in radio	* Re-charge battery * Ensure battery is fully locked in (see section 3.1)
Scan or Memory Scan is locking on a channel without a signal	* Noise on the channel is holding the scan	* Increase squelch level * Inhibit channel from scan - 200/250 (see section 2.3)
Dual Watch not being entered	* Priority channel selected (normally CH16)	* Select a working channel
Cannot change channel	* Dual Watch (D/W) engaged	* Exit Dual Watch
Certain channel numbers are not obtainable	* Some channels are restricted and programmed out depending on country of purchase	* Consult your national authority for permitted channels in your region
Will not transmit	* Scanning or D/W function active	* Exit D/W or Scan
Will not transmit on 5W but OK on 1W	* Low voltage when full transmitting current is drawn * Some channels are restricted to low power transmission only	* Battery charge low - recharge the battery * Consult your national authority
Transmissions persistently weak	* Damaged antenna	* Replace antenna

These simple checks should be carried out before seeking technical assistance and may save time and expense.

Before contacting your servicing agent please obtain the radio's serial number. On 200 & 250 models the software iteration should also be quoted. This is shown in the large digits on the display for 2 seconds after the radio is turned on.

## 5.5 Service & Warranty

Your radio should seldom need servicing, although it will benefit from an application of silicone or Teflon grease to the battery contacts and accessory socket each season. If it is necessary to have the unit repaired, the warranty card supplied with the unit should have been filled in and sent to Simrad when the unit was purchased. Please refer to the Warranty Card booklet for more details.

**IMPORTANT – The radio is a sealed waterproof unit. To create and maintain its waterproof integrity it was assembled in a controlled environment using special equipment. The radio is not a user maintainable unit, and UNDER NO CIRCUMSTANCES should the unit be opened, except by authorised Simrad Service Agents. Unauthorised opening of the unit will invalidate the warranty.**





[www.simrad.com](http://www.simrad.com)

**SIMRAD**  
A KONGSBERG Company

MAXIMIZING YOUR PERFORMANCE AT SEA