

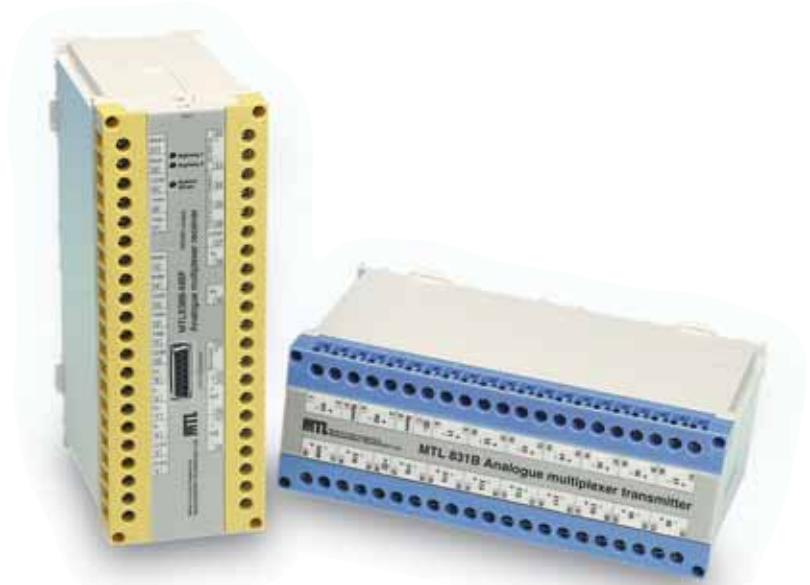

Cuts installation and cable costs for all IS hazardous-area circuits

MTL830 SERIES



- ◆ Reduce the cost of installing hazardous-area cabling
- ◆ Save installation time, space and weight
- ◆ Highlight problems quickly with status reporting systems
- ◆ Protect the process with sensor failure detection and safety drives
- ◆ Connect directly to host systems through serial-data outputs
- ◆ Analogue inputs to controllers with Modbus® communications
- ◆ Redundant data highways

MTL830 Series multiplexers with Modbus® outputs provide a cost-effective alternative to single-loop isolation. The cost of installed wiring is reduced by up to 50% by communicating the input of multiple hazardous-area sensors over dual-redundant data highways. Further savings are achieved by reducing the number of inputs to the host, cabinet space and weight.

A **multiplexer transmitter**, mounted in the hazardous area, caters for thermocouple, RTD and mV analogue inputs. A compatible safe-area receiver provides serial Modbus® outputs for feeding to host PLC, PC or DCS controllers.

Dual-redundant data highways between the transmitter and the receiver allow continuous normal operation with only one highway connected. The highway cable, a simple twisted pair or a pair of wires within an IS multi-core cable, carries both power and data, over distances up to 2km. If the multiplexer transmitter is located in the hazardous area, each data highway must be protected by an MTL3052 digital isolator.

Multiplexer systems can communicate the status of up to 32 inputs, reducing the number of hazardous area wiring pairs from 32 to two.

Reduce costs by eliminating long runs of expensive thermocouple compensation cable from the hazardous to the safe area. Also, if 3- or 4-wire RTDs are used, costs are reduced by terminating each RTD at the transmitter or its enclosure.

Dual redundant highways increase system reliability. Failure detectors and safety drives protect against the consequences of sensor failure, while built-in systems report failures to the host controller.

Accessories include steel and stainless-steel enclosures, earth-leakage detectors and a PC-based configuration software package.

For more information see AN9010, 'A user's guide to multiplexers' and TP1098, 'Cut the cost of intrinsic safety – by multiplexing!'



EUROPE (EMEA)
AMERICAS
ASIA PACIFIC
E-mail: enquiry@mtl-inst.com

Tel: +44 (0)1582 723633
Tel: +1 603 926 0090
Tel: +65 487 7887

Fax: +44 (0)1582 422283
Fax: +1 603 926 1899
Fax: +65 487 7997

Web site: www.mtl-inst.com

May 2004

MTL831B MULTIPLEXER TRANSMITTER



MTL831B multiplexer transmitters are normally sited in the hazardous area. They are connected to sensors in the field and communicate these inputs to the safe area via single-pair data highways. The data highways support communication between the safe and hazardous areas, and also provide power to the transmitters – no additional field power is required.

The MTL831B would typically be mounted close to the field instruments in an enclosure such as the ENC8 or ENC83 (see 'MTL800 Series Enclosures').

MTL831B ANALOGUE INPUT TRANSMITTER

Monitors inputs from up to 16 THC or millivolt sources (max $\pm 60\text{mV}$) or up to 15 2-, 3- or 4-wire RTDs within a hazardous area.

- ◆ Intrinsically safe; Zone 0 location
- ◆ Communication and power pass over twin data highways
- ◆ Powered by the data highway
- ◆ Thermocouples and RTDs may be mixed on one transmitter

MULTI-DROPPING TWO MTL831BS

Two MTL831B multiplexer transmitters can share the same single-pair highway to a single safe-area isolator/receiver combination, providing up to 32 multiplexed inputs.

DATA HIGHWAY CABLING

Cabling with low capacitance and resistance is recommended to achieve greater distances between transmitters and receivers. See cable parameters in 'Basic Specifications' for specific requirements, and contact MTL for latest cable recommendations. The system is designed to use both data highways, although it can be used with only one data highway in place. However, use of a single highway will increase response time.

Data highway lengths of up to 2km in hazardous areas and 3km in safe areas have been achieved.

ENCLOSURES

A range of steel and stainless steel enclosures is available for mounting MTL831B units in the field (see 'MTL800 Series Enclosures'). ENC8 and ENC8SS (stainless steel) enclosures provide protection for a single MTL831B. The enclosures are dust-tight and waterproof to IP67.

When using 4-wire RTDs, ENC83 and ENC83SS (stainless steel) enclosures provide additional terminals to accommodate the third and fourth RTD wires, which are not connected to the MTL831B itself.

MTL838B-MBF RECEIVERS



MTL838B-MBF receivers translate the information transmitted from the MTL831B via the data highway. The MTL838B-MBF provides a Modbus[®] serial-data output representation of the inputs together with status information.

MTL838B-MBF MODBUS[®] ANALOGUE RECEIVER

Translates data received from the MTL831B in the hazardous area and makes it available as twin RS485 Modbus[®] serial data outputs. The MTL838B-MBF is configured by personal computer for thermocouple and RTD type, safety drive, high and low alarm and any other operational parameters.

MTL3052 DATA HIGHWAY ISOLATOR

An MTL3052 isolator is required for each data highway, when the transmitter is located in a hazardous area. It is not required for safe-area applications.

MULTI-DROPPING MODBUS[®] RECEIVERS

Up to 31 Modbus receivers can be multi-dropped on a single RS485 link to the host system. Modbus[®] receivers can be controlled by any suitable Modbus[®] master. The receivers may be used with other Modbus[®] slaves on the same RS485 link.



MTL830 SERIES MULTIPLEXER SYSTEM DIAGRAM

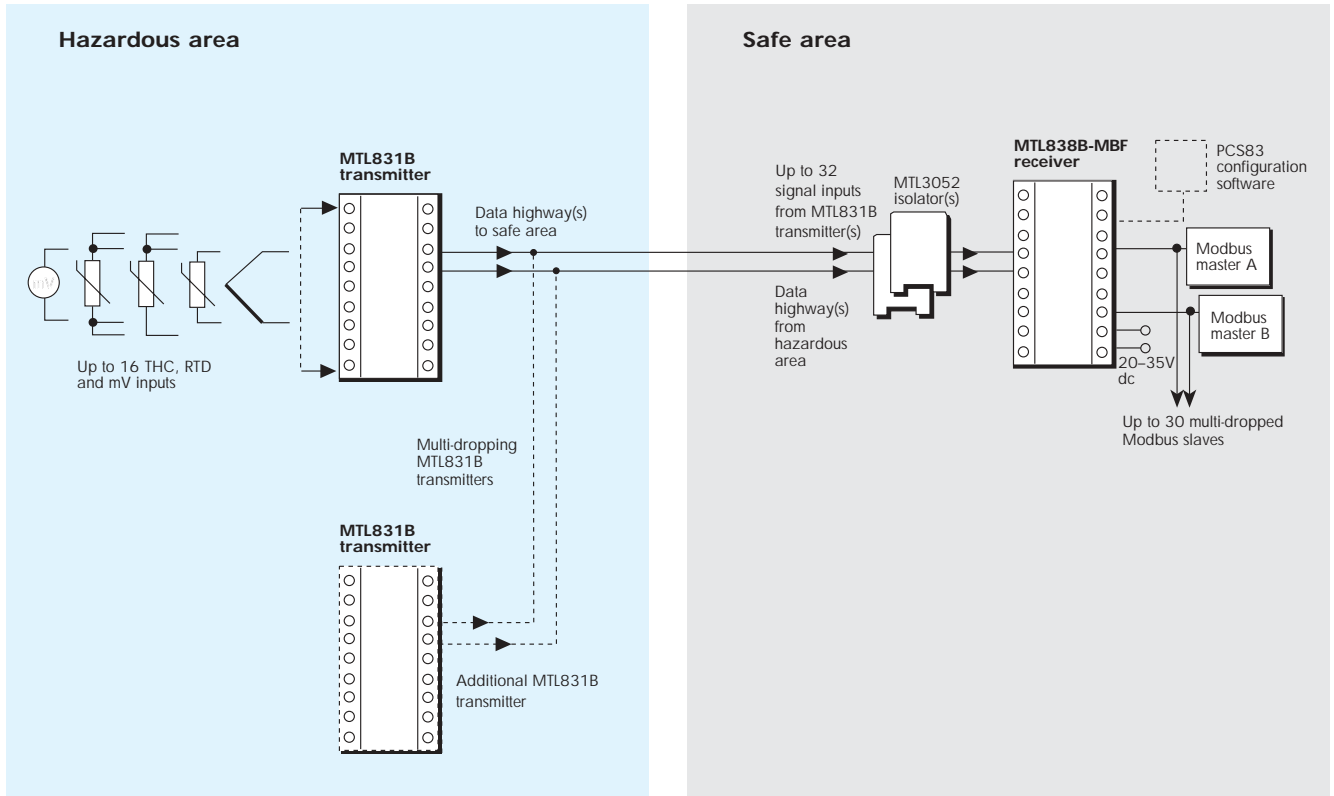

EUROPE (EMEA)
AMERICAS
ASIA PACIFIC
E-mail: enquiry@mtl-inst.com

Tel: +44 (0)1582 723633
Tel: +1 603 926 0090
Tel: +65 487 7887

Fax: +44 (0)1582 422283
Fax: +1 603 926 1899
Fax: +65 487 7997

Web site: www.mtl-inst.com

MTL831B TRANSMITTERS

BASIC SPECIFICATIONS

(see also 'Common specification')

Number of input channels

(IS segregated and fully floating when used with MTL3052)

Location of input sources

Location of unit

Number of data highways

Power requirement

Multi-transmitter facility

Ambient temperature limits

Weight

Typical response time

(input to receiver output)

Electrical safety (each input circuit)

Input sensor cable parameters

BASEEFA values (C,L or L/R)

(IIC)

(IIB)

(IIA)

Electrical safety (data highway circuit[s]) maximum input parameters

Cable parameters (data highway circuits, each highway)

BASEEFA values (C,L or L/R)

(IIC)

(IIB)

(IIA)

MTL831B (mV input)

16 THC or mV sources, potentiometer inputs up to 1k Ω
15 (RTD or mixed)

Zone 0, IIC, T4

Zone 0, IIC, T4

Dual redundant (either or both)

Loop-powered through data highway from receiver

No hazardous-area power supply required

1 or 2

-20 to +60°C working

-40 to +80°C storage

1.3kg

1s for each transmitter

U_{max:out} = 15V

I_{max:out} = 16.3mA

W_{max:out} = 60mW

0.8 μ F, 120mH or 505 μ H/ Ω

2.4 μ F, 360mH or 1515 μ H/ Ω

6.4 μ F, 960mH or 4040 μ H/ Ω

U_{max:in} = 30V

I_{max:in} = 300mA

W_{max:in} = 1.2W

C_{eq} = 0, L_{eq} = 0

0.75 μ F, 5.2mH or 109 μ H/ Ω

2.25 μ F, 15.6mH or 327 μ H/ Ω

6.00 μ F, 41.6mH or 827 μ H/ Ω

ADDITIONAL SPECIFICATIONS

MTL831B

Each input terminal block is user-selectable by switch for mixed mV, THC, 2- or 4-wire RTD input or 3-wire RTD input.

Measuring ranges

\pm 60mV or \pm 25mV or \pm 10mV, auto ranging

Common mode voltage

Maximum 5V common mode between input channels of one transmitter

mV signals

Accuracy at 20°C (including non-linearity and hysteresis)

<0.1% of measuring range

Temperature effects on accuracy

{(greater of 0.01% of range or 2 μ V) + 0.01% of reading} /°C

Thermocouple signals

Accuracy at 20°C (including non-linearity and hysteresis)

<0.1% of measuring range \pm 0.7°C

Upscale/downscale drive does not introduce any accuracy errors

Temperature effects on accuracy

{(greater of 0.01% of range or 2 μ V) + 0.01% of reading + 0.03°C} /°C

RTD signals

RTD range

-200 to +850°C (Pt100 type, DIN 43760, IEC751: 1983)

RTD excitation current

100 μ A

Accuracy at 20°C (including non-linearity and hysteresis)

<0.1% of measuring range

Temperature effects on accuracy

{(greater of 0.01% of range or 0.025°C) + 0.005% of reading} /°C



EUROPE (EMEA)
AMERICAS
ASIA PACIFIC
E-mail: enquiry@mtl-inst.com

Tel: +44 (0)1582 723633
Tel: +1 603 926 0090
Tel: +65 487 7887
Web site: www.mtl-inst.com

Fax: +44 (0)1582 422283
Fax: +1 603 926 1899
Fax: +65 487 7997

May 2004

MTL838B-MBF RECEIVERS

BASIC SPECIFICATIONS

(see also 'Common specification')

Number of data highways	MTL838B-MBF
Location of unit	(Modbus® output)
Input noise rejection	2, dual redundant (either or both may be used)
Type of output(s)	Safe area
System protocol	Up to 0.5mA peak-to-peak at 100 to 1000Hz, or up to 1mA peak-to-peak at 50Hz
Serial communication parameters	Dual RS485 Modbus® protocol
	Modbus® ASCII or RTU
	Baud rate: 300 to 19200
	Stop bits: 1 or 2
	Data bits: 7 or 8
	Parity bit: odd, even or none
Multi-receiver facility	Up to 31 MTL838B-MBF units can be connected to communicate with one Modbus® master controller
Power requirement	500mA at 20–35V dc
Ambient temperature limits	-20 to +50°C working
	-40 to +80°C storage
Weight	840g

ADDITIONAL SPECIFICATIONS

MTL838B-MBF

Thermocouple range supported

Types E, J, K, N, R and T THCs to IEC 584. Other options are available, please contact MTL for details.

System configuration

Serial communications parameters and system parameters entered using PCS83 software program, by downloading from process controller. Configuration parameters are retained by using battery-backed RAM.

Linearisation

Multi breakpoint calculation by microprocessor (output is linearised and cold junction compensated)

Broken THC indication

Serial output drives upscale or downscale

Alarm facilities

High and low alarms are indicated in the serial data and can be set for each input



MTL3052

DIGITAL ISOLATOR

for signals up to 10kHz



This unit is similar in principle to the MTL3042 but operates at a higher frequency for use with digital signals. Its primary application is to provide IS protection for the data highways and transmitters in MTL800 Series multiplexer systems. The MTL3052 features two output circuits: one with a 15V 180 safety description, and an alternative 15V 100 circuit which can be used if higher loop resistances need to be accommodated, for example when surge protectors are incorporated in the data highways. If the low-resistance outputs are used on two units fitted to a dual-highway system however, the multiplexer transmitters are restricted to location in IIB atmospheres.

SPECIFICATION

See also 'Common specification'

Number of channels

One, fully floating

Location of load

Zone 0, IIC, T4–6 hazardous area if suitably certified

Div 1, Group A, hazardous location

Zone 0, IIB, T4–6 (Div 1, Group C, hazardous location)

for multiplexer transmitters in dual-highway systems using the low-resistance outputs of two MTL3052s

Input voltage

4 to 12V dc

Signal bandwidth

dc to 10kHz

Minimum output voltage

$[V_{in} \text{ minus } (0.25 \times \text{current in mA})]$ V

Input and output circuit ripple

<1mA peak-to-peak

Power dissipation within unit

160mW maximum at 12V with 20mA signal

Replaceable fuse

50mA, 5 x 20mm glass to DIN 41571 sht. 2, semi-time-lag (M)

'No-fail' earth fault protection (optional)

Enabled by connecting terminal 8 to MTL2220

Fault on either line proclaimed: unit continues working

Safety description

Terminals 5 & 6

15V, 100 , 150mA, $U_m = 250V$ rms or dc

Terminals 6 & 7

15V, 180 , 83.3mA, $U_m = 250V$ rms or dc

FM max entity parameters

$V_{oc} = 15V$, $I_{sc} = 83.3mA$, $C_a = 0.75\mu F$, $L_a = 5.2mH$

Weight

130g

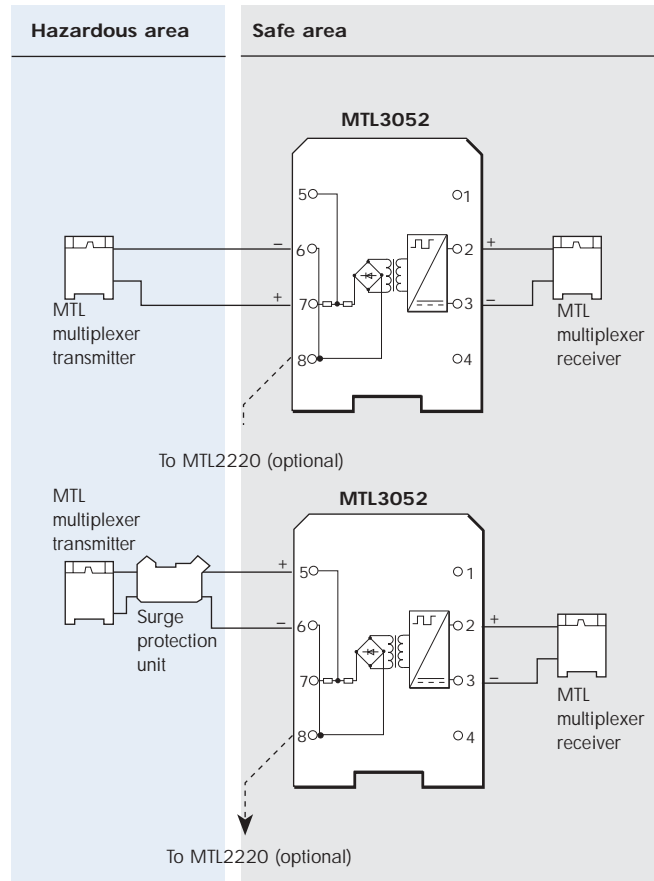

OTHER APPLICATIONS

The MTL3052 is suitable for a variety of other applications, such as bringing back the status of a hazardous-area mechanical or opto-transistor switch, or a magnetic shaft encoder (all via suitable current limiting resistors).



EUROPE (EMEA)
AMERICAS
ASIA PACIFIC
E-mail: enquiry@mtl-inst.com

Tel: +44 (0)1582 723633
Tel: +1 603 926 0090
Tel: +65 487 7887

Fax: +44 (0)1582 422283
Fax: +1 603 926 1899
Fax: +65 487 7997

Web site: www.mtl-inst.com