

# ***TECHNICAL TRAINING***



## ***HA41PX-NT – HA130JRT-NT And TN122 models***

## How to use this document?

**MAINTENANCE AND REPAIR OPERATIONS ON YOUR HAULOTTE MACHINE  
MUST BE DONE ONLY BY TRAINED ,EXPERIENCED AND AUTHORIZED TECHNICIANS**

*You have between the hands the summary given during the HAULOTTE . technical training .  
It will enable you to find information necessary for the maintenance and the repair of  
your HAULOTTE .machine*

*Thanks to the guide below you will reach the required chapter quickly.*

### **Chapter 1: Main features and functions**

It is a resume of the information contained in the manual user delivered with the machine:  
components, overall dimensions, working zones, commands, etc...

### **Chapter 2: Study of the electric schematics**

You will find there the elements as following:

- A summary of the standardized symbols used by HAULOTTE Group
- The complete wiring diagram of the studied model
- The non exhaustive list of the electric looms and electronic boards
- Localization of the main safety units (tilt , limit switches, sensors,transducers...)
- Logical equations of operation: by function, to diagnose the main dysfunctions

### **Chapter 3: Study of the hydraulic schematics**

You will find there the elements as following:

- a summary of the standardized symbols used by HAULOTTE Group
- the complete hydraulic diagram of the studied model
- the non exhaustive list of the hoses track
- the localization of the principal hydraulics manifold (proportional block , on/off movements block,...)

### **Chapter 4: Adjustments**

This is the adjustments and calibrations, hydraulics and electric, necessary to the good maintenance of the material. You will find as well the methods of adjustment with table values.

### **Chapter 5: Guide of breakdown**

Quick summary of the step to be followed for possible sources of breakdown.

In case of any defect or any dysfunction you will be able to identify the elements in question, whatever they are electric or hydraulic.

### **Chapter 6: Summary of the versions**

This manual treats of the latest version , however this summary table enables you to find the former versions of the material (electric and hydraulics).

### **Chapter 7: Special functions**

This chapter gathers all the functions and adjustment specific to carry out on the machine.

There does not exist for all the materials and depends on the studied model.

It must be the subject of a special attention of your share because an intervention badly carried out can deteriorate the good performance of the machine and thus consequently the safety of the users.

Only a technician HAULOTTE or approved by HAULOTTE Services is able to carry out this kind of intervention.

On this chapter, some special adjustment (sensors) are also explained prior to calibration

### **Chapter 8 : machine modified called kit TN122**

This model is a hybrid between the HA41PX 1<sup>st</sup> version and the NT version

The main modifications are the new outreach limitation procedure with new sensors and link part compensation automatic process.( same as for NT version)

### **Chapter 9 : Lists of schematics**

This chapter lists all schematics (electric/hydraulic) of the different versions



## REVISION

Revision	Edition	Subject	Created by	Validated by	Modified by	Translated by	Language
00	12-08	Creation HA41PX Std (cancelled)	MGD	FLC		External company	FR/EN/D/IT
00	03-11	Creation NT version	MGD	FLC		MGD	FR/EN
01	03-12	Add TN122 modification + updated schematics	MGD	FLC		MGD	FR/EN/SP
02	07-13	Add newest schematics with new power line 246 on sensors	MGD	FLC		MGD	FR/EN
03	12-13	Add Diag Pad info + console alarm list	MGD	Central R&D	MGD	MGD	FR/EN
04	02-14	Add chapter schematics			MGD		FR/EN
05	07 - 14	Add newest option like ASB (Active Shield Bar) Add list of parameters console for HA41PX-TN122			MGD		EN
06	04-15	Add coloured schematics in A3 format	MGD	PUS-MM			EN
07	07- 18	Add new failures code compatible with Haulotte Diag (see chapter 4.2)	MGD		MGD		EN
08	06-19	Add screen shots for calibration using Haulotte diag V3	ERUIZ		MGD		EN
09	12 - 21	Redesigned coloured schematics + ASB	MGD		MGD		EN

## SUMMARY

<b>1. MAIN FEATURES .....</b>	<b>7</b>
1.1. CHARACTERISTICS .....	7
1.1.1. <i>main components</i> .....	7
1.1.2. <i>Overall dimensions</i> .....	8
1.1.3. <i>working zone</i> .....	9
1.1.4. <i>Features</i> .....	10
1.2. THE CONTROLS (UP AND DOWN) .....	11
<b>2. THE ELECTRICAL PART .....</b>	<b>15</b>
2.1. COLOR IDENTIFICATION ON RESISTANCES .....	15
2.2. SCHEMATICS .....	16
2.3. THE MAIN PRINTED CIRCUIT (LOW CONTROL BOX) .....	16
2.4. THE MODULE NODE B1 (UPPER CONTROL BOX) .....	16
2.5. THE MAIN SAFETY COMPONENTS .....	17
2.5.1. <i>Sensors location</i> .....	17
2.6. LIST OF COMPONENTS .....	28
2.6.1. <i>engine</i> .....	28
2.6.2. <i>Fuses</i> .....	29
2.6.3. <i>inputs module node A (lower controls)</i> .....	30
2.6.4. <i>inputs module node b1 (upper controls)</i> .....	31
2.6.5. <i>Outputs</i> .....	34
2.7. LOGICAL EQUATIONS OF OPERATION .....	37
2.7.1. <i>engine</i> .....	37
2.7.2. <i>drive</i> .....	38
2.7.3. <i>Steering</i> .....	39
2.7.4. <i>Boom lift</i> .....	40
2.7.5. <i>Arm lift</i> .....	41
2.7.6. <i>Telescoping boom</i> .....	43
2.7.7. <i>Telescoping arm</i> .....	44
2.7.8. <i>Turret slewing</i> .....	45
2.7.9. <i>arm/link part compensation</i> .....	46
2.7.10. <i>Releasing oscillating axle</i> .....	46
2.7.11. <i>jib</i> .....	47
2.7.12. <i>Compensation</i> .....	48
2.7.13. <i>basket rotation</i> .....	49
2.7.14. <i>Extension axles and blocking</i> .....	49
<b>3. THE HYDRAULIC PART .....</b>	<b>50</b>
3.1. THE HYDRAULIC SCHEMATICS .....	50
3.2. VALVES LOCATION .....	50
3.3. HYDRAULIC PUMPS .....	51
3.3.1. <i>drive pump</i> .....	51
3.3.2. <i>equipment pump</i> .....	51
3.4. CYLINDERS (TURRET) .....	52
3.5. MAIN MANIFOLD .....	53
3.5.1. <i>Hydraulic block in chassis (front part)</i> .....	53
3.5.2. <i>Hydraulic block (rear chassis)</i> .....	57
3.5.3. <i>turret blocks</i> .....	58
3.6. HELP GUIDE FOR HYDRAULIC LEAKS .....	62

<b>4.</b>	<b>ADJUSTMENTS.....</b>	<b>98</b>
4.1.	ADJUSTMENTS WITH OPTIMIZER CONSOLE.....	98
4.1.1.	<i>Codes alarms</i> .....	104
4.1.2.	<i>main menu</i> .....	108
4.1.3.	<i>Parameter settings</i> .....	116
4.2.	HAULOTTE DIAG CONSOLE.....	117
4.3.	ADJUSTMENT OF THE PRESSURES.....	120
4.3.1.	<i>Table of pressures</i> .....	120
4.3.2.	<i>pressure port</i> .....	121
4.3.3.	<i>equipment pump</i> .....	121
4.3.4.	<i>drive pump</i> .....	122
<b>5.</b>	<b>BREAKDOWN SERVICE GUIDE.....</b>	<b>123</b>
5.1.	NO START.....	123
5.2.	NO MOVEMENT.....	123
5.3.	NO DRIVE.....	124
5.4.	NO HIGH SPEED.....	124
5.5.	NO LOW SPEED.....	124
5.6.	NO STEERING ON FRONT AXLE.....	124
5.7.	NO STEERING ON REAR AXLE.....	124
5.8.	NO EXTENSION OF THE AXLES.....	125
5.9.	NO OSCILLATING LOCK.....	125
5.10.	NO ARM LIFTING.....	125
5.11.	NO ARM TELESCOPING.....	125
5.12.	NO LINK PART COMPENSATION.....	126
5.13.	NO BOOM LIFT.....	126
5.14.	NO TELESCOPING BOOM.....	126
5.15.	NO TURRET SLEWING.....	126
5.16.	NO JIB.....	127
5.17.	NO ROTATION BASKET.....	127
5.18.	NO BASKET COMPENSATION.....	127
<b>6.</b>	<b>SUMMARY OF VERSIONS HA41PX.....</b>	<b>127</b>
<b>7.</b>	<b>SPECIAL FUNCTIONS.....</b>	<b>128</b>
7.1.	MOVEMENTS WITH AXLES RETRACTED.....	128
7.2.	CONDITIONS FOR AXLES EXTENSION.....	128
7.3.	CONDITIONS FOR TELESCOPING ARM EXTENSION.....	129
7.4.	CONDITIONS FOR ARM DESCENT.....	130
7.5.	LINK PART COMPENSATION.....	131
7.5.1.	<i>Functional description</i> .....	131
7.5.2.	<i>case of shifting</i> .....	131
7.6.	LOAD MANAGEMENT SYSTEM.....	132
7.6.1.	<i>Operation</i> .....	132
7.6.2.	<i>Principle of the load control</i> .....	132
7.6.3.	<i>Angle sensors</i> .....	132
7.6.4.	<i>Procedure of overload calibration</i> .....	133
7.6.5.	<i>values of the overload sensors</i> .....	135
7.7.	SYSTEM OF REACH LIMITATION (HA41PXNT).....	136
7.7.1.	<i>Principle</i> .....	136
7.7.2.	<i>Calibration</i> .....	137
7.7.3.	<i>Normal indicative values of the sensors</i> .....	144
7.8.	SENSORS ADJUSTMENT.....	145
7.8.1.	<i>Angle transducers</i> .....	145
7.8.2.	<i>Length transducers</i> .....	145
7.8.3.	<i>magnetic sensors (ils type) and magnet position</i> .....	146
7.8.4.	<i>How to understand the sensors reading in points</i> .....	147

**8. CALIBRATION PROCESS WITH HAULOTTE DIAG.....148**

8.1. LOAD.....148

8.2. REACH LIMIT .....151

**9. MACHINES EQUIPPED WITH KIT TN122 .....159**

9.1. EXPLANATION .....159

9.2. SPECIFIC DATAS .....160

9.3. LIST OF PARAMETERS.....161

9.4. CALIBRATION PROCESS .....172

    9.4.1. *load system* .....172

    9.4.2. *outreach system* .....172

**10. LIST OF SCHEMATICS.....180**

10.1. HYDRAULIC FUNCTION .....181

10.2. ELECTRICAL FUNCTION .....198



# 1. MAIN FEATURES

## 1.1. CHARACTERISTICS

### 1.1.1. MAIN COMPONENTS

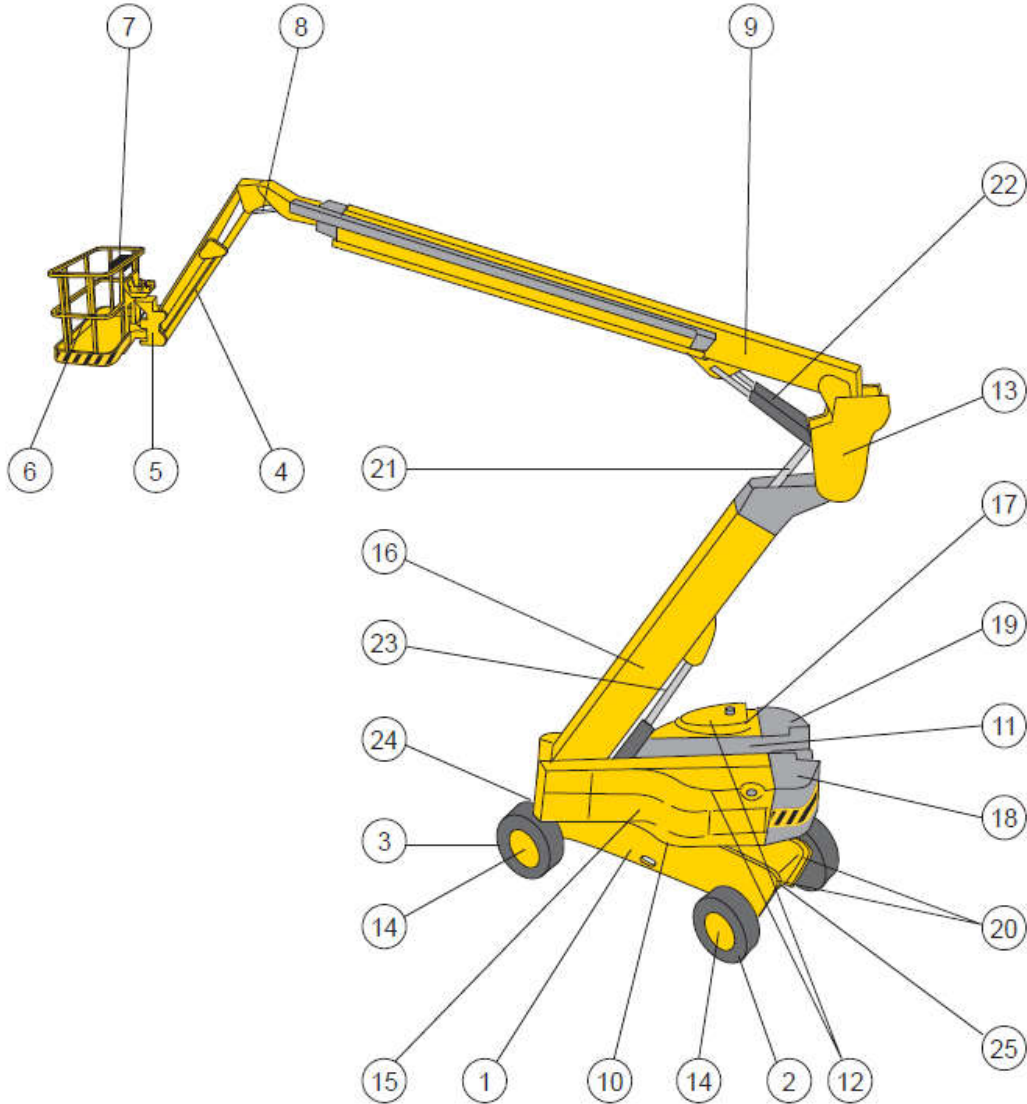

1 - Rolling frame	13 - Part of connection arm/beam
2 - Driving wheels and forward steering	14 - Hydraulic motors for transfers + reduction gear
3 - Driving wheels and rear steering	15 - Right Compartment (hydraulic reservoirs and diesel, control panel)
4 - Suspension platform	16 - Arm 3 elements
5 - Rotary Jack	17 - Left Compartment (driving + pump + starter battery)
6 - Platform	18 - Right Counterweight
7 - Control panel platform	19 - Left Counterweight
8 - Compensation jack	20 - Anchor points
9 - 3 fly jib elements	21 - Compensation jack linkage component
10 - Steering crown	22 - Fly jib lifting jack
11 - Turret	23 - Arm lifting jack
12 - Caps	24 - Fixed extensible Axle
	25 - Turning extensible Axle

**1.1.2. OVERALL DIMENSIONS**

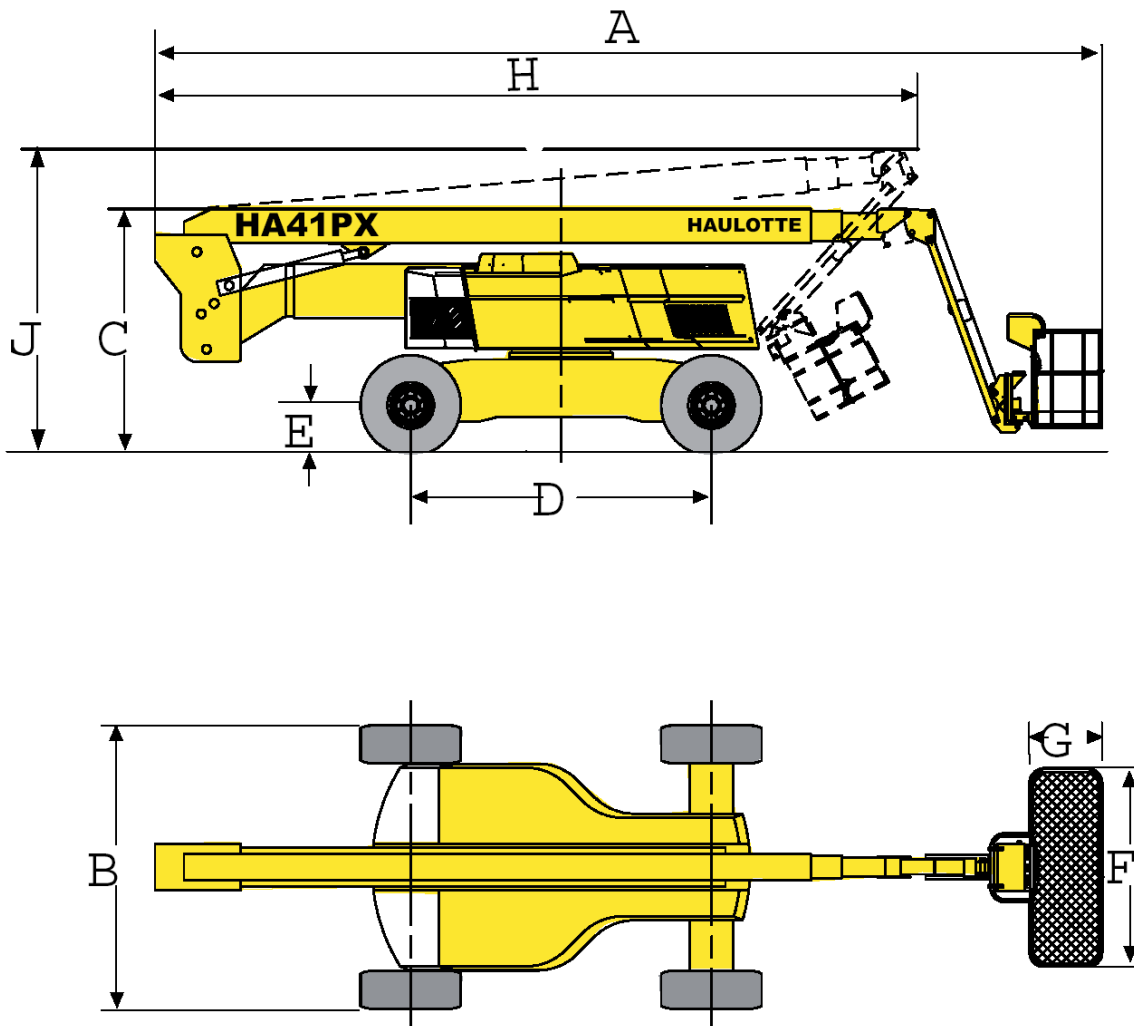

	HA41PX	
A	12,6 m	41 ft 4 in
B	2,53 m	8 ft 3 in
C	2,99 m	9 ft 9 in
D	3,5 m	11 ft 48 in
E	0,294 m	0,96 ft
F X G	2,44 m X 0,8 m	8 ft X 2 ft 62 in
H		
J	3,7 m	12 ft 1 in

**1.1.3. WORKING ZONE**

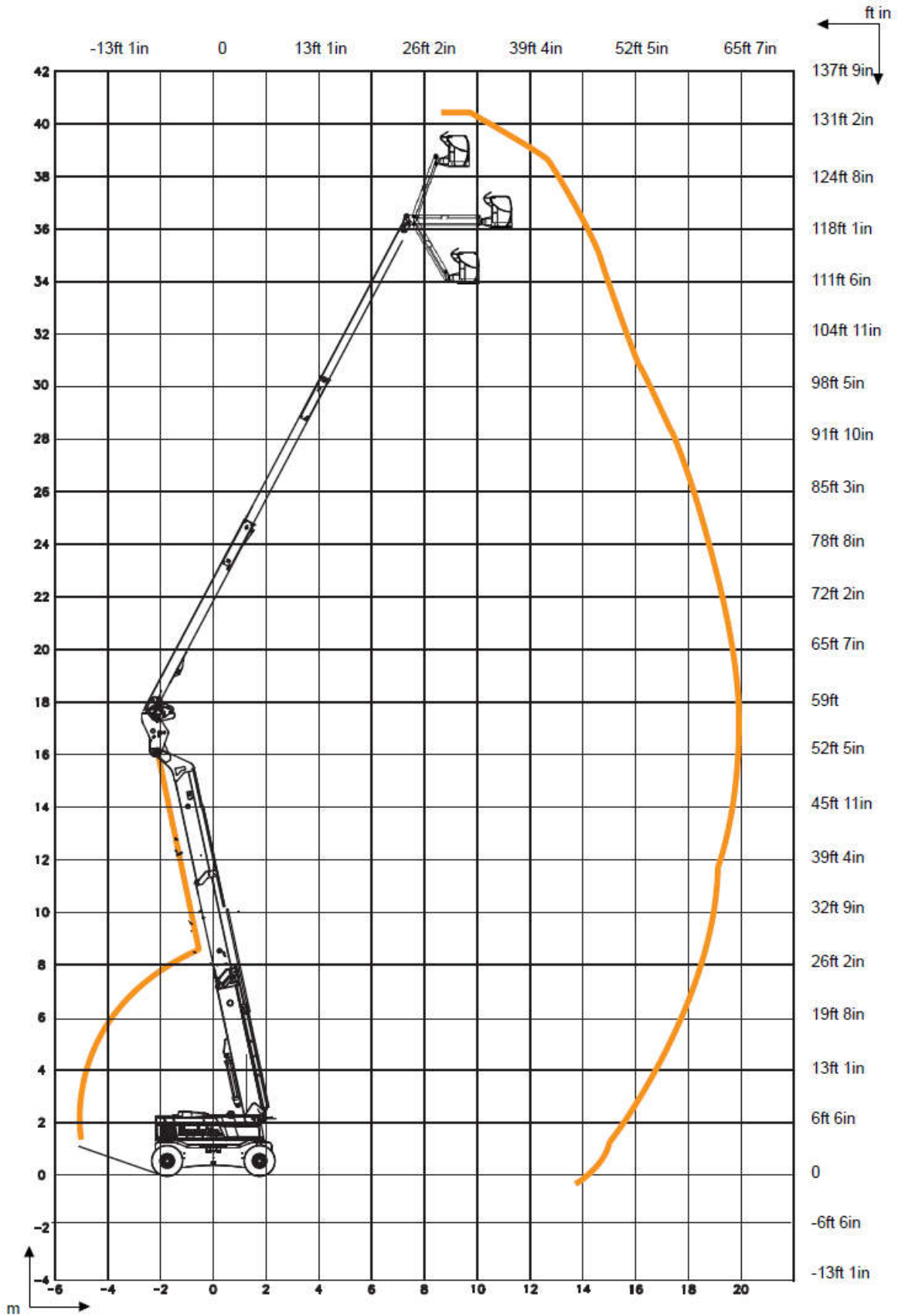

### 1.1.4. FEATURES

Machine Characteristics	HA41PX-NT		HA130JRT-NT	
	Metric	Imperial	Metric	Imperial
Length of machine in stowed position	12,60 m	(41 ft 4 in)	12,60 m	(41 ft 4 in)
Width of the machine in stowed position	2,53 m	(8 ft 3 in)	2,53 m	(8 ft 3 in)
Machine height	2,99 m	(9 ft 9 in)	2,99 m	(9 ft 9 in)
Maximum ground clearance	0,38 m	(1 ft 3 in)	0,38 m	(1 ft 3 in)
Transport height	3,70 m	(12 ft 1 in)	3,70 m	(12 ft 1 in)
Transport length	12,30 m	(40 ft 4 in)	12,30 m	(40 ft 4 in)
Maximum work height	40,40 m	(132 ft 7 in)	40,40 m	(132 ft 7 in)
Maximum platform height	38,50 m	(126 ft 0 in)	38,50 m	(126 ft 0 in)
Maximum drift	19,80 m	(64 ft 11 in)	19,80 m	(64 ft 11 in)
Maximum radius	19,30 m	(63 ft 3 in)	19,30 m	(63 ft 3 in)
Turntable rotation	360 °			
Boom rotation angle	+70° / -40° s			
Jib working range	+65° / -65° s			
Platform length	0,80 m	(2 ft 7 in)	0,80 m	(2 ft 7 in)
Platform width	2,44 m	(8 ft 0 in)	2,44 m	(8 ft 0 in)
Platform rotation angle	+87° / -87° s			
Outer turning radius (without retracted axle adjustment)	5,10 m	(16 ft 8 in)	5,10 m	(16 ft 8 in)
Inner turning radius (with axles retracted)	2,70 m	(8 ft 10 in)	2,70 m	(8 ft 10 in)
Distance between centres of the wheels	3,50 m	(11 ft 5 in)	3,50 m	(11 ft 5 in)
Machine width, with axles extended	3,30 m	(10 ft 9 in)	3,30 m	(10 ft 9 in)
TiltCE - AS	2 °			
Rated slopeANSI - CSA	0 °			
Slope warningANSI - CSA	5 °			
Maximum wind speed allowed	45 km/h	(28 mph)	45 km/h	(28 mph)
Front axle load	16530 kg	(36442 lb)	16530 kg	(36442 lb)
Rear axle load	6570 kg	(14484 lb)	6570 kg	(14484 lb)
Total weight	23000 kg	(50715 lb)	23000 kg	(50715 lb)
Maximum platform load	230 kg	(507 lb)	230 kg	(507 lb)
Maximum number of persons on the platform	2			
Engine type	Diesel - Perkins 1104D-44 Turbo			
Engine power	62 kW	(84 Hp)	62 kW	(84 Hp)
Engine power when idle	43 kW	(57,6 Hp)	43 kW	(57,6 Hp)
Fuel consumption when idle	220 g/kWh			
Sound level at 10 m (32 ft 9 in)	< 74 dB (A)			
Sound power	108 dB (A)			
Hand vibration	<2,5 m/s <sup>2</sup>	(98,4 in/s <sup>2</sup> )	<2,5 m/s <sup>2</sup>	(98,4 in/s <sup>2</sup> )
Feet vibration	<0,5 m/s <sup>2</sup>	(19,6 in/s <sup>2</sup> )	<0,5 m/s <sup>2</sup>	(19,6 in/s <sup>2</sup> )
Fuel tank capacity	140 l	(37 gal US)	140 l	(37 gal US)
Hydraulic tank capacity	240 l	(63 gal US)	240 l	(63 gal US)
Starter battery	12 V-135 Ah			
Differential lock	Yes			
Maximum climbable slope	40 %			
Type of tyres	Foam-filled-445/65D22,5			
Wheel nut torque	57 daN.m	(420 lbf.ft)	57 daN.m	(420 lbf.ft)
Slew ring torque	21,5 daN.m	(158 lbf.ft)	21,5 daN.m	(158 lbf.ft)
Maximum pressure on hard ground	12,5 daN/cm <sup>2</sup>	2,56 lbf/sq.ft	12,5 daN/cm <sup>2</sup>	2,56 lbf/sq.ft
Maximum pressure on soft ground	6,1 daN/cm <sup>2</sup>	1,25 lbf/sq.ft	6,1 daN/cm <sup>2</sup>	1,25 lbf/sq.ft
Micro drive speed	0,5 km/h	(0,3 mph)	0,5 km/h	(0,3 mph)
High drive speed	5 km/h	(3,1 mph)	5 km/h	(3,1 mph)
Manual lateral effort	CE - AS : 400 N - 90 lbf		ANSI - CSA : 666 N / 150 lbf	



**1.2. THE CONTROLS (UP AND DOWN)**

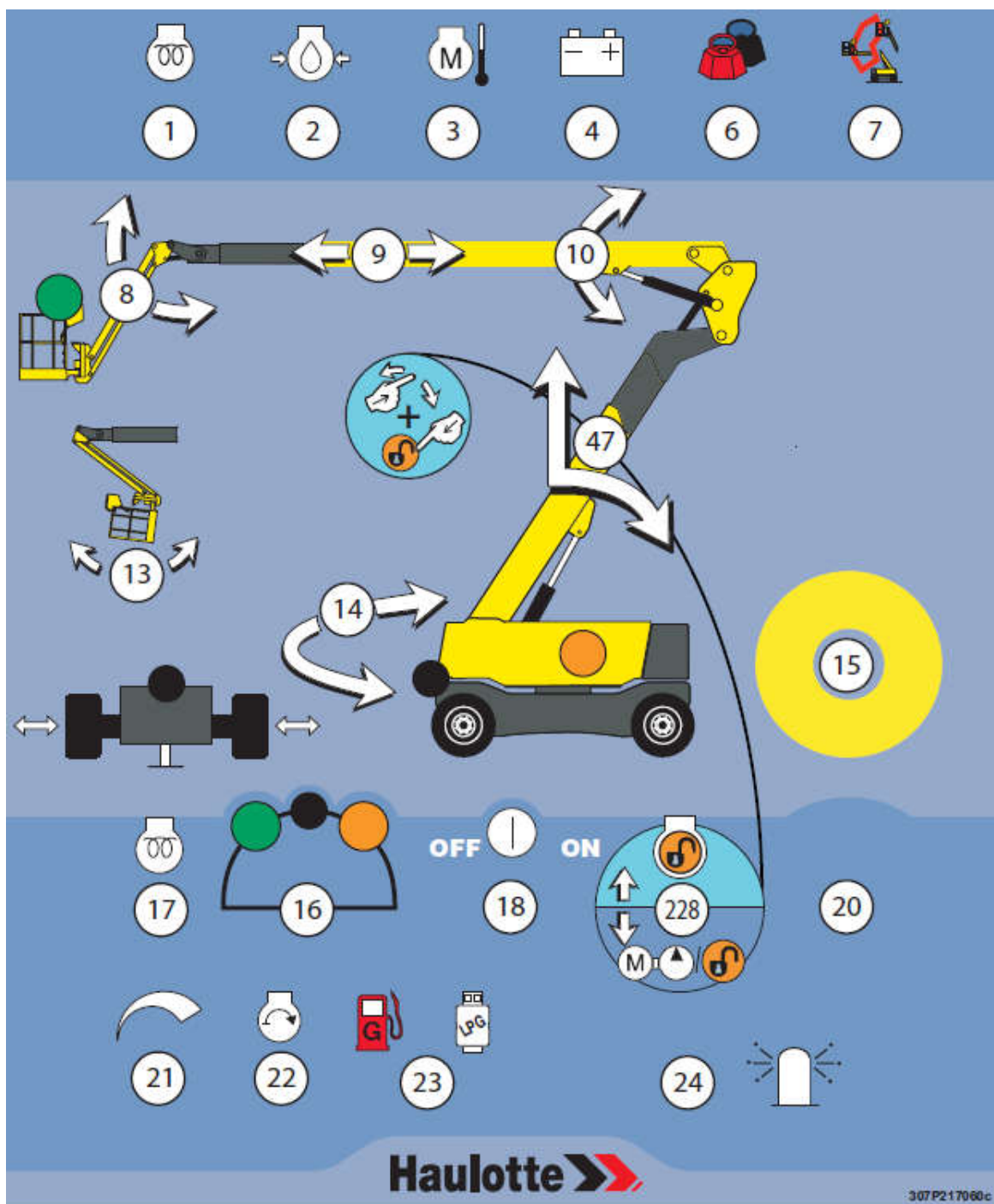



Marking	Description	Function
1	Electric pre-heating indicator	On : Engine in pre-heating mode Off : Engine pre-heated, starting possible
2	Engine oil pressure indicator	Low engine oil pressure <sup>1</sup>
3	Engine temperature indicator	High engine oil temperature <sup>1</sup>
4	Battery charge indicator	Low battery charge <sup>1</sup>
6	Platform overload indicator	Platform overload indicator
7	Radius limitation indicator	Close to radius limitation : • The indicator flashes • Movement is slowed down Radius limitation reached : • The indicator flashes continuously • An automatic movement is performed to return to the authorized radius limitation
8	Jib lifting / lowering selector button	Moved upwards : Jib lifting Moved downwards : Jib lowering
9	Boom telescoping selector	Move to the left : Telescope extension Move to the right : Telescope retraction
10	Boom raising selector	Moved upwards : Boom raising Moved downwards : Boom lowering
13	Platform compensation or transport position selector	Move to the right : Platform compensation lowered or placed in transport position Move to the left : Platform compensation lifted or placed in operating position
14	Turntable rotation selector	Move to the left : Counter clockwise (CCW) rotation Move to the right : Clockwise rotation
15	Emergency stop button	Pulled out (activated) : Ground control box switched on Pushed down (deactivated) : De-energizes control system
16	Control box activation keyed selector switch	Left : Platform control box activated Center : Axle control box activated Right : Ground control box activated
17	Engine pre-heating selector	Moved downwards : Engine pre-heating
18	ON/OFF selector	ON : Energizes control system OFF : De-energizes control system
20	Hour meter	Total machine running hours
21	Engine acceleration selector	Move to the right : Engine speed acceleration Move to the left : Engine speed when idle
22	Engine start-up selector	Engine start-up and shutdown
23	Petrol/Gas selector <sup>2</sup>	LPG : Gas supply G : Petrol supply
24	Beacon light selector	Move to the right : Beacon light activated Move to the left : Beacon light deactivation
47	Arm telescoping or lifting selector	Moved upwards : Telescope extension or arm lifting Moved downwards : Telescope retraction or arm lowering
228	'Dead man' selector / Back-up unit selector <sup>3</sup>	Moved upwards : Movement validation Moved downwards : Back-up unit activated Movement validation

1. Perform the required maintenance (see the machine maintenance book)
2. For equipped machines
3. For equipped machines



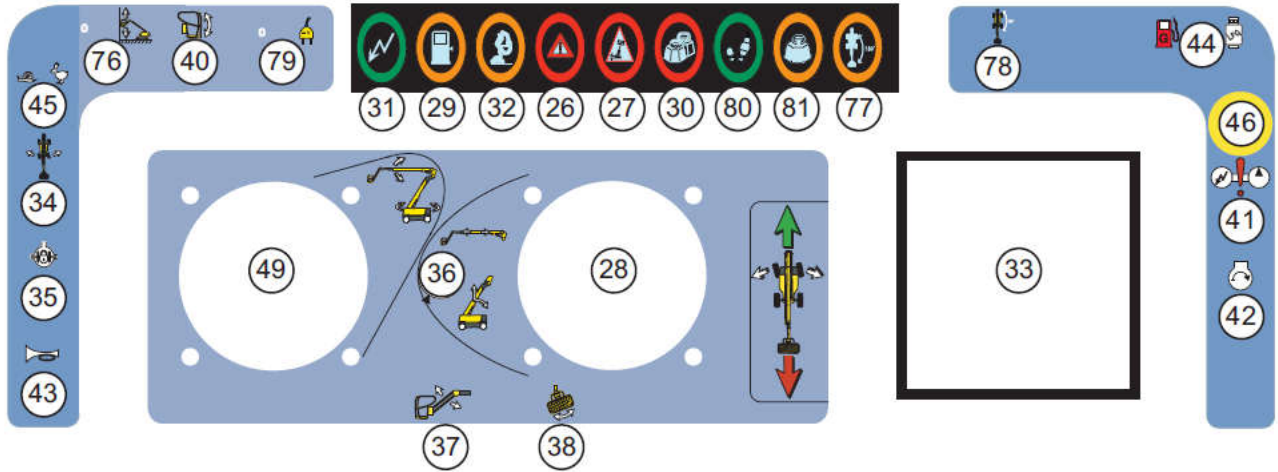



## 2. THE ELECTRICAL PART

### 2.1. COLOR IDENTIFICATION ON RESISTANCES

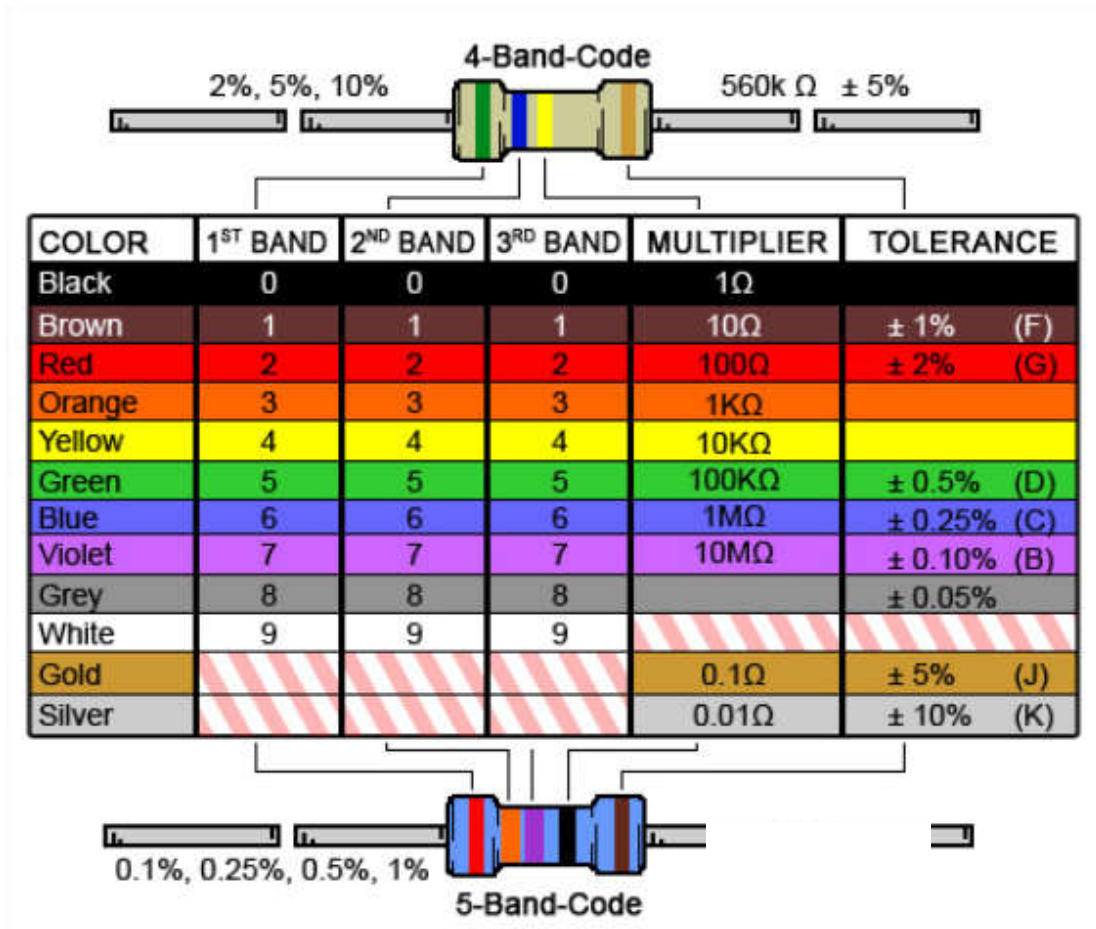

## 2.2. SCHEMATICS

see all versions at the end of this manual  
For more details on harnesses/loom, refer to parts book

## 2.3. THE MAIN PRINTED CIRCUIT (LOW CONTROL BOX)

See at the end of this manual

## 2.4. THE MODULE NODE B1 (UPPER CONTROL BOX)

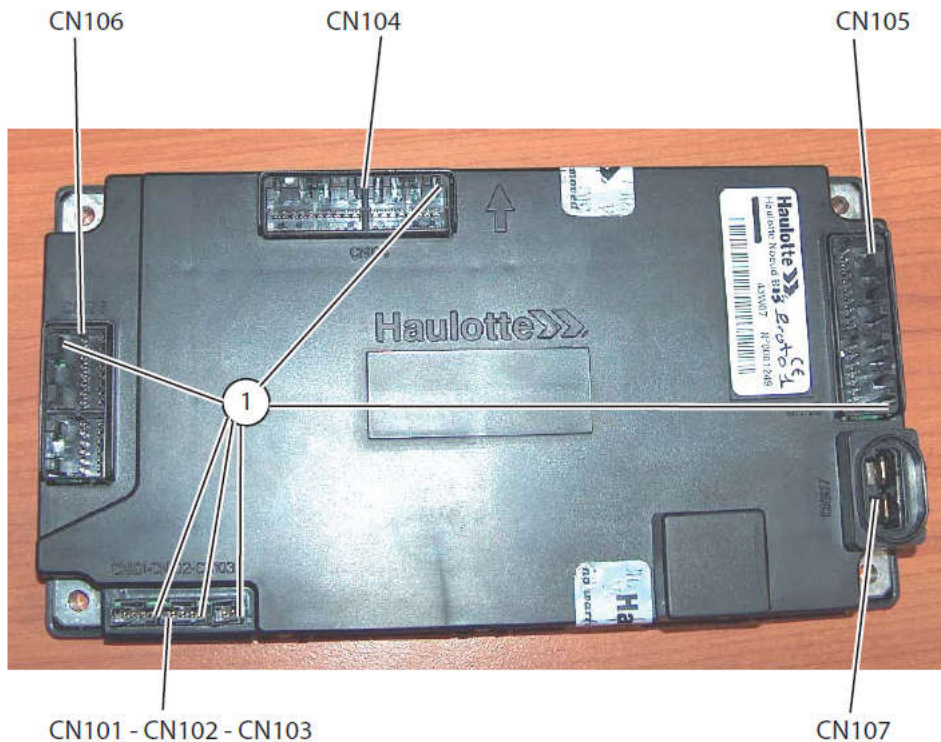

Détail du brochage côté calculateur

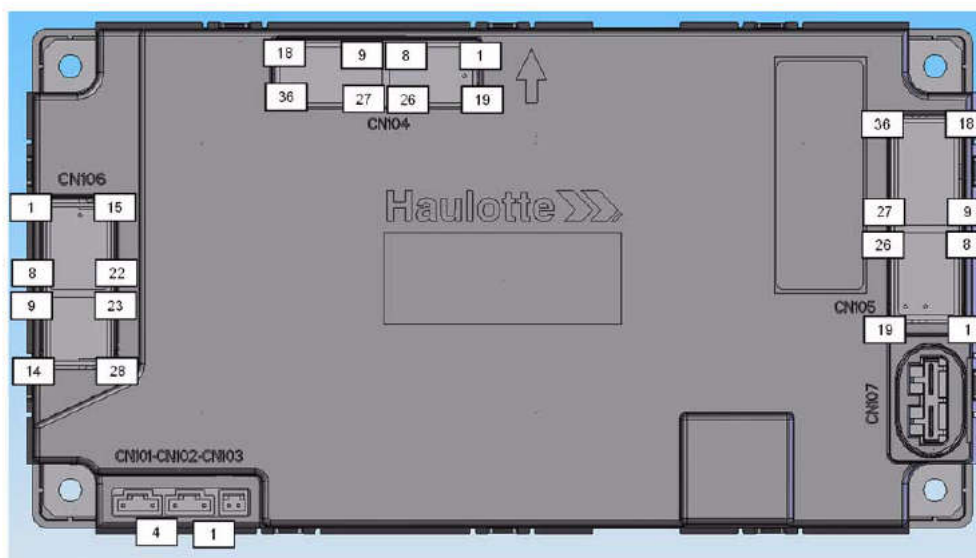

## 2.5. THE MAIN SAFETY COMPONENTS

### 2.5.1. SENSORS LOCATION

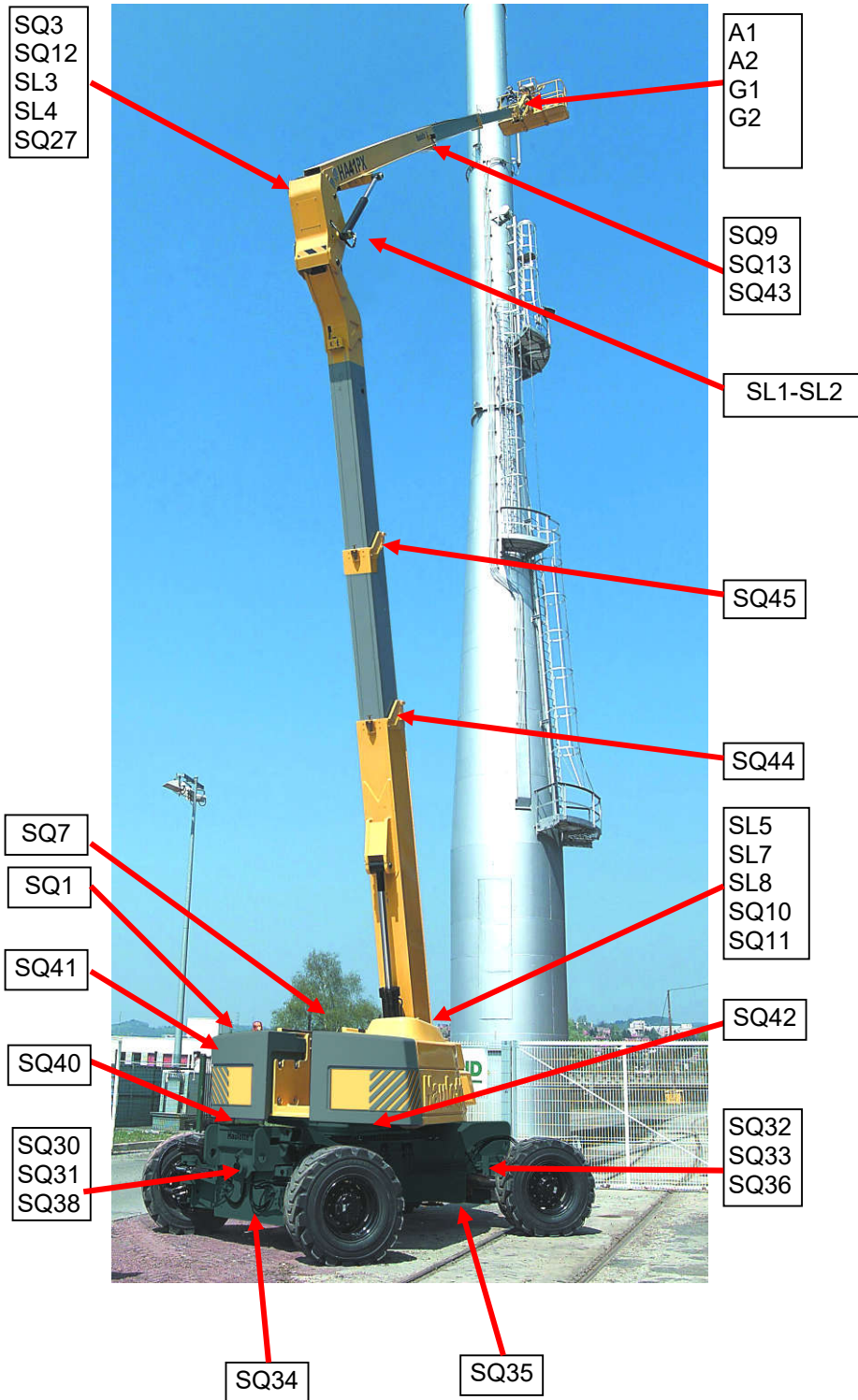

Designation	Element	Function
SQ1	Tilt sensor 4°	Cut all the movements (=0 if in slope)
SQ3L	Low detection boom angle	(= 1 if > 0°)
SQ3H	High detection boom angle	(=1 if < 50°)
SQ7	Detection arm up	(=1 if arm > 75.5°)
SQ9	Telescopic boom retracted	(= 1 if telescope retracted)
SQ10	Telescopic arm retracted	(= 1 if telescope retracted)
SQ11	Boom on turret	(= 1 if boom on turret)
SQ12	Chain broken on rear boom section	Cut-off engine (= 0 if broken)
SQ13	chain broken on front boom section	Cut-off engine (= 0 if broken)
SQ27	Detection angle link piece arm /boom	(=1 if link part in front of magnet)
SQ30	Left front axle extended	Cut-off movements except turret and boom lift /drive speed possible if in intermediate position (= 0)
SQ31	Right front axle extended	Cut-off movements except turret and boom lift /drive speed possible if in intermediate position (= 0)
SQ32	Detection right rear axle	Cut-off movements except turret and boom lift /drive Speed possible if in intermediate position (= 0)
SQ33	Left detection rear axle	Cut-off movements except turret and boom lift /drive speed possible if in intermediate position (= 0)
SQ34	Outrigger fully retracted	Cut all the movements/drive except turret rotation and boom lift (= 1 if outrigger retracted)
SQ35	Outrigger fully retracted	Cut all the movements/drive except turret rotation and boom lift (= 1 if outrigger retracted)
SQ36	ILS detection rear axle	(= 1 if retracted or extended, 0 in intermediate position: drive is possible)
SQ38	ILS detection front axle	(= 1 if retracted or extended, 0 in intermediate position; drive is possible)
SQ40	Turret centered on chasis	Cut the oscillating axle movement (=1 if centered)
SQ41	Reserve fuel	Switch for Reed purpose (= 1 low fuel in tank)
SQ42	ILS Detection turret centered on chasis	Cut the oscillating axle movement (=1 if centered or at 180°)
SQ43	ILS Detection zones telescope boom	Limit the range (=1 if in front of magnet)
SQ44	Detection ILS zones telescope arm (was 1)	Limit the range (=1 if in front of magnet)
SQ45	Detection ILS zones telescope arm (was 2)	Limit the range (=1 if in front of magnet)
SL1/SL2	Measure angle boom by magnetostrictive sensor integrated in the left cylinder of the boom	Limit the range (4-20mA)
SL3/SL4	Measure length boom	Limit the range (0-12V)
SL5	Measure angle arm	Limit the range (4-20mA)
SL7/SL8	Measure length arm	Limit the range (0-12V)
A1	jib relative angle	Manage the overload (0 -12V)
A2	jib absolute angle	Manage the overload (0.-12V)
G1	Pressure small chamber jib cylinder	Manage the overload (0 - 5V)
G2	Pressure large chamber jib cylinder	Manage the overload (0 - 5V)



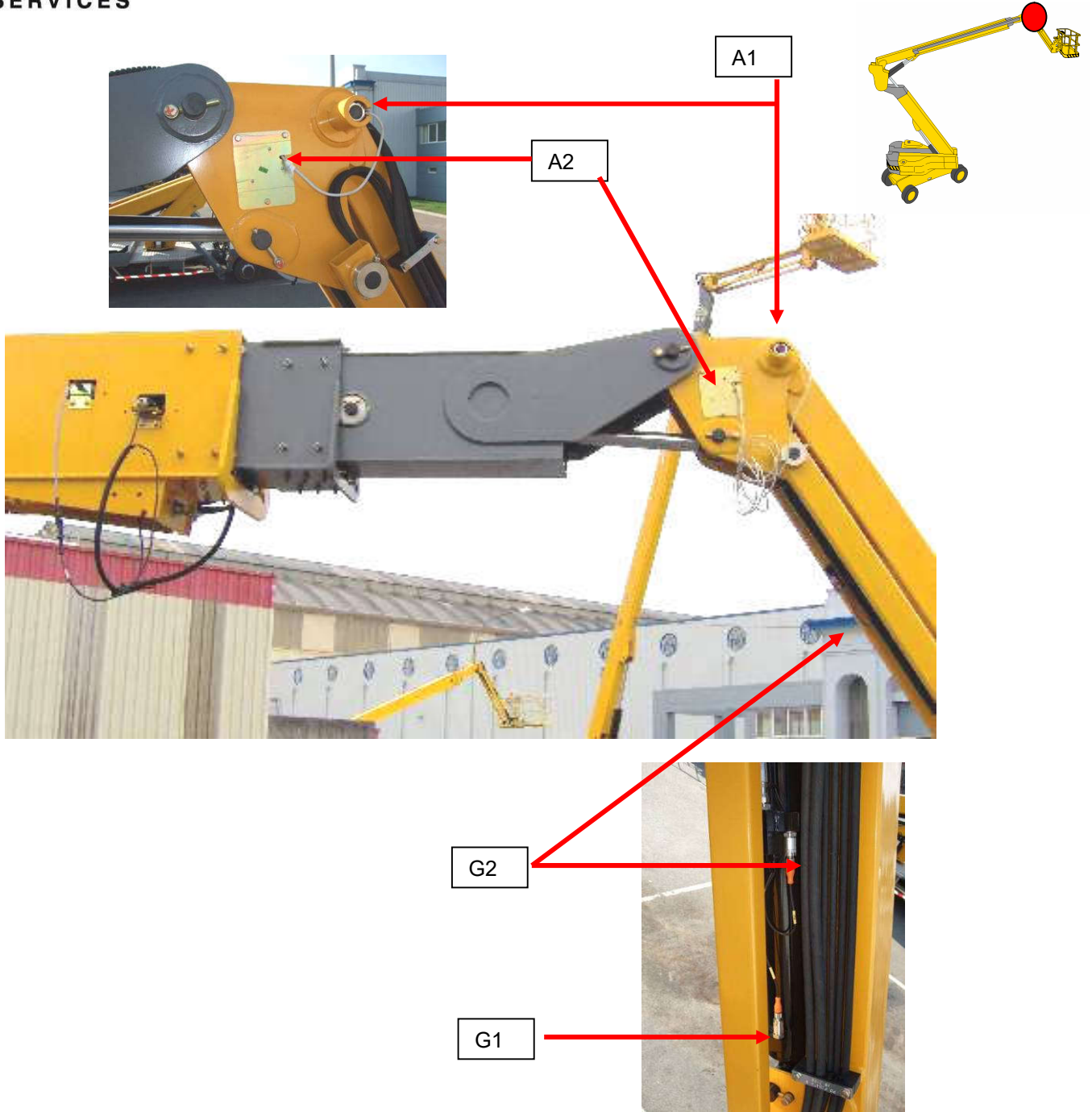

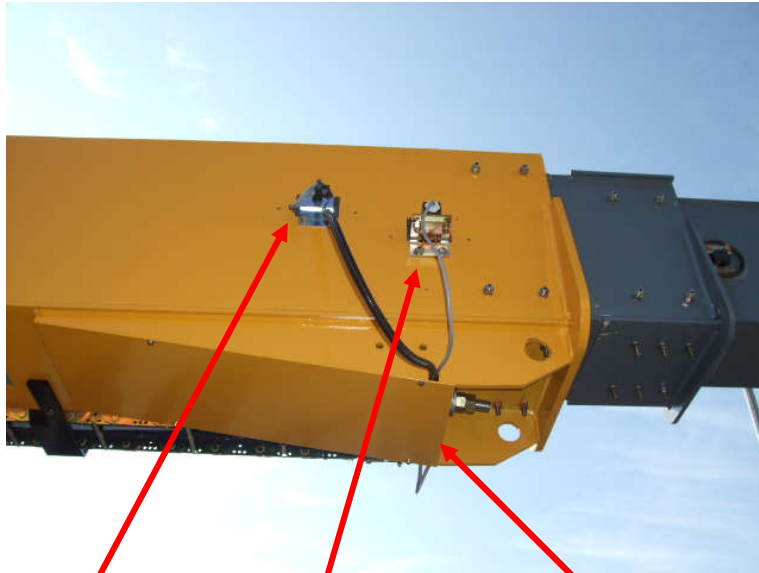
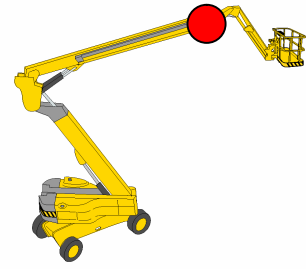

SQ43

SQ9

SQ13

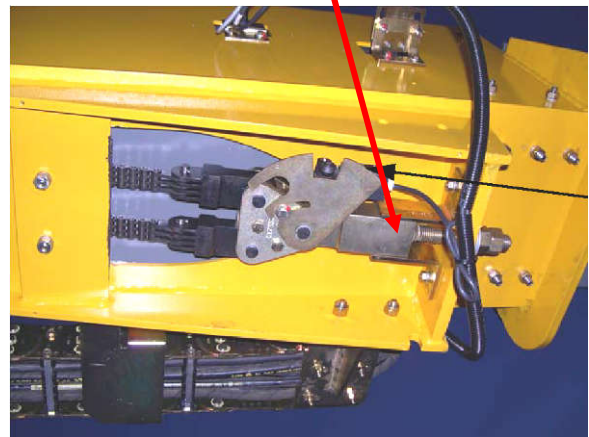
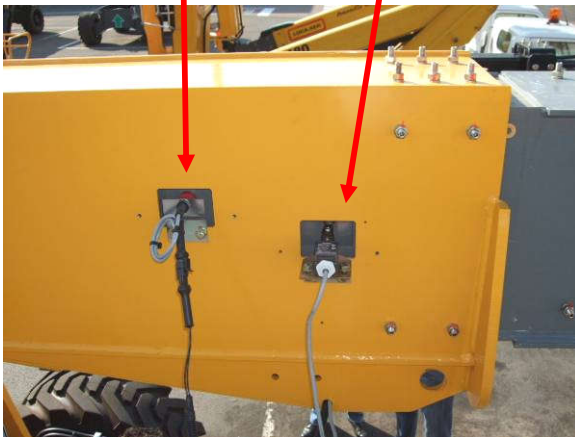

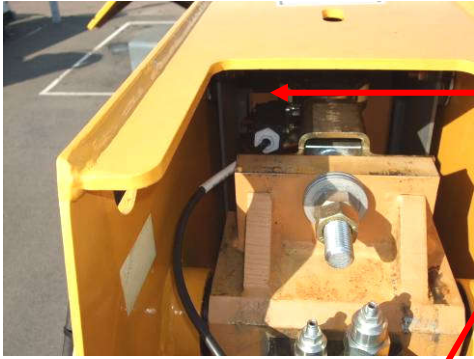
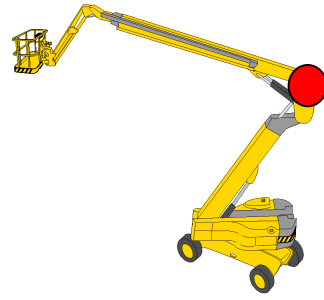

SQ12

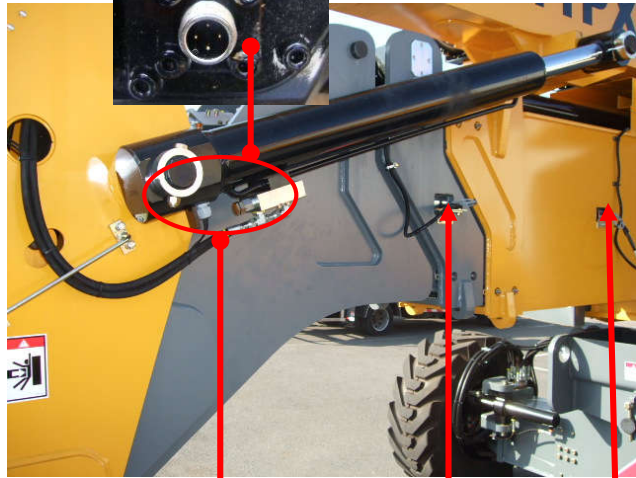

SL1-SL2

SQ45

SQ44

SL3-SL4



SQ3L-SQ3H

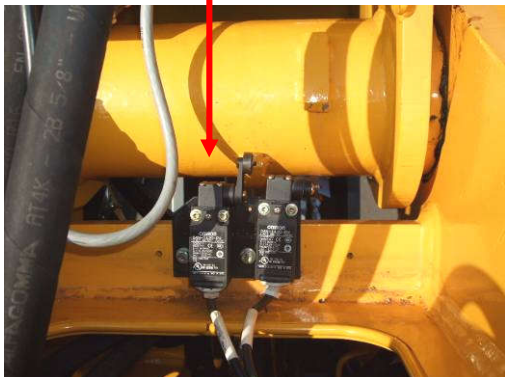



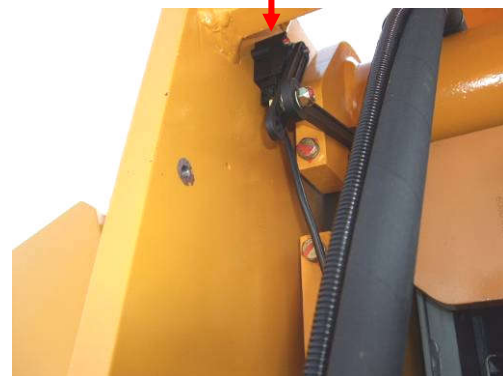
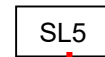
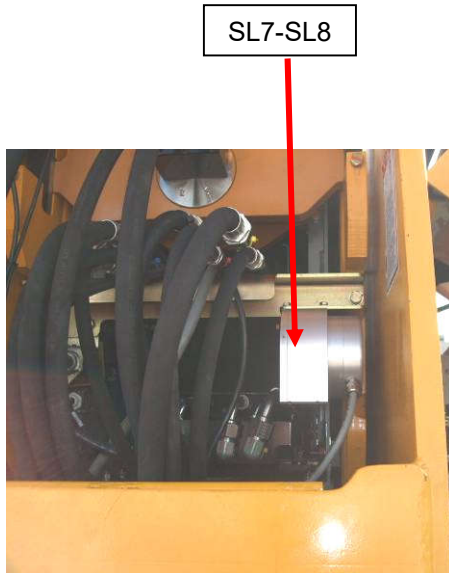
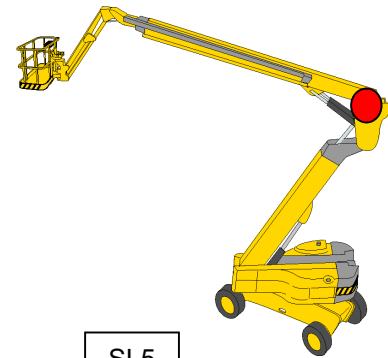
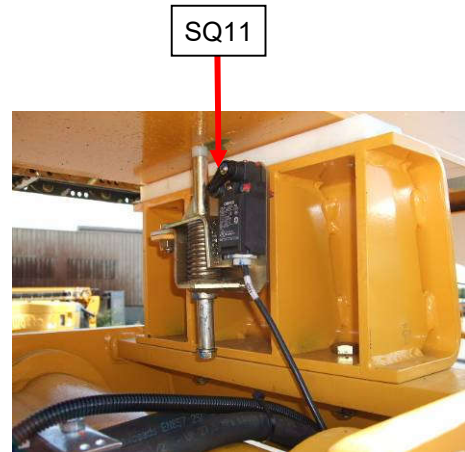
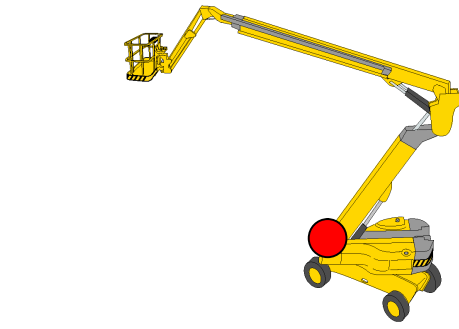
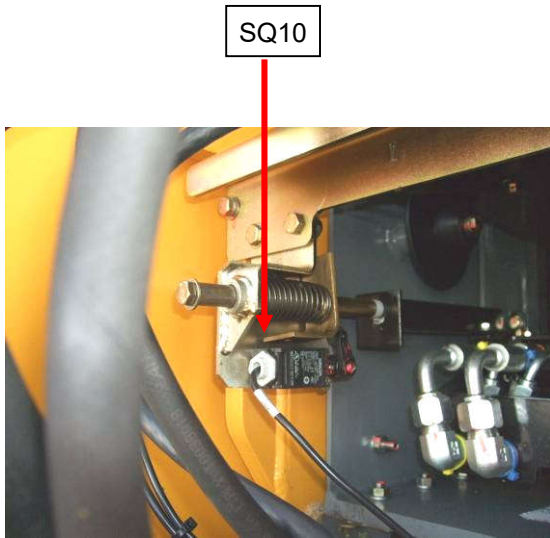



SQ30

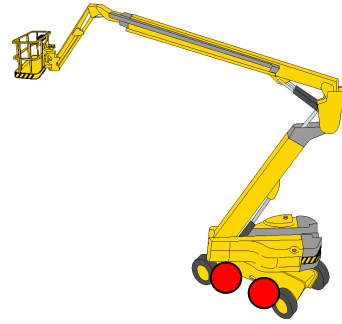

SQ31

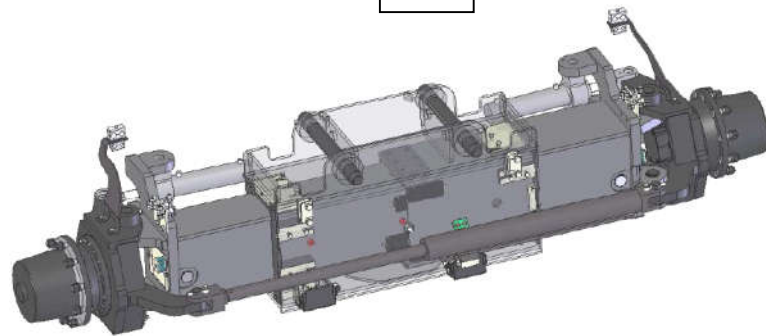
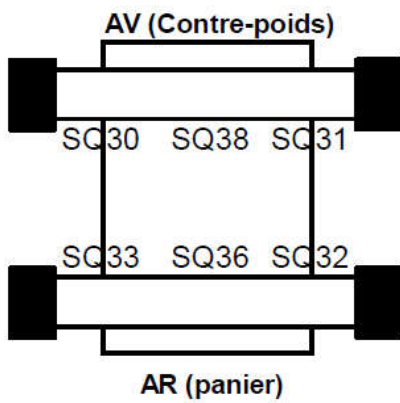

SQ32

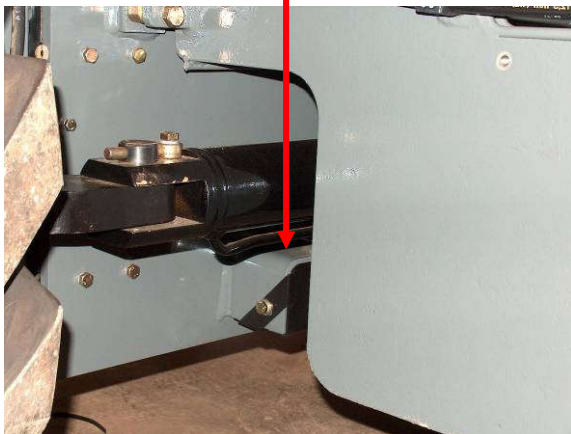

SQ33

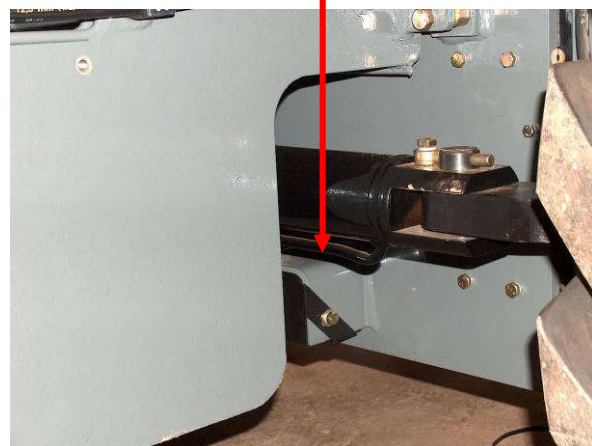

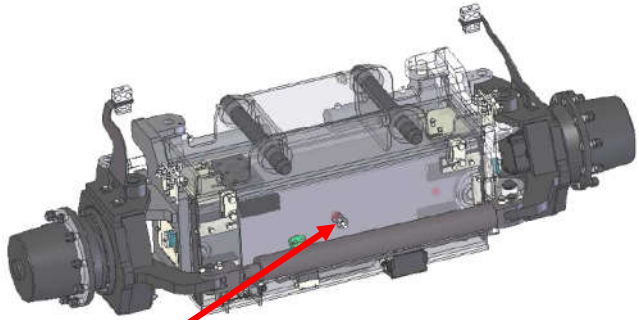
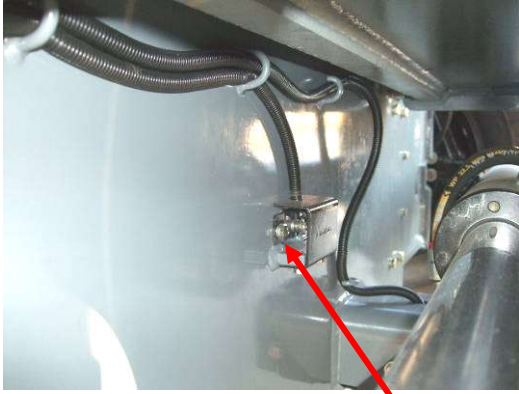

Front axle: SQ38  
Rear axle: SQ36

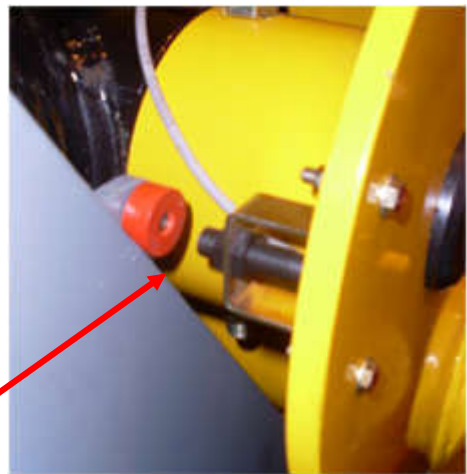
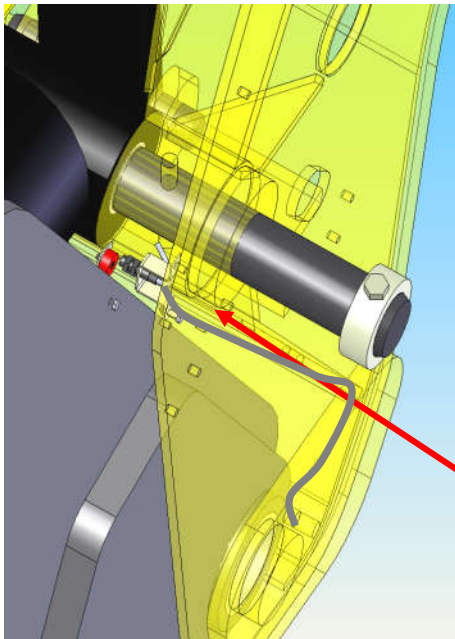
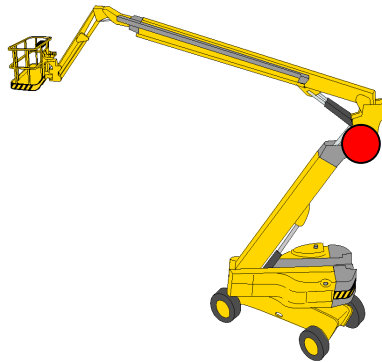

SQ27



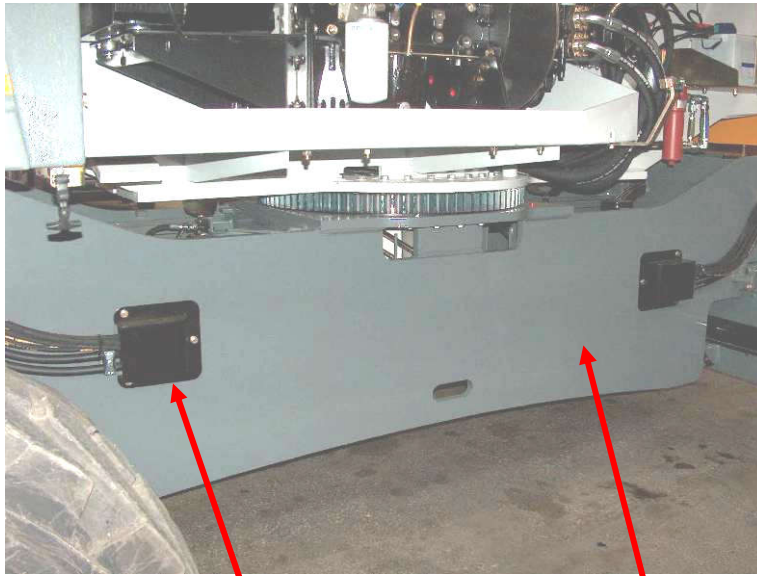
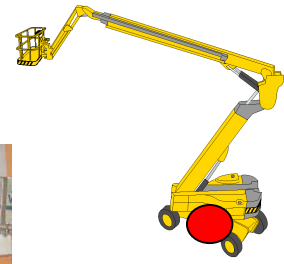

SQ34

SQ35

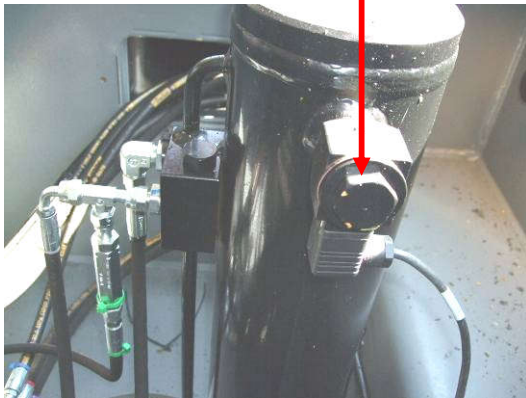

SQ41



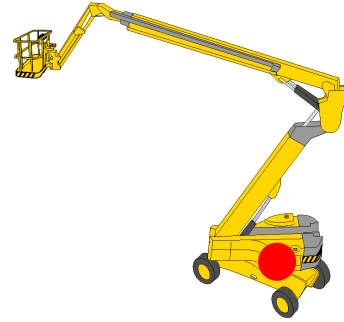
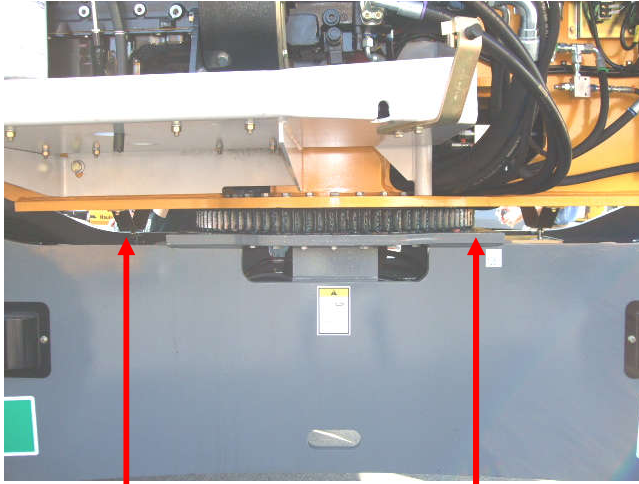

SQ40

SQ42

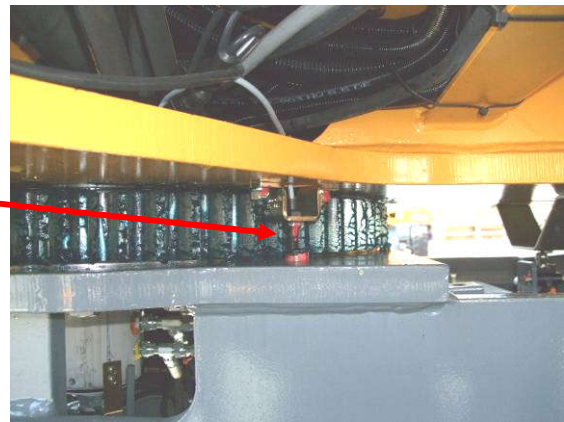

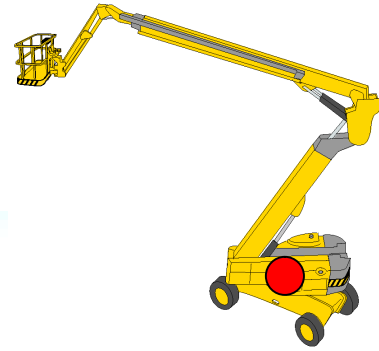

SQ1

B4

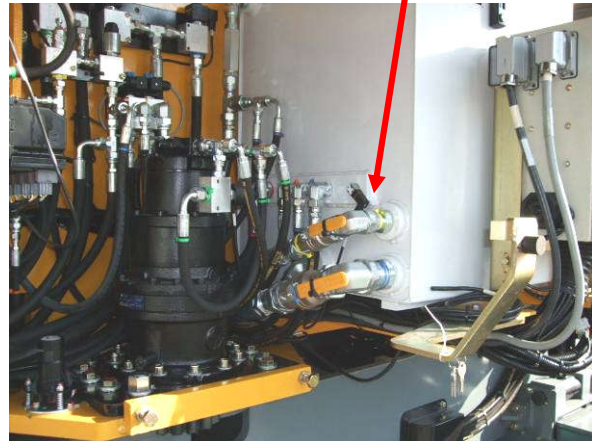

## 2.6. LIST OF COMPONENTS

In the following tables:

The column n°2 gives the coordinates of the components on different the sheets from the wiring schematics in order to find their position easily.

The first figure corresponds to the number of page and the second to the column (generally from 1 to 20) of the corresponding page

The column n°3 indicates the position on the connector of the printed circuit or the module if it is necessary

The wiring schematics is cut in 4 parts (motor, turret, basket, frame),

The location of the connector could thus sometimes be similar for two completely different components because it will refer to distinct diagrams.

For all these conditions, the fuses will have to be checked as a preliminary

The possible options specific to certain countries are not indexed (for more information, it is appropriate to refer to the wiring diagram corresponding to your machine

The numbered wires Bxxx are connected to the module Node B of the upper control box.

By defect the other wires are connected to the module Node A of the lower control box.

The state noted "0" corresponds to 0V, opened contact or not activated.

The state noted "1" corresponds to the tension of the circuit, closed or activated contact.

- **Glossary**

FWD	Forward (drive)
REV	Reverse (drive)
FL	Front Left
FR	Front Right
RL	Rear Left
RR	Rear Right
PF	Platform
LS	Low Speed drive
LS valve/adj	Load sensing valve/adjustment
MS	Medium Speed drive
HS	High Speed drive
ILS	Magnet sensor (Interrupteur Lame Souple)

### 2.6.1. ENGINE

ENGINE ELEMENTS			
M3	01 - 5		Starter (101)
M4	01 - 2		Emergency pump (142)
G 2	01 - 7		Alternator (101)
YA1	01 - 14		diesel supply valve coil (116)
YA2	01 - 11		Accelerator (909)
YA3	01 - 12		diesel injection valve coil (116)
YA4	01 - 13		Surcaleur (116) (reduced white smoke during cold engine start)
EV	01 - 20		Option cooler for hydraulic oil (161)
D+	04 - 13 2	27.1	Alternator (109 = Vbat if alternator powered)

## 2.6.2. FUSES

FUSES			
FU 1	01 - 13		Supply diesel injection valves coil 10A (115)
FU 3	01 - 8		Preheating 80A (119)
FU 4	01 - 5		Starter 30A (120)
FU 5	03 - 9		lower control box commands 3A (212)
FU 6	03 - 7		upper control box commands 3A (211)
FU 8	03 - 13		+ 12 V permanent 5A (242)
FU 9	03 - 18		Supply accessories 20A (905)
FU 10	03 - 16		Electrovalve YV1 Load Sensing 3A (302)
FU 11	01 - 20		Option cooler 11A (160)
FU 13	01 - 3		Emergency pump 250A (100)
FU 14	01 - 11		Accelerator 10A (166)
FU 16	03 - 4		Supply 12V module node B 7.5A (246)
FU 70	03 - 14		Protection valves 20A (201) if an valve is supplied permanently: FU70 is destroyed <u>(fuse is on door and replaces the FU7 located inside the main printed circuit board in turret)</u>
FU 120	03 - 15		For magnetostrictive sensor SL1-SL2 1A (242-1A)



### 2.6.3. INPUTS MODULE NODE A (LOWER CONTROLS)

INPUTS			
SA0	03 - 2		Main power (241)
SA1	03 - 2		Selection of commands (low /upper box)
SA2	04 - 9	28.7	Accelerator (605)
SA6	04 - 7	28.15	Jib (lower control box) SA6a lift (920)
		28.13	SA6b descent (919)
SA8	04 - 2	4.15	Telescopic boom (lower control box) SA8a retraction (411)
		4.14	SA8b extension (412)
SA13	04 - 3	28.2	Boom lift (lower control box) SA13a descent (505)
		28.1	SA13b lift (504)
SA14	04 - 4	28.6	Arm Lift (lower control box) SA14a descent (511)
		28.3	SA14b lift (510)
SA15	04 - 5	28.9	Orientation (lower control box) SA15a Right (517)
		28.4	SA15b Left (516)
SA16	03 - 11		Option beacon (906)
SA19	04 - 12	28.14	Emergency Pump (lower control box) (915)
		29.3	Enable switch turret movements (611A)
SA21	04 - 8	50.4	Basket compensation lower control box: SA21b lift (256)
		50.3	SA21a descent (255)
SB0	02 - 3		Emergency stop chassis (121)
SB1	03 - 2		Emergency stop (102)
SB3	04 - 10	4.12	Start/stop engine (117a)
SB7	04 - 11	4.6	Preheating (406)

## 2.6.4. INPUTS MODULE NODE B1 (UPPER CONTROLS)

INPUTS			
SWB2	06 - 3		Emergency stop (215)
SB6	06 - 19	105.12	Foot pedal (B141)
SWB02	06 - 11	104.11	Option generator (B116)
SWB03	06 - 14	104.9	Basket compensation A1 lift (B114)
		104.10	A2 descent (B115)
SWB05	06 - 9	104.6	Selection speed of drive (B111)
SWB06	06 - 17	105.10	Steering rear axle A1 right (B104)
		105.11	A3 left (B105)
SWB07	06 - 10	104.2	Differential lock (B107)
SWB08	06 - 7	29.5	Horn (B106)
SWB11	06 - 15	104.15	jib A1 lift (B120)
		104.16	A3 Descent (B121)
SWB12	01 - 8	105.1	Selection movements arm /boom (B122)
SWB13	06 - 12	104.17	Basket rotation A1 right (B123)
		104.18	A3 left (B124)
SWB16	06 - 5	105.3	Start/stop engine (B128)
SWB17	06 - 6	105.4	Emergency pump (B129)

JYB01	07 - 8	104.3 104.4 105.7 105.6 106.10	Drive joystick right steering (B108) left steering (B109) off neutral REV (B101) Off neutral FWD (B100) Y signal (B300) FWD from 2.5 to 0.5 V REV from 2.5 to 4.5 V
JYB02	07 - 5	105.8 106.11	Telescopic joystick: off neutral (B102) Y signal movement (B301) extension from 2.5 to 0.5 V Retraction from 2.5 to 4.5 V
JYB03	07 - 3	30.12 29.15 30.10	orientation and lifting (arm and boom) joystick off neutral (B103) X signal orientation (B303) Signal from 4.5 with 0.5V Y signal lifting (B302) lift from 2.5 to 0.5 V Descent from 2.5 to 4.5V

MODULES			
			Head module node A
			module node B1

SAFETY SENSORS			
SQ1	05 - 3	16.1	Tilt sensor (205 = 0 if in slope)
SQ3L	05 - 15	41.2	Low detection boom angle (207 = 0 from -40° to 0°)
SQ3H	05 - 14	51.2	High detection boom angle (257= 1 from - 40°to +50°)
SQ7	05 - 5	45.2	Detection position arm (204 = 1 if angle > 75.5°)
SQ9	05 - 17	37.2	Telescopic boom extension (218A =1 if retracted)
SQ10	05 - 8	38.2	Telescopic arm extension (222 =1 if retracted)
SQ11	05 - 4	16.1	Boom low position (485 = 1 if aligned on turret)
SQ12	05 - 18	36.2	chain broken boom bottom (218b = 0 if broken)

SQ13	05 - 19	47.2	Chain broken boom head (251 = 0 if broken)
SQ27	05 - 13	29.6	ILS magnet detection link piece (705 =1 if on magnet)
SQ30	02 - 13	CE20/30.1	Detection front left axle extension (213 = 1 if OUT)
SQ31	02 - 12	CE21/30.14	Detection front right axle extension (611C=1if OUT)
SQ32	02 - 14	CE26/30.4	Detection rear right axle extension (311 = 1 if OUT)
SQ33	02 - 15	CE25/30.5	Detection rear left axle extension (401 = 1 if OUT)
SQ34	02 - 7	CE19/30.12	Detection front stabilizer (420A =1 if IN)
SQ35	02 - 8	CE22/30.13	Detection rear stabilizer (420B = 1 if IN)
SQ36	02 - 10	CE17/30.3	ILS magnet detection rear axle (310 =1 if In or OUT and = 0 in intermediate position)
SQ38	02 - 9	CE18/30.6	ILS magnet detection front axle (402 =1 if IN or OUT and = 0 in intermediate position)
SQ40	02 - 11	CE24/30.2	Turret alignment (214 = 1 if centered)
SQ41	05 - 3	48.2	low fuel detection (252 = 1 if on reserve)
SQ42	05 - 4	46.2	ILS magnet is the redundancy for turret alignment (250 = 1 if on magnet)
SQ43	05 - 17	43.2	ILS magnet measures the length on telescopic boom (115A = 1 if in front of magnet)
SQ44	05 - 9	44.2	ILS magnet measures the length on telescopic boom (115B = 1 if in front of magnet)
SQ45	05 - 10	42.2	ILS magnet measures the length on telescopic arm (232 = 1 if in front of magnet)
SL1/SL2	05 - 16	30.10/30.11	Magnetostrictive sensor boom angle (418/419)
SL3/SL4	07 - 19	106.1/106.2	Sensors boom length (B308/B309)
SL5	05 - 7	29.15	Sensor arm angle (611B)
SL7/SL8	05 - 11	51.4/29.12	Sensors arm length (259/901)
A 1	07 - 13	106.15	Relative angle sensor for weighing (B304)
A 2	07 - 12	106.16	Angle sensor for weighing (inclinometer) (B305)
G 1	07 - 16	106.24	Pressure sensor small chamber jib cylinder (B306)
G 2	07 - 18	106.25	pressure sensor large chamber jib cylinder (B307)
B2	01 - 16		Pressure switch engine oil overheating (111 = 1 if T high) )
B3	01 - 15		Pressure switch oil engine (112 = 0 if P < 0.5 bars)
B4	05 - 1	40.2	Temperature hydraulic oil (904 = 0 if T >80°C)
B7	01 - 20		Overheat hydraulic oil (option cooler) (161)
B8	02 - 6	CE23/30.8	Detection high speed drive (409 = 0 if P > 14b)



## 2.6.5. OUTPUTS

RELAYS			
KA1	03 - 14	52.2	horn (260)
KA2	04 - 14		starter (146)
KA37	04 - 15		accelerator (922A)
KP1	04 - 13		Engine stop coil (150)
KM4	04 - 18	49.2	emergency pump (253)
KM5	04 - 17	12.3	preheating (305)
KM24	04 - 19	32.2	option generator (911)
KMG1	03 - 2		Cut-off main power (241-2)
KMG2	03 - 5		Cut-off sensors line only after 2 secs after main power is switched off (698)

VALVES			
YV1	05 - 20	20.2	Load Sensing (303)
YV2	05 - 18	29.9/53.2	YV2a extension axles, stabilizers, steering (804) YV2b, jib, compensation, basket rotation (804)
YV3	05 - 13	22.3/34.2	Lifting arm + link part of compensation (403A) Raise: from 50 to 75% of battery voltage Descent: from 50 to 25% of battery voltage
YV4	05 - 15	23.3/10.2	Boom lift (506A) Raise: from 50 to 75% of battery voltage Descent: from 50 to 25% of battery voltage
YV5	05 - 16	29.11/11.2	Turret slewing (807) from 50 to 75% of battery voltage
YV6	05 - 12	24.3/35.2	Telescoping arm (512A) extension: from 50 to 75% of battery voltage Retraction from 50 to 25% of battery voltage
YV7	05 - 10	25.3/13.2	Telescoping boom (612A)
YV8	02 - 13	CE11/15.8	Authorization for stabilizers/chassis movement (307)
YV9	02 - 11	CE10/15.4	Differential lock (807A)

YV10	02 - 15	CE12/15.9	High speed drive (807B)
YV12	02 - 16	CE13/8.11	braking release (813)
YV15A	07 - 3	105.28	Descent basket compensation (B600)
YV15B	07 - 4	105.27	Raise basket compensation (B607)
YV18A	07 - 5	105.32	jib descent (B604)
YV18B	07 - 6	105.31	jib raise (B603)
YV19A	07 - 7	105.34	Basket rotation right (B606)
YV19B	07 - 8	105.33	Basket rotation left (B605)
YV21A	02 - 6	CE8/8.10	Front right steering (818)
YV21B	02 - 7	CE9/8.9	Front left steering (814B)
YV22A	02 - 8	CE6/15.3	Rear right steering (304)
YV22B	02 - 9	CE7/15.6	Rear left steering (306)
YV30A	05 - 1	31.2	Forward drive (414a)
YV30B	05 - 2	54.2	Reverse drive (263)
YV31	02 - 14	CE11/15.7	wheels lock during axle extension (307)
YV33	02 - 12	CE14/8.1	Releasing oscillating axle (601)
YV27	05 - 2	8.12	Link part /arm compensation (814A)
YV34	05 - 3	21.2	Safety turret slewing (417A)
YV35	05 - 4	19.2	Telescopic arm extension1 (402A)
YV36	05 - 5	17.2	Telescopic arm extension 2 (407A)
YV38	05 - 5	18.2	Safety arm lift (401A)
YV40	05 - 6	8.3	link part compensation (921A)
YV41	05 - 7	8.6	telescopic boom safety extension (814C)
YV42	05 - 8	8.3	Safety boom descent (309)

LIGHTS AND BUZZER			
HA1	03 - 17		Buzzer (905)
HA4	04 - 3 4	14.2	Buzzer lower control box (210A)
HL1	04 - 5		Light operation alternator (109)
HL3	04 - 9	4.2	Overheat oil engine (111A)
HL4	04 - 8	4.1	Oil pressure engine (112A)
HL5	01 - 9		Light preheating (104)
HL6	07 - 11		Work headlight Option (905)
HL11	03.-11		Option beacon (906)
HL16	04 - 7	56.2	Overload indication in lower control box (398)
HL17	04 - 6	28.15	Indication of reach limitation lower control box (914)
HL20	04.-10	33.2	Option flashing lights (304A)
BZB01	06 - 19	104.29	Buzzer defects (B508)
LTB01	06 - 12	104.21	Indication dead man's pedals (B500)
LTB02	06 - 12	104.22	Indication power (B501)
LTB03	06 - 13	104.23	Indication fuel reserve (B502)
LTB04	06 - 14	104.24	Indication danger (B503)
LTB05	06 - 15	104.25	Indication slope (B504)
LTB06	06 - 15	104.26	Indication overload (B505)
LTB07	06 -16	104.27	Indication reach limitation (B506)
LTB08	06 - 17	104.28	Free (B507)
LTB09	06 - 18	104.30	Free (B509)

## 2.7. LOGICAL EQUATIONS OF OPERATION

For all these conditions, the fuses will have to be checked first  
 The condition of the equations of operation described below refers to the standard EN280, machines known as Standard (for other standards USA, CDN, AUS) thank you to refer to HAULOTTE SERVICES of your sector which will indicate the characteristics of your machine  
 All fuses have been checked

### 2.7.1. ENGINE

Function	Action	CONDITIONS		
		Necessary	Prohibiting the function	Modifying the function
Start	KA2=1	SB0 = 0 + SA0 = 1 + SA1 (side I or II) + SB3=1 (or SWB16=1 and D+= 1	Engine already started	
			Movement in progress	
			Starting battery defective	
			SQ12 or SQ13=0	

Function	Action	CONDITIONS		
		Necessary	Prohibiting the function	Modifying the function
Engine supply	YA 1=1 + YA3= 1 + YA4 = 1	KP1=1	B2=GND	starter activated
			B3=GND	

Function	Action	CONDITIONS		
		Necessary	Prohibiting the function	Modifying the function
Accelerator	KA37=1 + YA2=1	SA1 (side I or II) + SB6=1 or SA2=1		



## 2.7.2. DRIVE

Function	Action	CONDITIONS		
		Necessary	Prohibiting the function	Modifying the function
Micro-speed	YV30a=1 or YV30b=1	SA1 (side I) + SB6 = 1	SQ1=0	sensors length SL3-SL4 - SL7- SL8
			G1, G2, A1 and A2 (Overload)	
			YV12=0	
			Head modules Node A/B defective	
			System in overload calibration	
			SQ34 or SQ35 =0	

Function	Action	CONDITIONS		
		Necessary	Prohibiting the function	Modifying the function
Low speed forward	YV30a=1	SA1 (side I) + SWB05=0+ JYB01 wire B100=1 + SB6 = 1 + JYB01y between 2.5V and 0.5V	SQ1=0	YV10 B8 chassis in intermediate position
			G1, G2, A1 and A2 (Overload)	
			SQ34 or SQ35 =0	
			Head modules Node A/B defective	
			System in overload calibration	
			YV12= 0	
Low speed reverse	YV30b=1	SA1 (side I) + SWB05=0+ JYB01 wire B101=1 + SB6 = 1 and JYB01y between 2.5V and 4.5V	SQ1=0	
			G1, G2, A1 and A2 (Overload)	
			SQ34 or SQ35=0	
			Head modules Node A/B defective	
			System in overload calibration	
			YV12= 0	

Function	Action	CONDITIONS		
		Necessary	Prohibiting the function	Modifying the function
High speed forward	YV30a=1 + YV10 = 1	SA1 (side I) + SWB05=1 + JYB01 wire B100 =1 + SB6 = 1 + B8=1 and JYB01y between 2.5V and 0.5V	SQ3, SQ9, SQ10 and SQ11=1	SQ1=0 SQ36 or SQ38 =0 or SQ30 with SQ33 =0 (axles in intermediate position) YV33
			G1, G2, A1 and A2 (Overload)	
			SQ34 or SQ35 =0	
			Head modules Node A/B defective	
			System in overload calibration	
High speed reverse	YV30b=1 + YV10 =1	SA1 (side I) + SWB05 = 1+ JYB01 wire B101 =1 + SB6 = 1 + B8=1 and JYB01y between 2.5V and 4.5V	SQ2, SQ3, SQ9, SQ10 and SQ11=1	SQ1=0 SQ36 or SQ38 =0 or SQ30 with SQ33 =0 (axles in intermediate position) YV33
			G1, G2, A1 and A2 (Overload)	
			SQ34 or SQ35=0	
			Head modules Node A/B defective	
			System in overload calibration	
			YV12= 0	

Note : if axle is not fully extended/retracted, it's possible to drive in High/low speed (only if machine is in stowed position)

Function	Action	CONDITIONS		
		Necessary	Prohibiting the function	Modifying the function
Differential lock	YV9=1	SA1 (side I) + SB6 =1 + SWB07=1	Selection high speed drive SWB05= 0	
			Unfolded machine	
			YV12= 0	

### 2.7.3. STEERING

Function	Action	CONDITIONS		
		Necessary	Prohibiting the function	Modifying the function
Steering front axle	YV 1+ YV2a+ YV21a=1 or YV21b=1	SA1 (side I) + SB6=1 + JYB01 wire B108 or B109=1 +	SQ1=0	YV31=1
			YV12= 0	

Function	Action	CONDITIONS		
		Necessary	Prohibiting the function	Modifying the function
Steering rear axle	YV1 + YV2a + YV22a=1 or YV22b=1	SA1 (side I) + SB6=1 + SWB 06 A1 or A3 =1	SQ1=0	YV31=1
			YV12= 0	

### 2.7.4. BOOM LIFT

Function	Action	CONDITIONS		
		Necessary	Prohibiting the function	Modifying the function
Raise upper control box	YV1=1 + YV4=1	SA1 (side I) + SB6=1 + JYB03 ab=1 and JYB03y between 2.5V and 0.5V	SQ1=0	YV42 = 1
			G1, G2, A1 and A2 (overload)	
			SQ43, SL1, SL2, SL3 and SL4 (reach limitation)	
			Defect CAN-BUS Module B1 node	
			SQ30 to SQ35 + ILS SQ36/SQ38 (axles IN)	
Descent upper control box	YV1=1 + YV4=1 + YV42 =1	SA1 (side I) + SB6=1 + JYB03 ab=1 and JYB03y between 2.5V and 4,5V	SQ1=0	
			G1, G2, A1 and A2 (overload)	
			SQ43, SL1, SL2, SL3 and SL4 (reach limitation)	
			Defect CAN-BUS - module B1 node	
			SQ30 to SQ35 + ILS SQ36/SQ38 (axles IN)	
Raise lower control box	YV1=1 + YV4=1	SA1 (side II) + SA19a = 1 + SA13b=1	SQ1=0	SQ30 to SQ35 + ILS SQ36/SQ38 (axles IN)
			G1, G2, A1 and A2 (Overload)	
			SQ43, SL1, SL2, SL3 and SL4 (reach limitation)	

Descent lower control box	YV1=1 + YV4=1	SA1 (side II) + SA19a = 1 + SA13a=1 +	SQ1=0	Reduced speed if dynamic overload system
			SQ43, SL1, SL2, SL3 and SL4 (reach limitation)	
			SQ30 to SQ35 + ILS SQ36/SQ38 (axles IN)	

### 2.7.5. ARM LIFT

Function	Action	CONDITIONS		
		Necessary	Prohibiting the function	Modifying the function
Raise upper control box	YV1=1 + YV3=1 + YV38=1	SA1 (side I) + YV38 + SB6=1 + JYB02 ab=1 and JYB02 between 2.5V and 0.5V	SQ1=0	SL5, SL7, SL8, SQ44 and SQ45
			G1, G2, A1 A2 (Overload)	
			SQ7 = 1	
			Defect CAN-BUS Module B1 node	
			SQ30 to SQ35 + ILS SQ36/SQ38 (axles IN)	
Descent upper control box	YV1=1 + YV3=1 + YV38=1	SA1 (side I) + YV38 + SB6=1 + SM31ab=1 and SM31y between 2.5V and 4.5V	SQ1=0	SL5, SQ7
			G1, G2, A1 A2 (Overload)	
			SQ43, SL1, SL2, SL3 and SL4 (reach limitation)	
			SL7, SL8, SQ44 and SQ45	
			Defect CAN-BUS Module B1 node	
			SQ30 to SQ35 + ILS SQ36/SQ38 (axles IN)	

Function	Action	CONDITIONS		
		Necessary	Prohibiting the function	Modifying the function
Raise lower control box	YV1=1 + YV3=1 + YV38=1	SA1 (side II) + + SA19a = 1 + SA14b=1	SQ1=0	SL5, SL7, SL8, SQ44 and SQ45
			G1, G2, A1 A2 (Overload)	
			SQ7 = 1	
			SQ30 to SQ35 + ILS SQ36/SQ38 (axles IN)	
Descent lower control box	YV1=1 + YV3=1 + YV38=1	SA1 (side II) + SA19a = 1 + SA14a=1	SQ1=0	SL5, SQ7
			G1, G2, A1 and A2 (Overload)	
			SL7, SL8, SQ44 and SQ45	
			SQ30 to SQ35 + ILS SQ36/SQ38 (axles IN)	



## 2.7.6. TELESCOPING BOOM

Function	Action	CONDITIONS		
		Necessary	Prohibiting the function	Modifying the function
extension upper control box	YV1=1 + YV7=1 + YV41 = 1	SA1 (side I) + SB6=1 + SWB12 = 1 + JYB02ab=1 and JYB02 between 2.5V and 0.5V	SQ1=0	SQ43, SL1, SL2, SL3 and SL4 (reach limitation)
			G1, G2, A1 and A2 (Overload)	
			SQ43 = 0	
			Defect CAN-BUS Module B1 node	
			SQ30 to SQ35 + ILS SQ36/SQ38 (axles IN)	
Retraction upper control box	YV1=1 + YV7=1	SA1 (side I) + SB6=1 + SWB12 = 1 + JYB02 ab=1 and JYB02 between 2.5V and 4.5V	G1, G2, A1 and A2 (Overload)	SQ43, SL1, SL2, SL3 and SL4 (reach limitation)
			Defect CAN-BUS Module B1 node	
			SQ9 = 1	
			SQ30 to SQ35 + ILS SQ36/SQ38 (axles IN)	
			Reduced speed if SQ1=0	
extension lower control box	YV1=1 + YV7=1 + YV41 = 1	SA1 (side II) + SA19a= 1 + SA8b=1	SQ1=0	SQ43, SL1, SL2, SL3 and SL4 (reach limitation)
			G1, G2, A1 and A2 (Overload)	
			SQ30 to SQ35 + ILS SQ36/SQ38 (axles IN)	
Retraction lower control box	YV1=1 + YV7=1	SA1 (side II) + SA19a =1 + SA8a=1	SQ9 = 1	SQ43, SL1, SL2, SL3 and SL4 (reach limitation)
			SQ30 to SQ35 + ILS SQ36/SQ38 (axles IN)	
			Reduced speed if SQ1=0	

### 2.7.7. TELESCOPING ARM

Function	Action	CONDITIONS		
		Necessary	Prohibiting the function	Modifying the function
extension upper control box	YV1=1 + YV6=1+ YV35 then YV36 = 1	SA1 (side I) + SB6=1 + JYB02 ab=1 and JYB02 between 2.5V and 0.5V	SQ1=0	
			G1, G2, A1 and A2 (Overload)	
			SL5 SQ7 =0 (arm not raised)	
			SQ43 = 0 , SL1, SL2, SL3 and SL4 (boom in negative)	
			SQ30 to SQ35 + ILS SQ36/SQ38 (axles IN)	
			Defect CAN-BUS Module B1 node	
Retraction upper control box	YV1=1 + YV6=1 YV35 then YV36 = 1	SA1 (side I) + SB6=1 + JYB02ab=1 and JYB02y between 2.5V and 4.5V	G1, G2, A1 and A2 (Overload)	Reduced speed if SQ1=0  +  SL7, SL8, SQ44 and SQ45 (reach limitation)
			SL5	
			Defect CAN-BUS Module B1 node	
			SQ30 to SQ35 + ILS SQ36/SQ38 (axles IN)	
extension lower control box	YV1=1 + YV6=1	SA1 (side II) =1 + SA19a = 1 + SA14b=1	SQ1=0	
			G1, G2, A1 and A2 (Overload)	
			SL5 SQ7 =0 (arm not raised)	
			SQ43 = 0 SL1, SL2, SL3 and SL4 (boom into negative)	
			SQ30 to SQ35 + ILS SQ36/SQ38 axles IN)	

				- Reduced Speed if SQ1=0 SL7, SL8, SQ44 and SQ45 (reach limitation) - slight telescoping extension in transport with SQ10 = 1
		SA1 (side II) + SA19a=1 + SA14a=1	SQ30 to SQ35 + ILS SQ36/SQ38 (axles IN)	

### 2.7.8. TURRET SLEWING

Function	Action	CONDITIONS		
		Necessary	Prohibiting the function	Modifying the function
Orientation upper control box	YV1=1 + YV5=1 + YV34 = 1	SA1 (side I) + SB6=1 + JYB03 ab=1 and JYB031x between 4.5V and 0.5V	G1, G2, A1 and A2 (Overload)	
			SQ30 to SQ35 + ILS SQ36/SQ38 (axles IN) Defect CAN-BUS Module B1 node	
Orientation lower control box	YV1=1 + YV5=1 + YV34 = 1	SA1 (side II) + SA19a = 1 + SA15a=1 or SA15b=1	SQ30 to SQ35 + ILS SQ36/SQ38 (axles IN or OUT)	

### 2.7.9. ARM/LINK PART COMPENSATION

Function	Action	CONDITIONS	
		Necessary	Prohibiting the function
Arm/link part compensation (front shifting)	YV1=1 + YV40=1	SL5 < 3° + ILS SQ27= 0+ descent arm in progress	defect on arm movement
			Module node A
Arm /link part compensation (rear shifting)	YV1=1 + YV27=1	SL5 < 10° + ILS SQ27= 1 + descent arm in progress	Module node A

### 2.7.10. RELEASING OSCILLATING AXLE

Function	Action	CONDITIONS		
		Necessary	Prohibiting the function	Modifying the function
Releasing oscillating axle	YV33=1	Machine stowed Function drive activated	SQ40=0	

## 2.7.11. JIB

Function	Action	CONDITIONS		
		Necessary	Prohibiting the function	Modifying the function
Raise upper control box	YV1=1 + YV2b=1 + YV18b=1	SA1 (side I) + SB6=1 and SWB11A1=1	SQ1=0	
			G1, G2, A1 and A2 (Overload)	
			Defect CAN-BUS Module B1 node	
Descent upper control box	YV1=1 + YV2a=1 + YV18a=1	SA1 (side I) + SB6=1 and SWB11A3=1	SQ1=0	
			G1, G2, A1 and A2 (Overload)	
			Defect CAN-BUS Module B1 node	
Raise lower control box	YV1=1 + YV2b=1 + YV18b=1	SA1 (side II) + SA19a = 1 + SA6a=1	Defect CAN-BUS Module B1 node	Reduced speed if  SQ1=0
Descent lower control box	YV1=1 + YV2a=1 + YV18a=1	SA1 (side II) + SA19a = 1 + SA6b=1		or  G1, G2, A1 and A2 (Overload)



## 2.7.12. COMPENSATION

Function	Action	CONDITIONS		
		Necessary	Prohibiting the function	Modifying the function
Raise upper control box	YV1=1 + YV2a=1 + YV15a=1	SA1 (side I) + SB6=1 + SWB03A1=1	G1, G2, A1 and A2 (Overload)	Reduced speed if SQ1=0
			Any other movement in progress Defect CAN-BUS Module B1 node	
Descent upper control box	YV1=1 + YV2b=1 + YV15b=1	SA1 (side I) + SB6=1 + SWB03A3=1	G1, G2, A1 and A2 (Overload)	
			Any other movement in progress Defect CAN-BUS Module B1 node	
Raise lower control box	YV1=1 + YV2a=1 + YV15a=1	SA1 (side II) + SA19a = 1 + SA21b=1	G1, G2, A1 and A2 (Overload)	
			Any other movement in progress	
			SQ9 and SQ10=0	
			SQ2=0	
Descent lower control box	YV1=1 + YV2b1 + YV15b=1	SA1 (side II) + SA19a = 1 + SA21a=1	G1, G2, A1 and A2 (Overload)	
			Any other movement in progress	
			SQ9 and SQ10=0	
			SQ2=0	

### 2.7.13. BASKET ROTATION

Function	Action	CONDITIONS		
		Necessary	Prohibiting the function	Modifying the function
Rotation right/left upper control box	YV1=1 + YV2a/b=1 + YV19b=1	SA1 (side I or II) + SB6=1 and SWB13A1/A3=1	Defect CAN-BUS Module B1 node	Reduced speed if SQ1=0 Or G1, G2, A1 and A2 (Overload)

### 2.7.14. EXTENSION AXLES AND BLOCKING

Function	Action	CONDITIONS		
		Necessary	Prohibiting the function	Modifying the function
Extension or retraction front axle	YV1=1 + YV2a=1	SA1 in central position + engine running + YV8=1 + YV31=1		SQ31 to SQ35 + ILS SQ36/SQ38
			SQ1=0	
Extension or retraction rear axle	YV1=1 + YV2a=1	SA1 in central position + engine running +YV8=1 + YV31=1		
			SQ1=0	
			Unfolded and machine not aligned (SQ40 + SQ42 =0)	
			Unfolded and machine not aligned (SQ40 + SQ42 =0)	

### 3. THE HYDRAULIC PART

---

#### 3.1. THE HYDRAULIC SCHEMATICS

See all versions at the end of this manual

#### 3.2. VALVES LOCATION



### 3.3. HYDRAULIC PUMPS

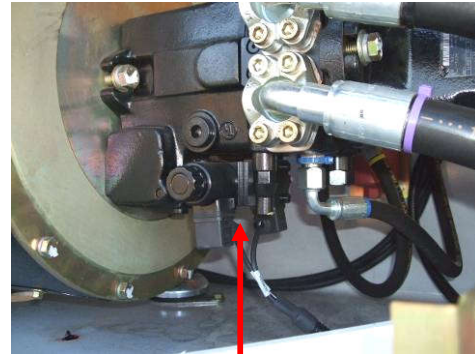
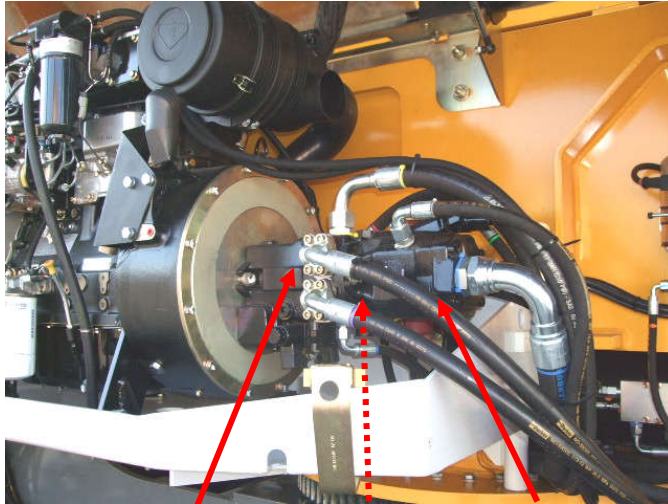
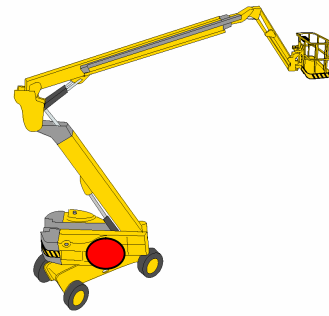

Drive pump      Equipment pump

Charge pump (internal)

YV30A/B proportional PWM valves for FWD/REV drive

Note : Electrovalve PWM type : (Pulse Width Modulation) valve with square modulated signal in output with current regulation



#### 3.3.1. DRIVE PUMP

System in closed loop equipped with a pump with variable cubic capacity and two directions of flow to proportional control (YV30 a/b).  
The pump supplies in parallel the 4 motors with double cubic capacity (45/15 cc).  
The charge pump (8.4 cc) supplies the circuit and compensates the leaks of the system.

#### 3.3.2. EQUIPMENT PUMP

System in open circuit equipped with a variable load sensing pump  
The pump delivers oil for all the movements

### 3.4. CYLINDERS (TURRET)

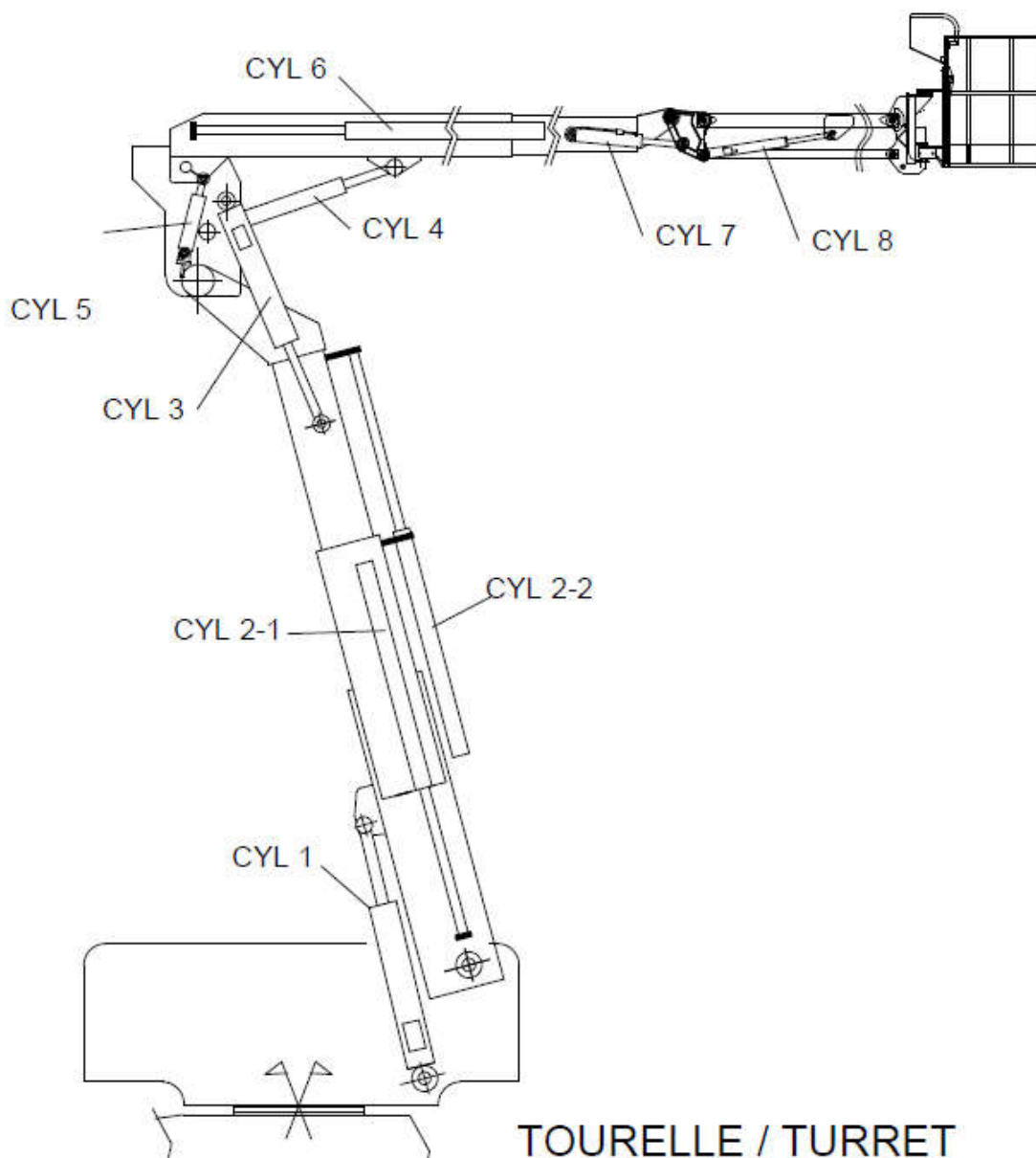

LIST	DESCRIPTION
CYL 1	Lifting arm
CYL 2-1	Telescoping arm 1
CYL 2-2	Telescoping arm 2
CYL 3	Compensation link part
CYL 4	Boom lift
CYL 5	Compensation emitter
CYL 6	Telescoping boom
CYL 7	compensation receptor
CYL 8	jib lifting



### 3.5. MAIN MANIFOLD

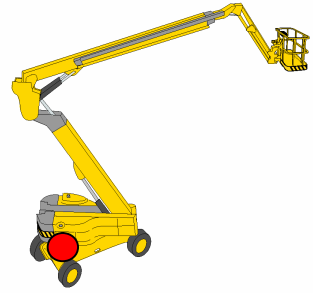

#### 3.5.1. HYDRAULIC BLOCK IN CHASSIS ( FRONT PART )



<b>A</b>	Drive block	(High Speed drive, differential lock, brake release)
<b>B</b>	Block steering/movements axles	Steering + releasing of the front axle oscillating
<b>C</b>	Hydraulic valve	Detection of the good positioning of the turret (centered) for movement of the axles

3.5.1.1. Drive block

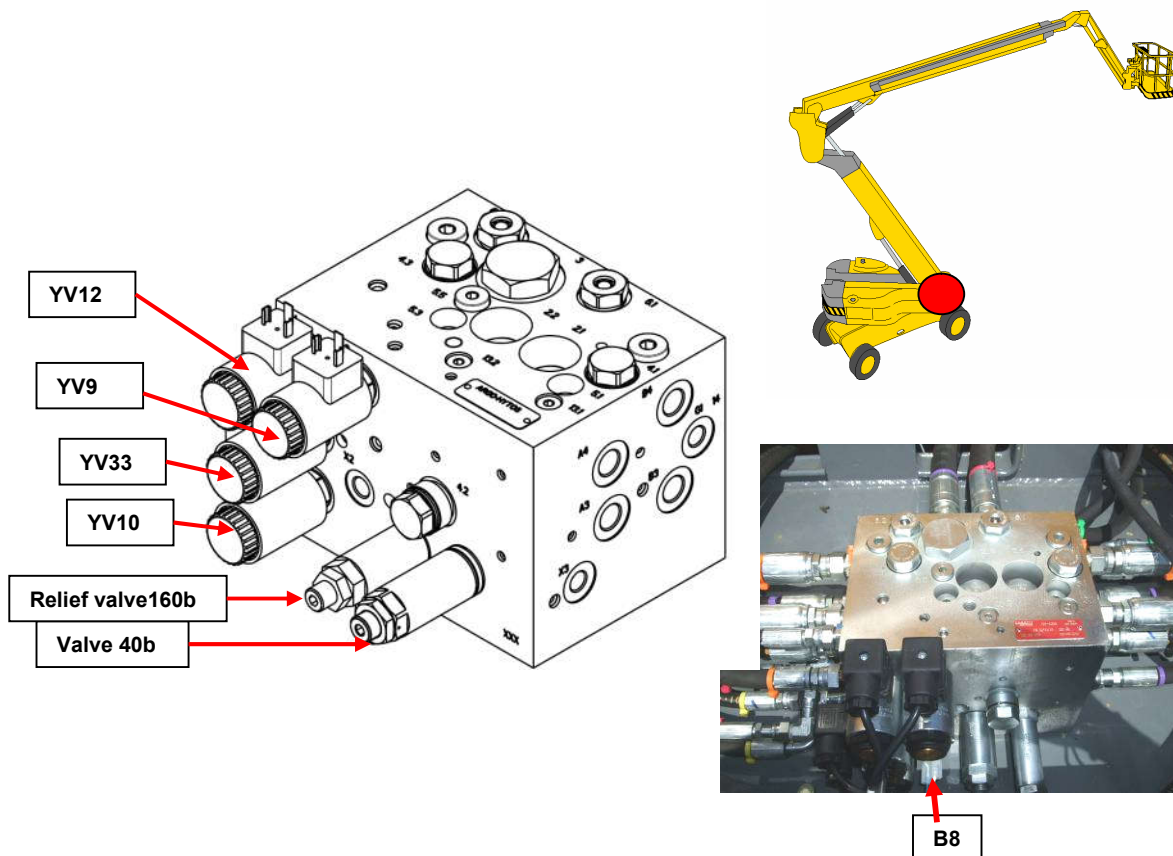

<b>YV12</b>	Brake release of the 4 drive reducers
<b>YV9</b>	differential lock
<b>YV10</b>	Change of cubic capacity of the motors (Low Speed = big cubic capacity) (High Speed = small cc)
<b>Valve 40b</b>	Automatic activation of the swing axle in drive if P > 40b
<b>Relief valve 160b</b>	Pressure relief valve (160 bars) for the piloting of the cubic capacity change
<b>B8</b>	Pressure switch High speed drive (opens at 14 bars if still in HS drive and machine unfolded ie when YV10 spool remains stuck)
<b>YV33</b>	Releasing axles oscillating

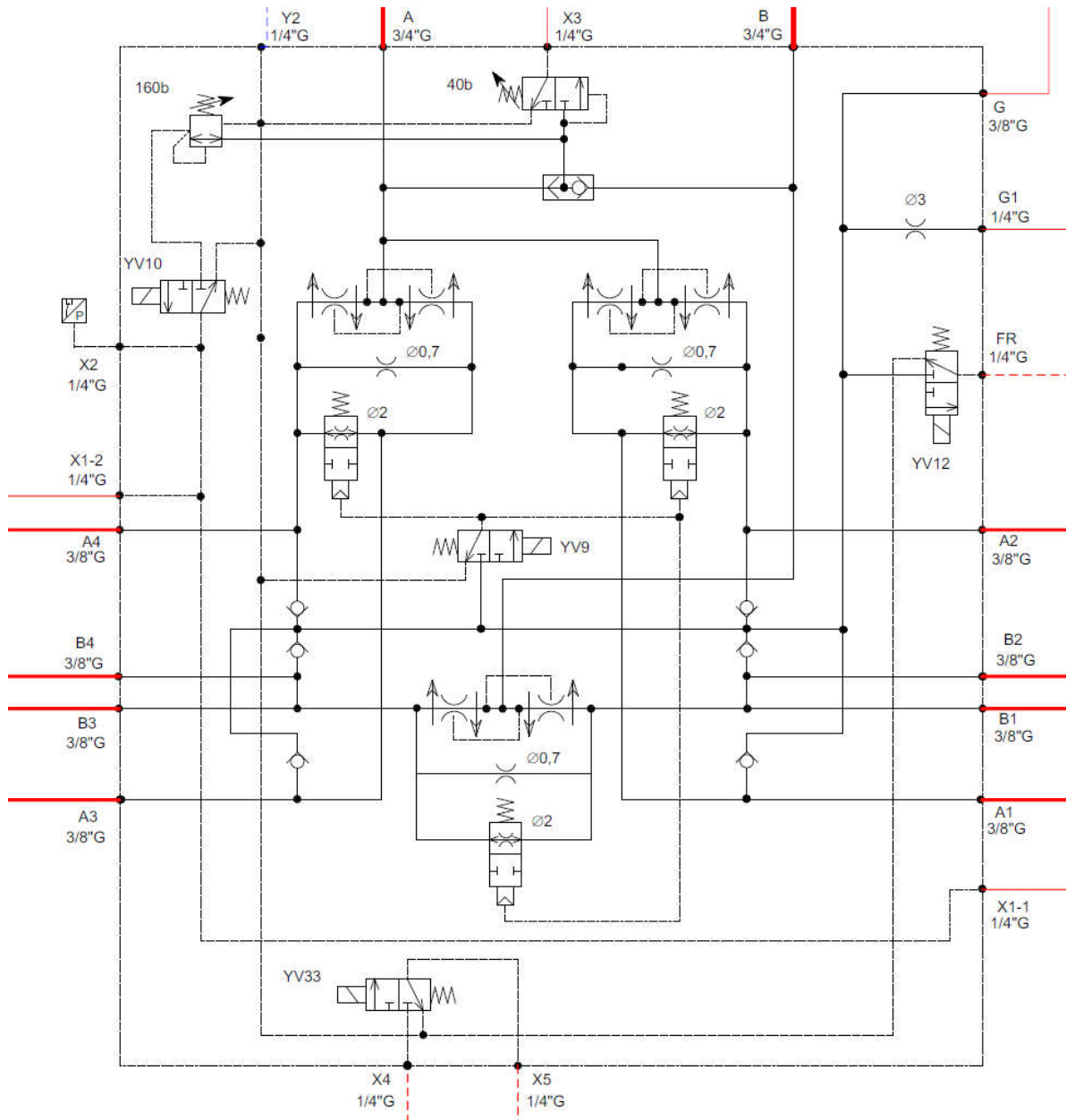

**3.5.1.2. Block for brake release/steering/ axles movements**

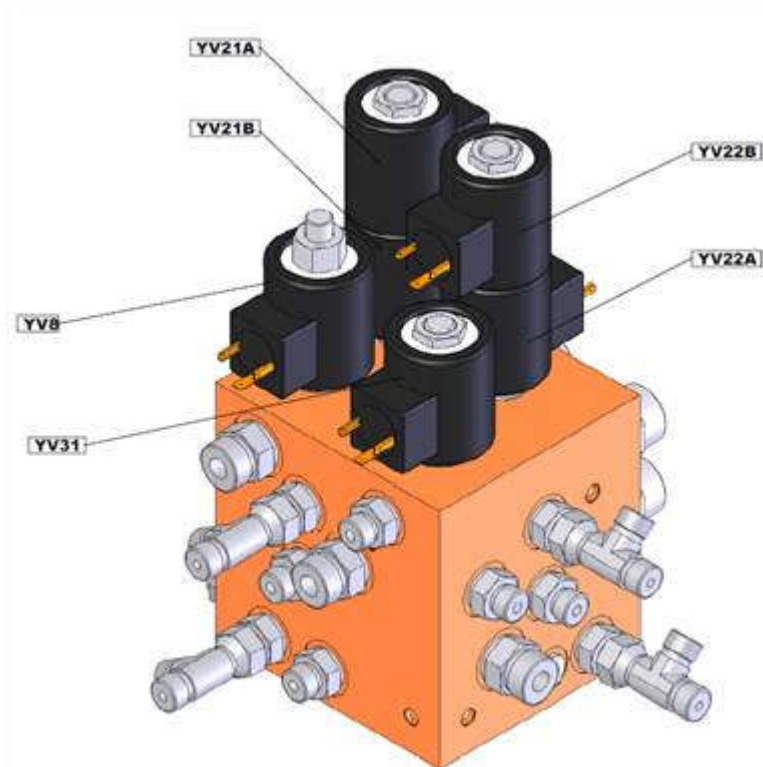
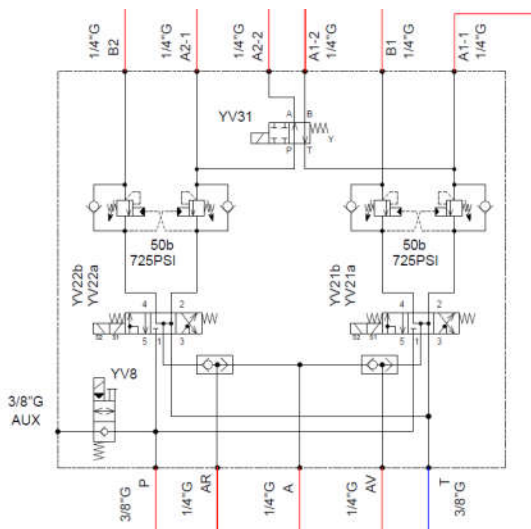

Function of this block :

- Steering front axle with brake release of the associated axle (YV21)
- Steering rear axle with brake release of the associated axles (YV22)

### 3.5.2. HYDRAULIC BLOCK (REAR CHASSIS)

#### 3.5.2.1. Block 13

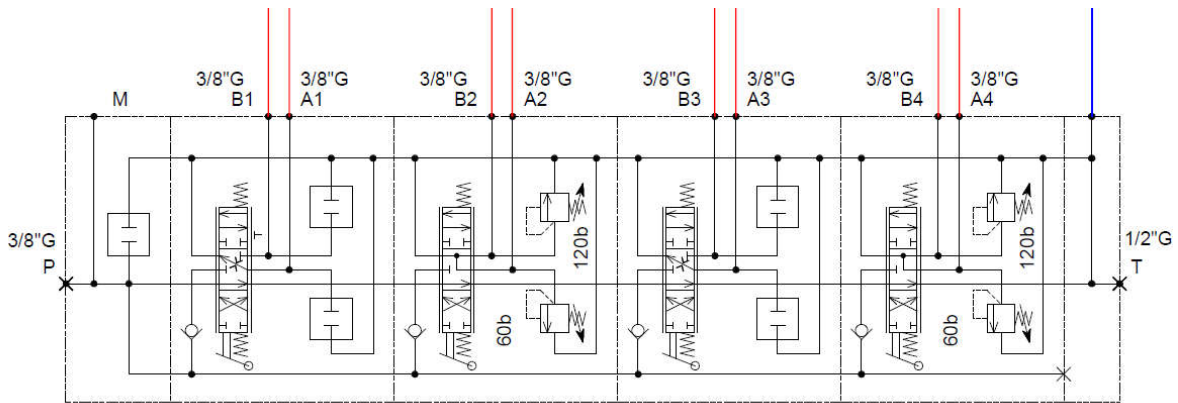
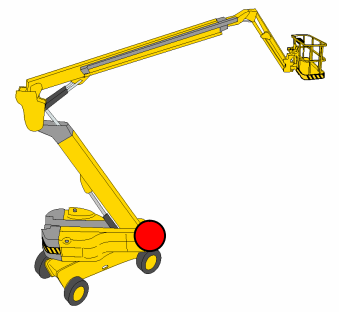

Function of the block:

- Activation of the stabilizing cylinders (black levers)
- extend or retract the axles (yellow levers)

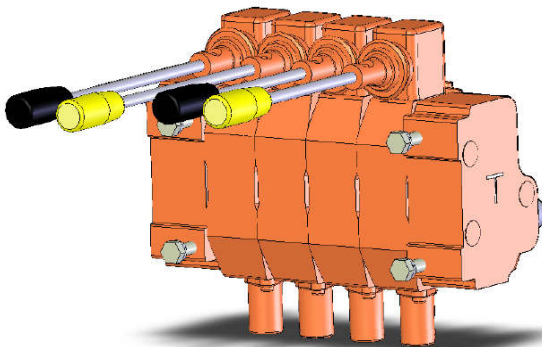



### 3.5.3. TURRET BLOCKS

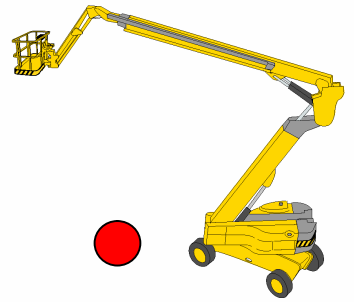

#### 3.5.3.1. PVG

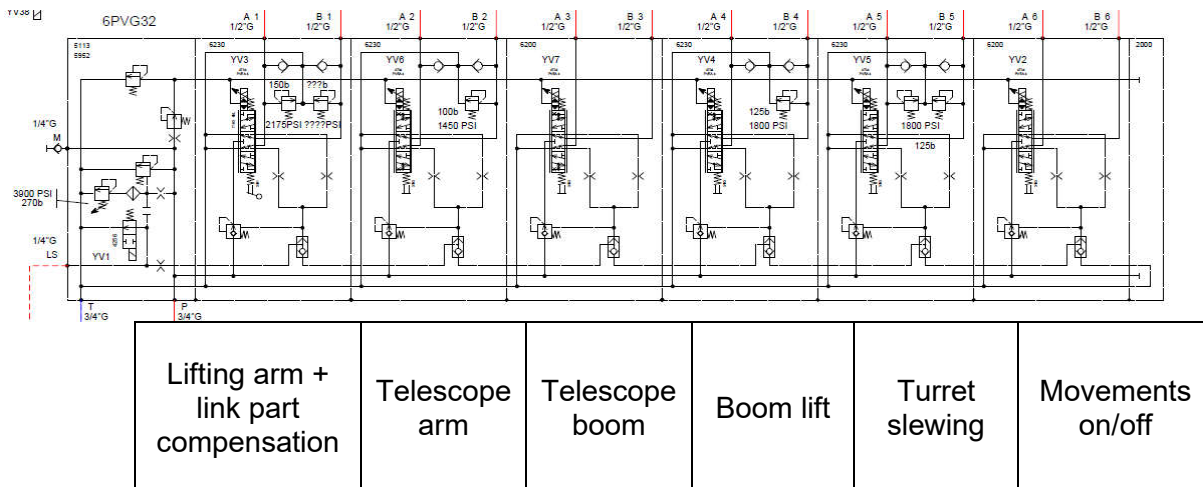
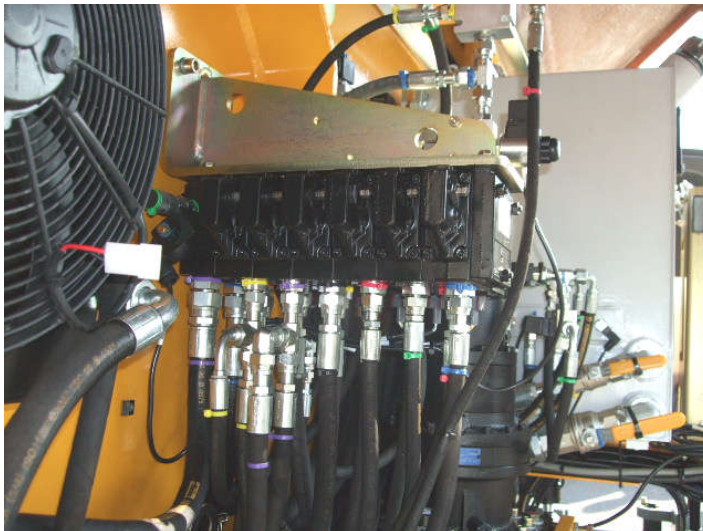
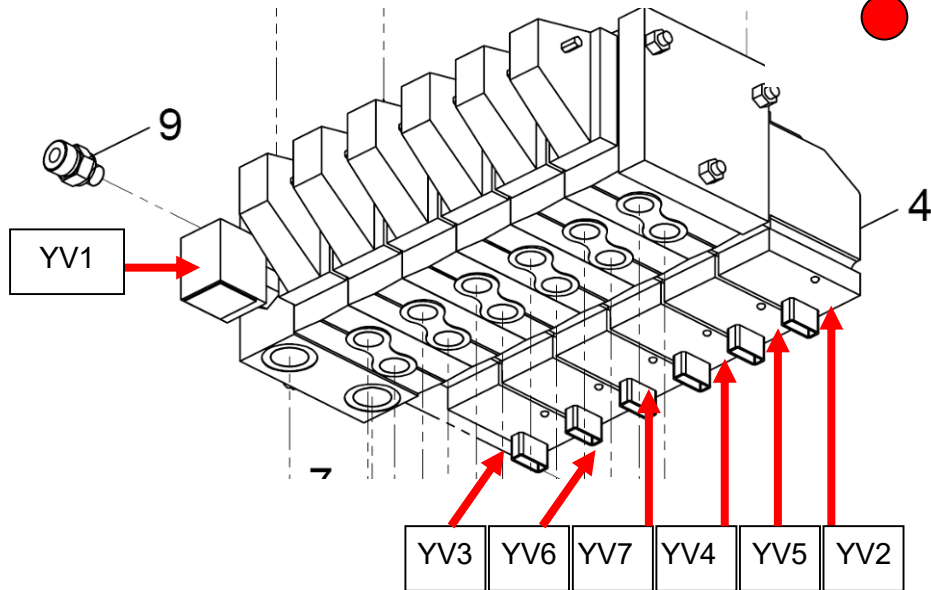

3.5.3.2. Block ON/OFF

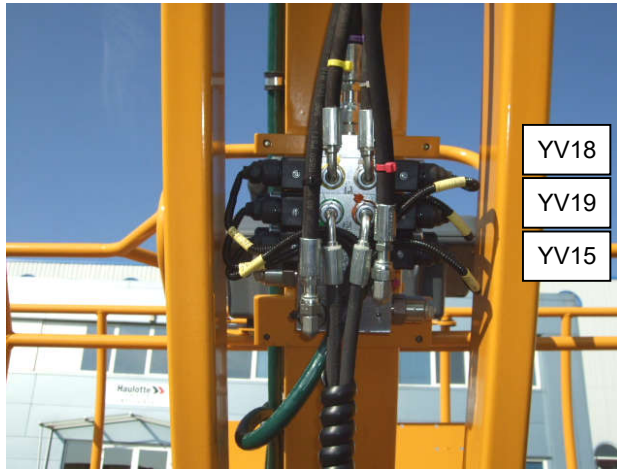
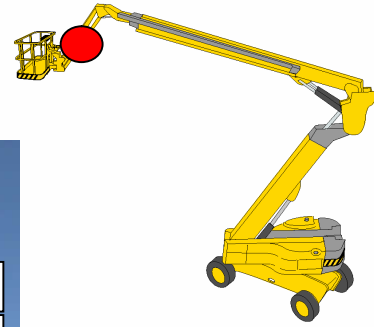

YV18A/B	YV19A/B	YV15A/B
jib	Basket rotation	Basket Compensation

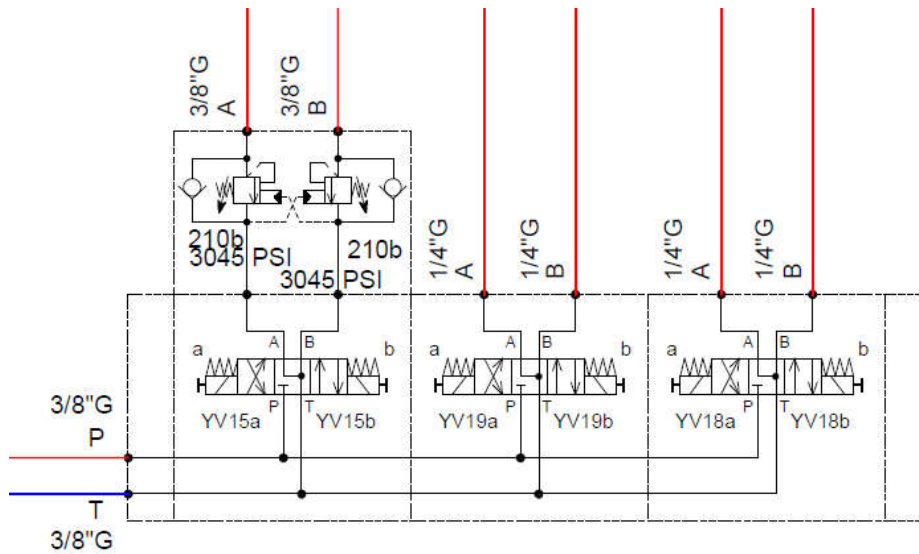

**3.5.3.3. Turret slewing (YV34)**

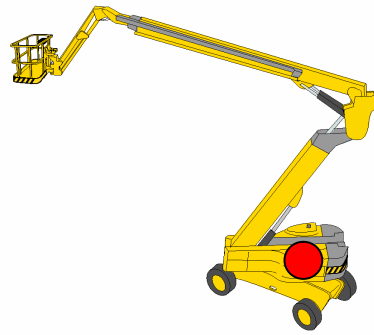
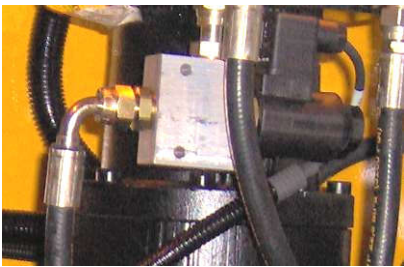

This valve (opened when not used) cuts the oil flow in order to send all the required pressure to the turret motor and avoids unexpected movements

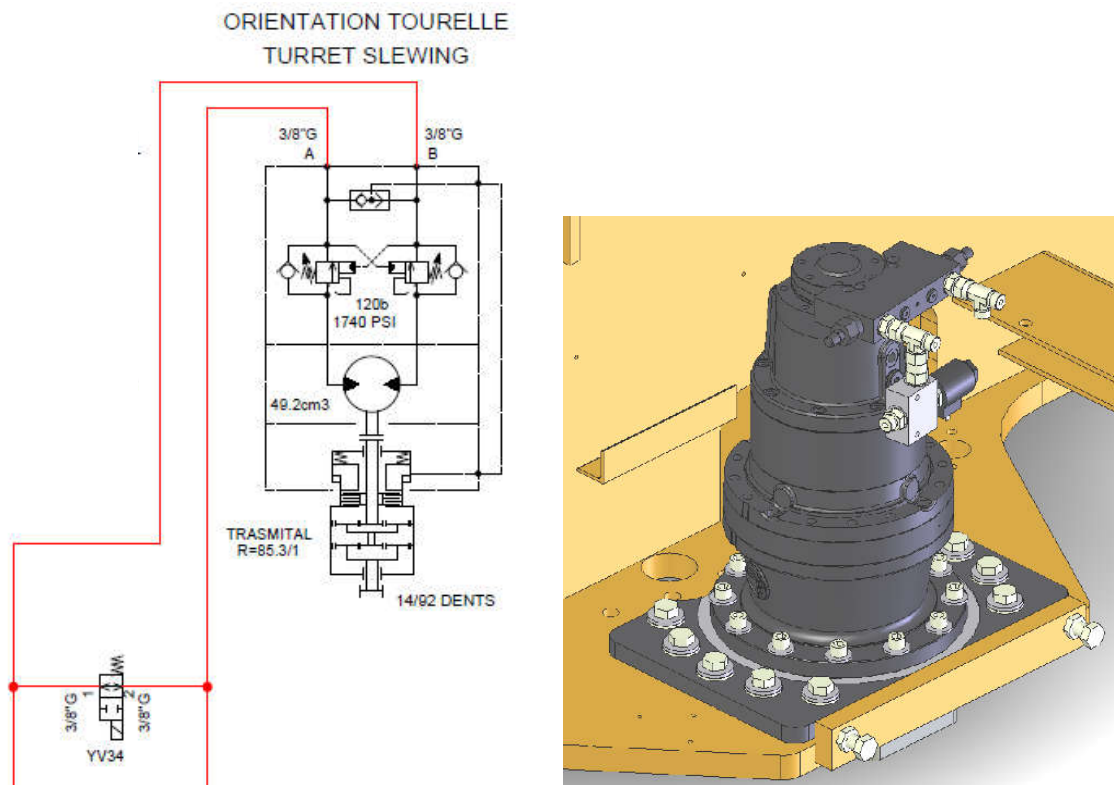

Brake release is ensured by the circuit selector switch in order to avoid non expected movements due to possible remaining pressure in the system

### 3.5.3.4. Safety valves for movements

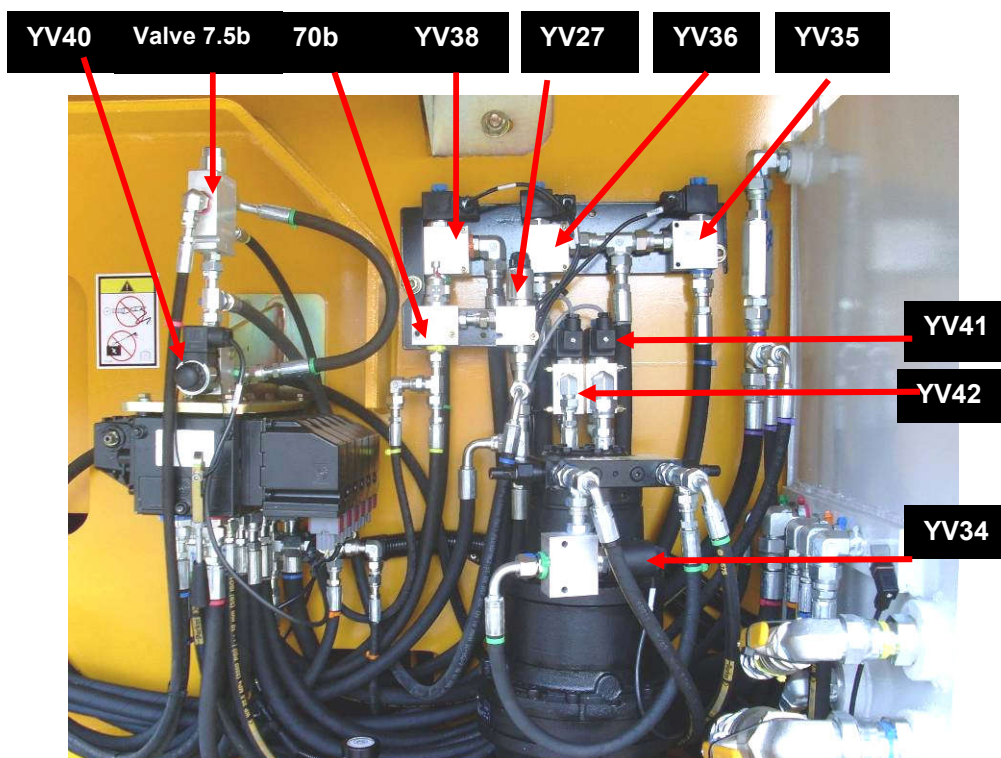

VALVES	DESCRIPTION
YV27	Arm/link part compensation
YV34	Turret slewing
YV35	extension telescope arm 1
YV36	extension telescope arm 2
YV38	Lifting arm
YV40	link part compensation
YV41	telescopic boom extension
YV42	boom descent
piloted valve 7.5b	Authorization arm descent if counterbalance valves lock the compensation part
Relief valve 70b	Safety arm descent if link part arrives at bottom position before the arm



### 3.5.3.5. Synchronization of boom movement

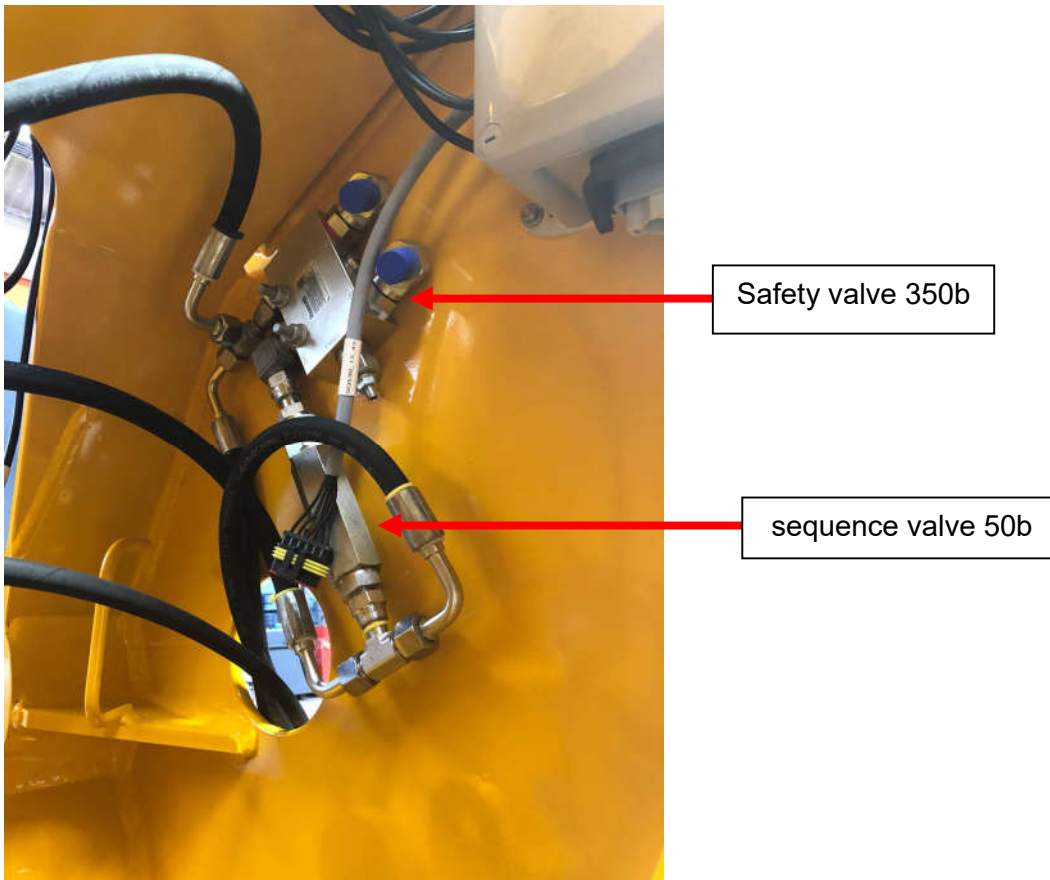

The safety valve 350b holds the load during boom descent

The sequence valve 50b avoids the phenomena of pumping (jerky movements) during the boom descent and thus a possible out of synchronization.

## 3.6. HELP GUIDE FOR HYDRAULIC LEAKS

The next diagram will help the technician to search for hydraulic leaks on hoses  
Each page describes a specific function indicated in red (ex arm lift)  
In order to detect the leaks, it's necessary to activate the command at full stroke



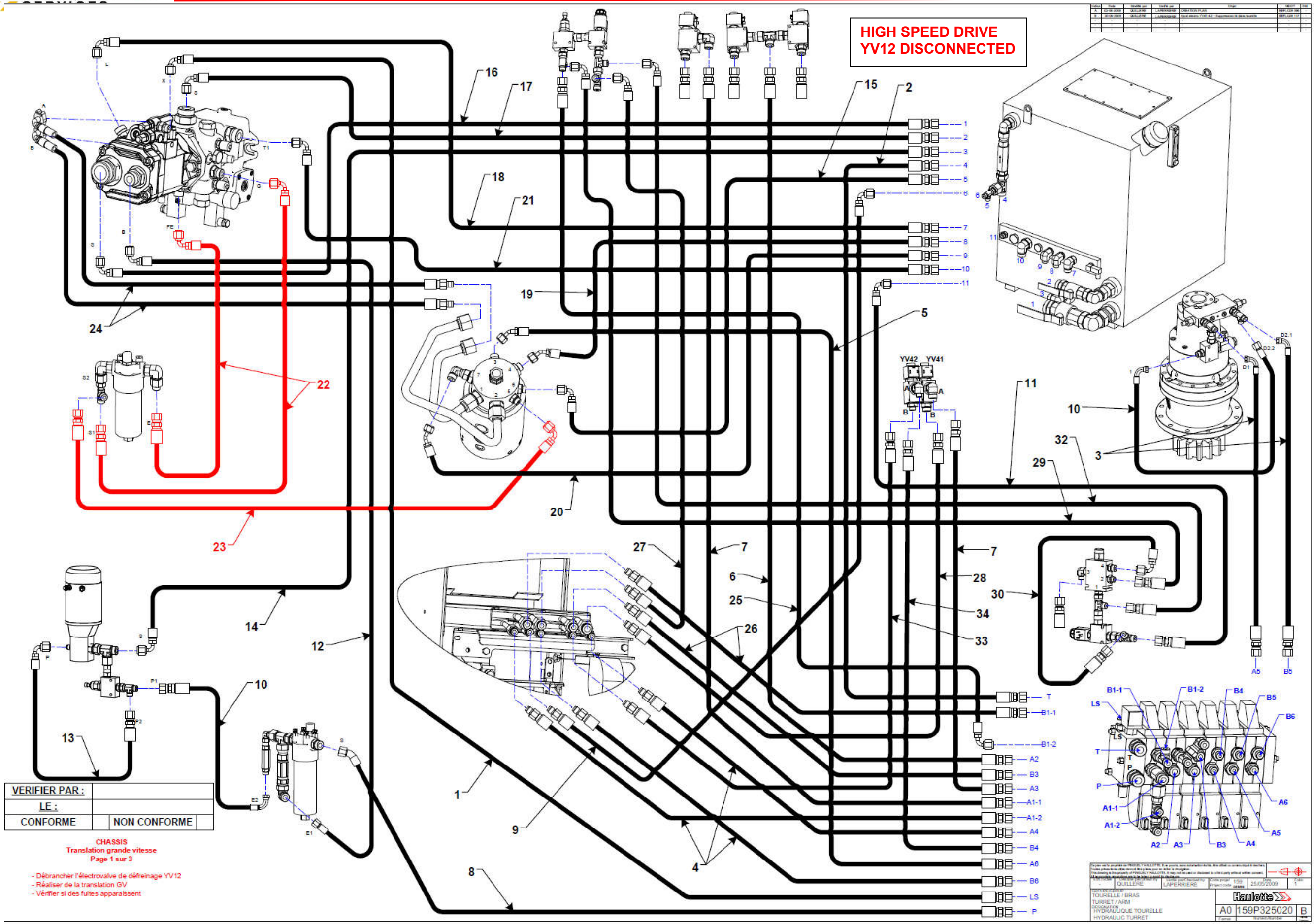

VERIFIER PAR :	
LE :	
CONFORME	NON CONFORME

CHASSIS  
Translation grande vitesse  
Page 1 sur 3

- Débrancher l'électrovalve de défreinage YV12
- Réaliser de la translation GV
- Vérifier si des fuites apparaissent

QUILLÈRE	LAPERMIÈRE	25/05/2009	1
TOURELLE / BRAS TURRETT / ARM RESISTOR HYDRAULIQUE TOURELLE HYDRAULIC TURRET			
A0 159P325020		B	



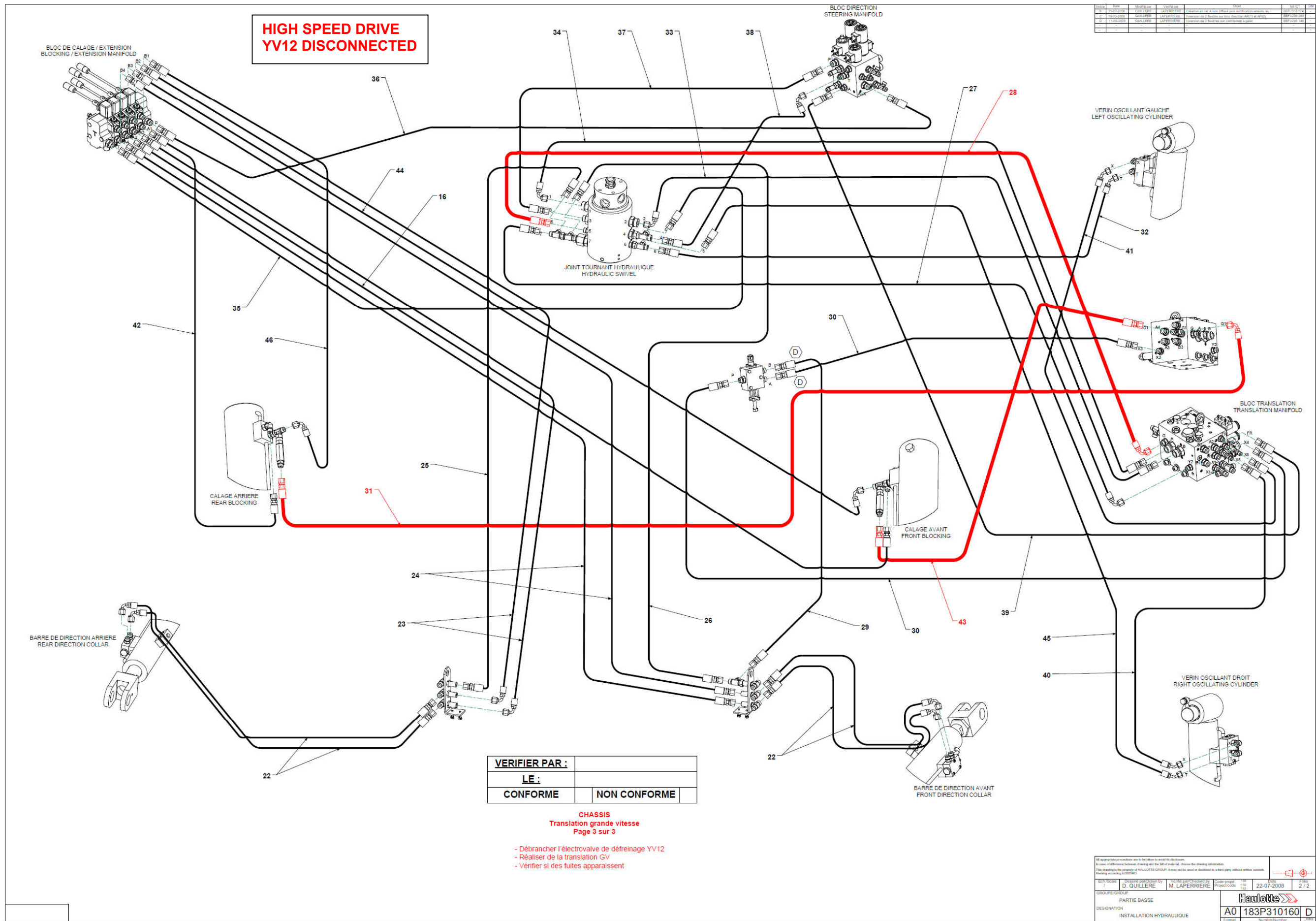

**HIGH SPEED DRIVE  
YV12 DISCONNECTED**

REV.	DATE	MODIF. PAR	VERIFIE PAR	OBJET	REVISION
1	15-03-2008	QUILLERE	LAPERIERRE	Installation de la barre de direction avant et de la barre de direction arrière	183P310160 D
2	15-03-2008	QUILLERE	LAPERIERRE	Installation de la barre de direction avant et de la barre de direction arrière	183P310160 D
3	15-03-2008	QUILLERE	LAPERIERRE	Installation de la barre de direction avant et de la barre de direction arrière	183P310160 D

<b>VERIFIER PAR :</b>	
<b>LE :</b>	
<b>CONFORME</b>	<b>NON CONFORME</b>

**CHASSIS**  
Translation grande vitesse  
Page 3 sur 3

- Débrancher l'électrovalve de défreinage YV12
- Réaliser de la translation GV
- Vérifier si des fuites apparaissent

All appropriate procedures are to be taken to avoid the following: In case of difference between drawings and the set of materials, always the drawing information. This drawing is the property of HAULOTTE GROUP. It may not be used or disclosed to a third party without written consent. Marking according to ISO 9001			
DESIGNER D. QUILLERE	DESIGNATION PARTIE BASSE	VERIFIEE PAR M. LAPERRIERRE	DATE 22-07-2008
GROUPES/GRUPOU PARTIE BASSE	DESIGNATION INSTALLATION HYDRAULIQUE	PROJET A0 183P310160 D	REV. 2 / 2



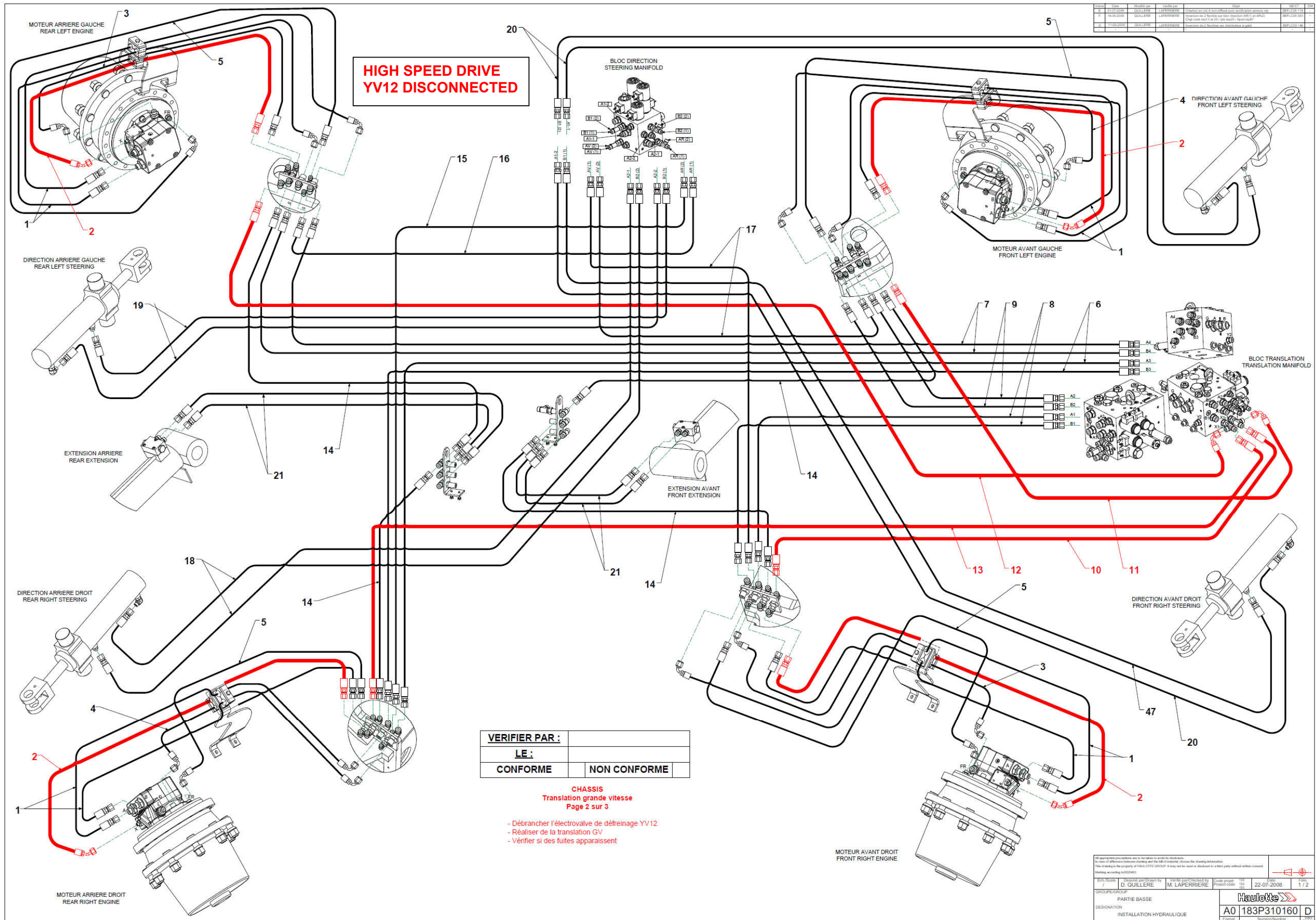

Rev.	Date	Modifié par	Vérifié par	Etat	REVISION
1	15-03-2008	OUILLERE	LAPERRIERE	Revisions des plans de montage et de maintenance	REV.001.1.1
2	15-03-2008	OUILLERE	LAPERRIERE	Suppression de la notice de montage de l'axe de direction	REV.001.1.2
3	15-03-2008	OUILLERE	LAPERRIERE	Suppression de la notice de montage de l'axe de direction	REV.001.1.3

  

<small>All appropriate precautions are to be taken to avoid the risk of injury.</small> <small>In case of difference between drawings and the bill of material, always the drawing information.</small> <small>This drawing is the property of HAULOTTE GROUP. It may not be used or disclosed to a third party without written consent.</small> <small>Respecter les consignes de sécurité.</small>				
<small>Rev. No</small> 7	<small>Revised by</small> D. OUILLERE	<small>Verifié par</small> M. LAPERRIERE	<small>Date</small> 22-07-2008	<small>Page</small> 1/72
<small>GROUP/GRUPPE</small> PARTIE BASSE		<small>Designation</small> INSTALLATION HYDRAULIQUE		
<small>Designation</small> A0 183P310160		<small>Formet</small> 		



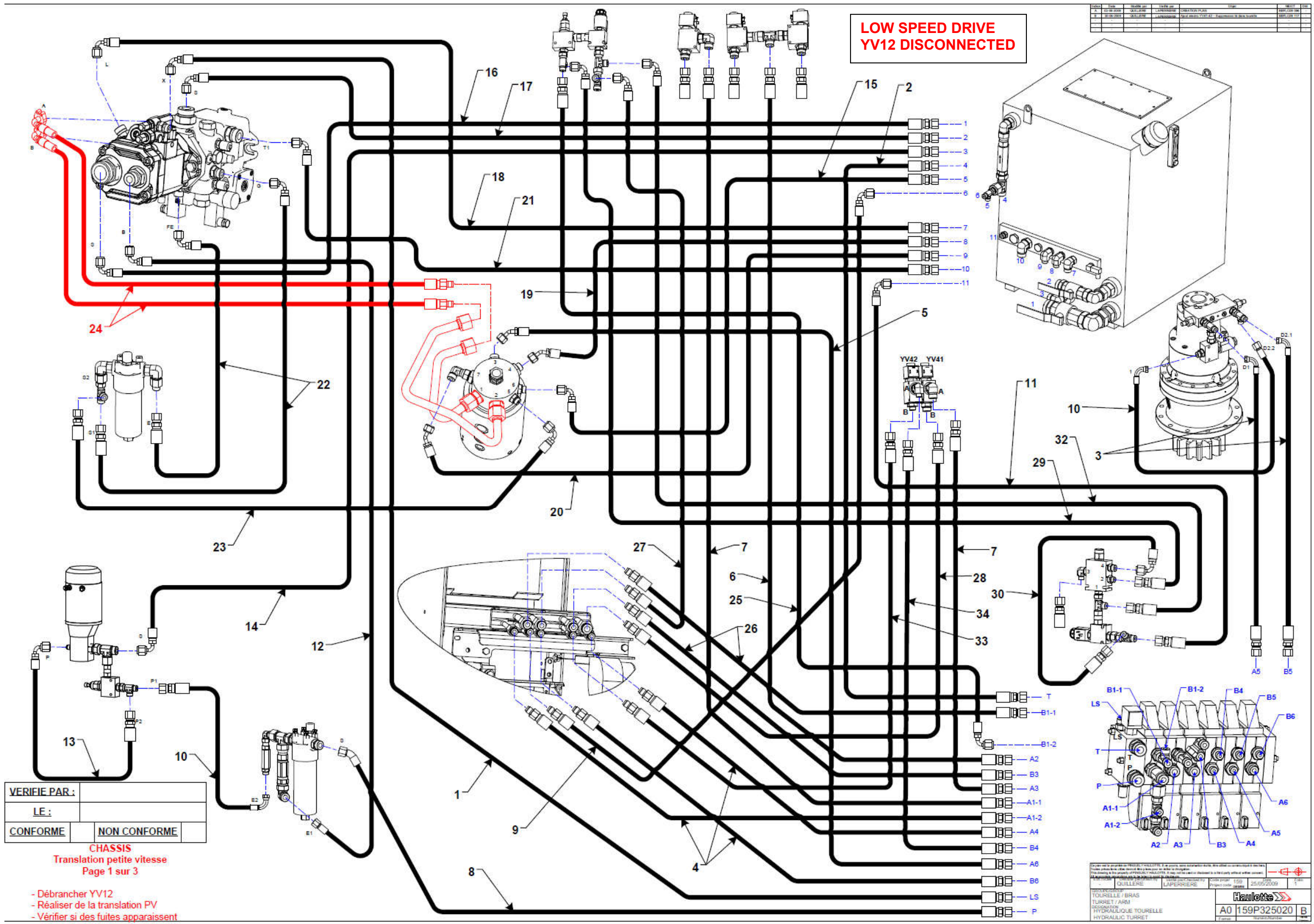



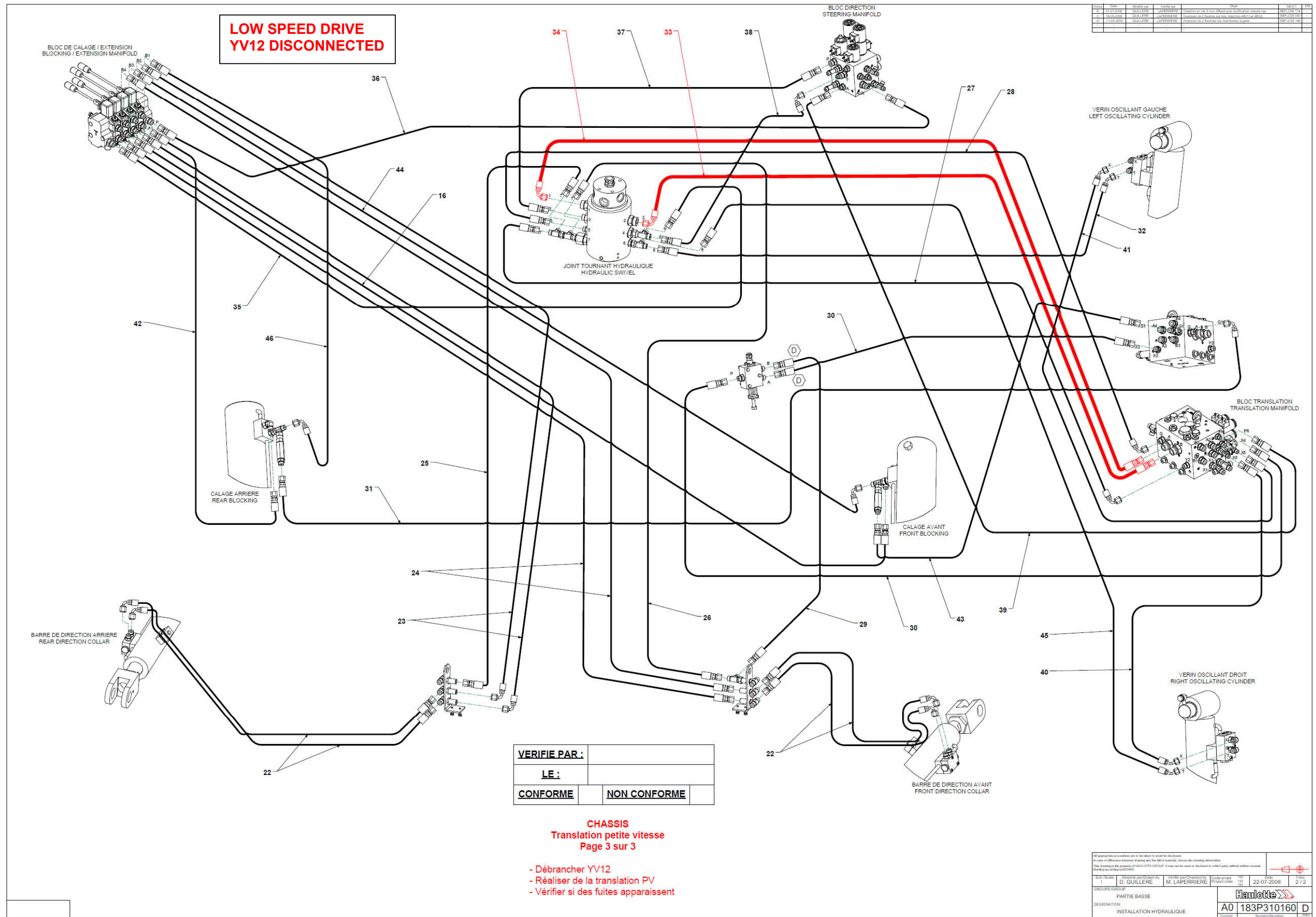

**LOW SPEED DRIVE  
YV12 DISCONNECTED**

Rev.	Date	Modifié par	Validé par	Objet	MR
1	11-03-2008	D. QUILLERE	M. LAPERRIERE	Installation des 2 vérins pour translation avant et arrière	DEF 1138 104
2	15-03-2008	D. QUILLERE	M. LAPERRIERE	Installation des 2 vérins pour direction AVANT et ARRIERE	DEF 1138 104
3	11-03-2008	D. QUILLERE	M. LAPERRIERE	Installation des 2 vérins pour distribution à gauche	DEF 1138 104

VERIFIE PAR :	
LE :	
CONFORME	NON CONFORME

**CHASSIS**  
Translation petite vitesse  
Page 3 sur 3

- Débrancher YV12
- Réaliser de la translation PV
- Vérifier si des fuites apparaissent

All appropriate precautions are to be taken to avoid the following:  
 - Risk of electric shock when working with the H.P. of electrical systems. Always use the correct safety instructions.  
 - Risk of injury to the property of HAULOTTE GROUP. It may not be used or modified in a third party without written consent.  
 - Working pressure: 250/300 BAR

REV. / Scale	7	Developed by / Dessiné par	D. QUILLERE	Validated by / Validé par	M. LAPERRIERE	Date / Date	22-07-2008	Page / Page	2 / 2
GROUP / GROUPE	GROUP	PARTIE BASSE			<b>A0   183P310160   D</b>				
DESIGNATION	INSTALLATION HYDRAULIQUE				<b>A0   183P310160   D</b>				



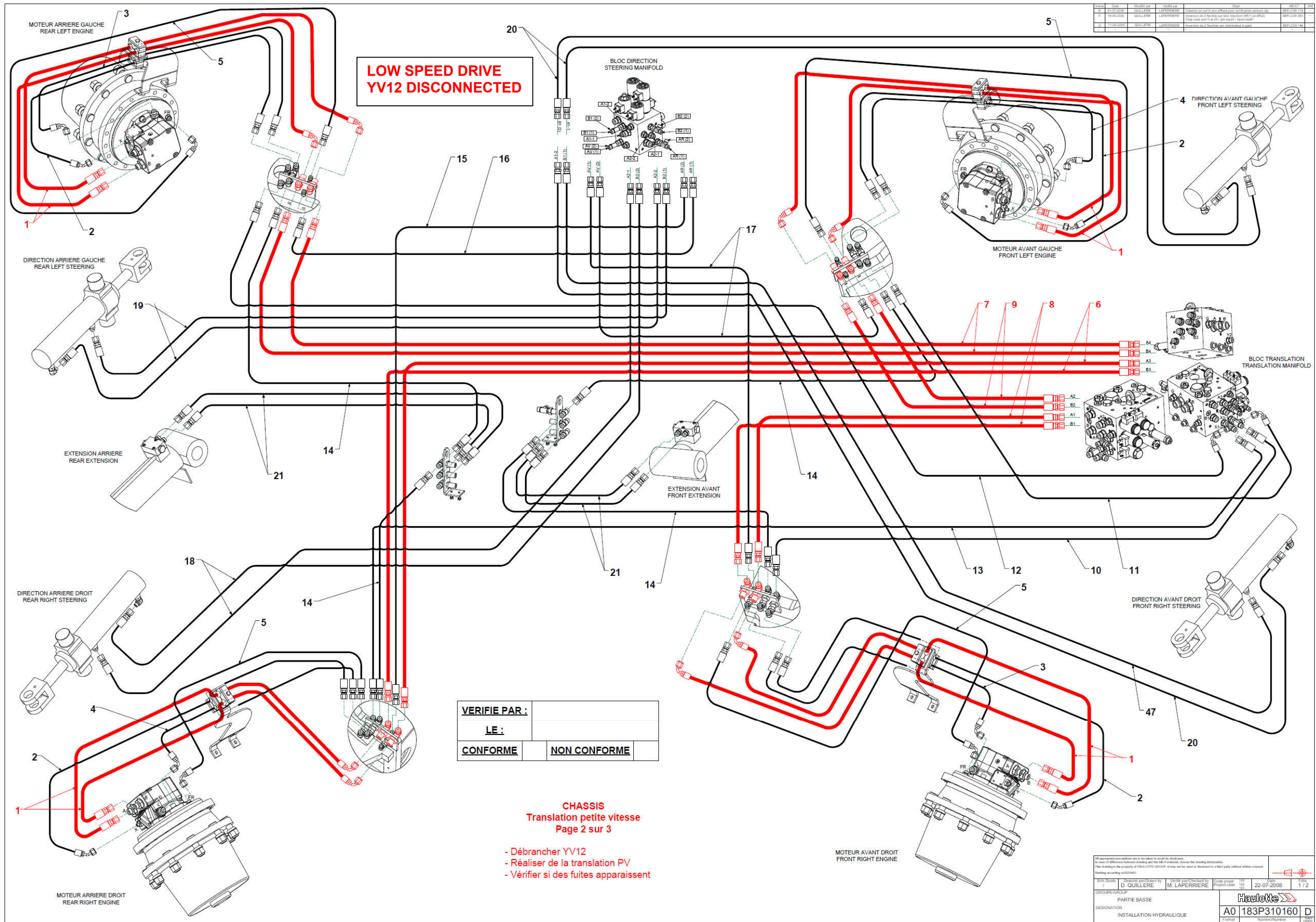



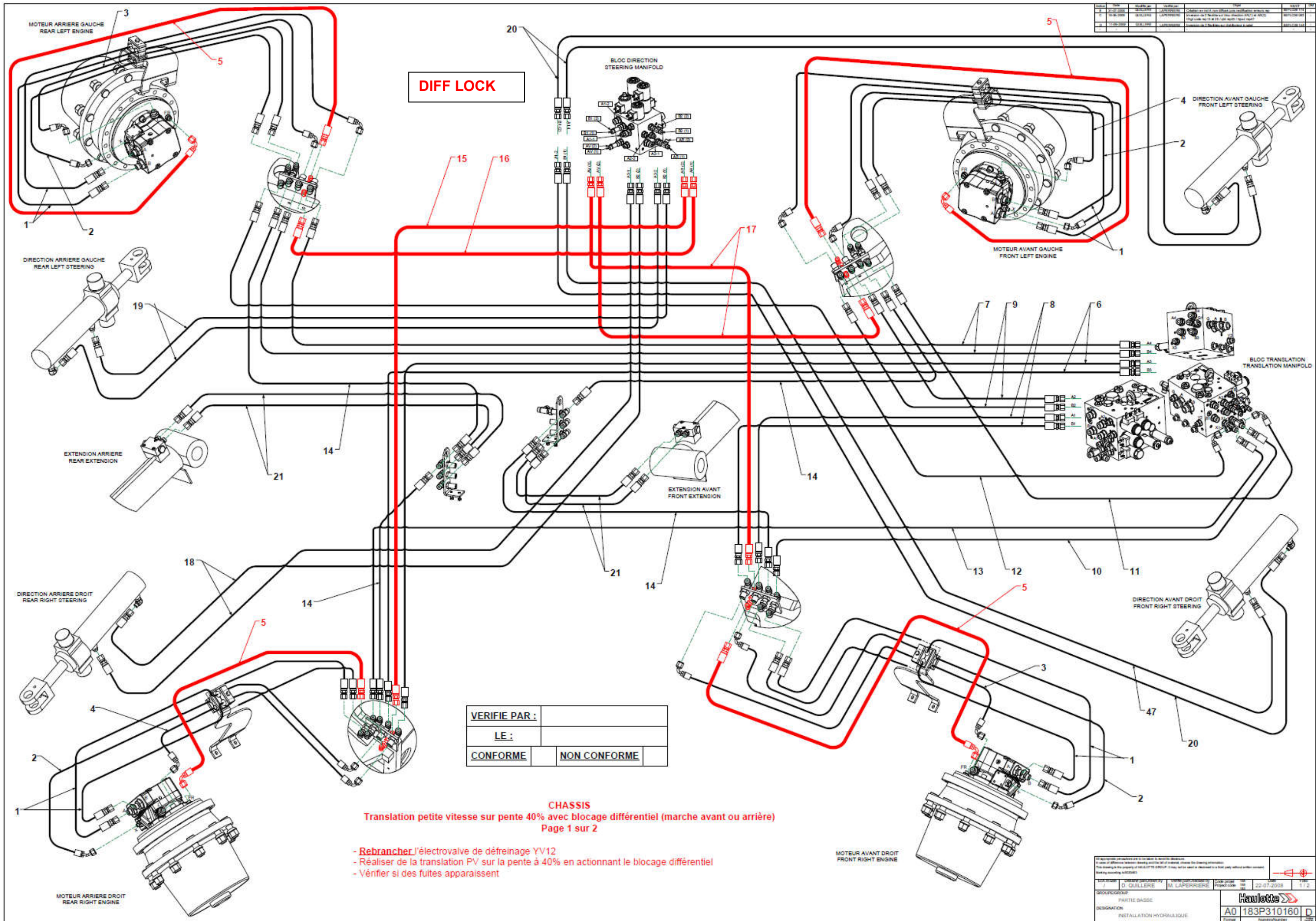



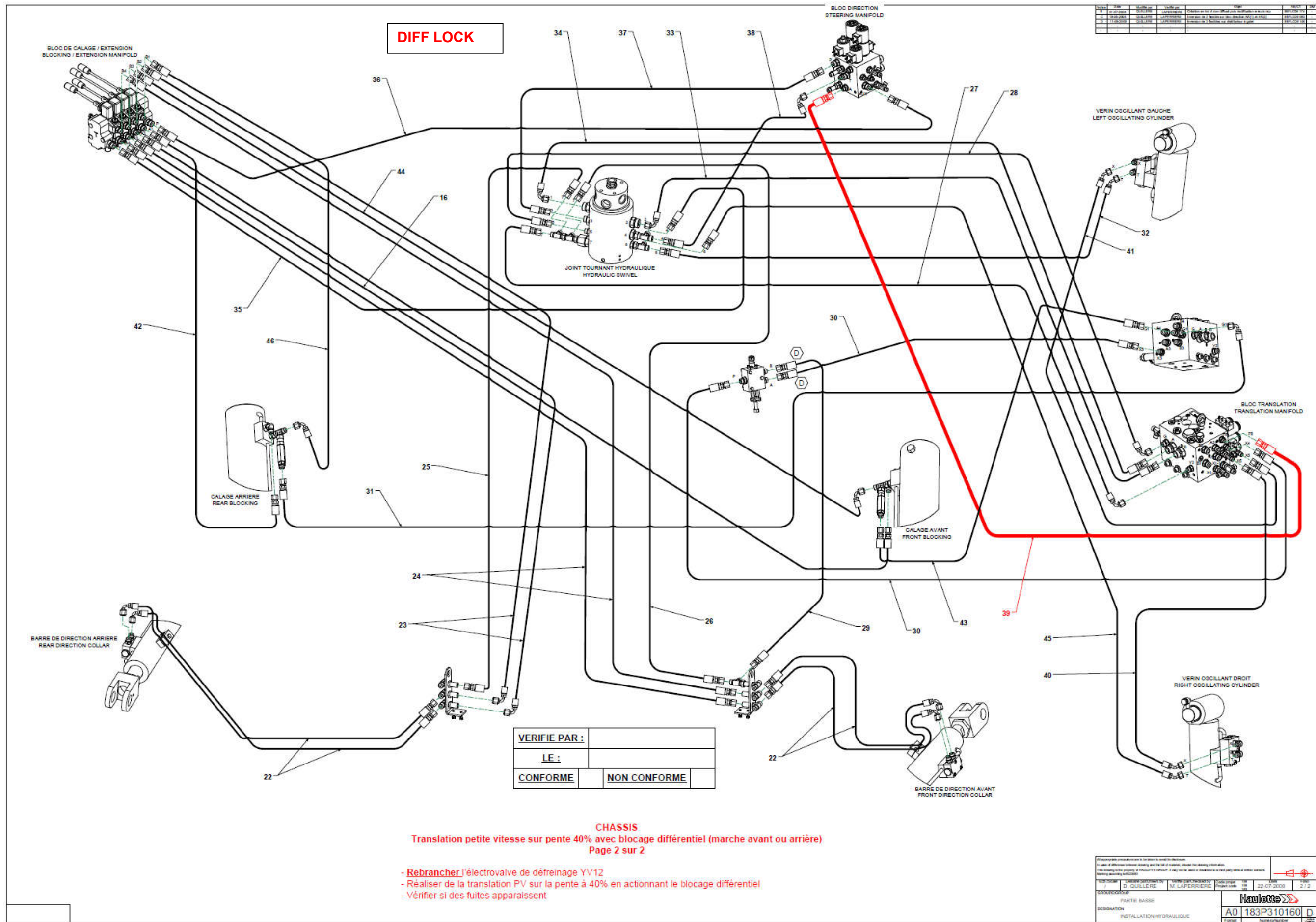



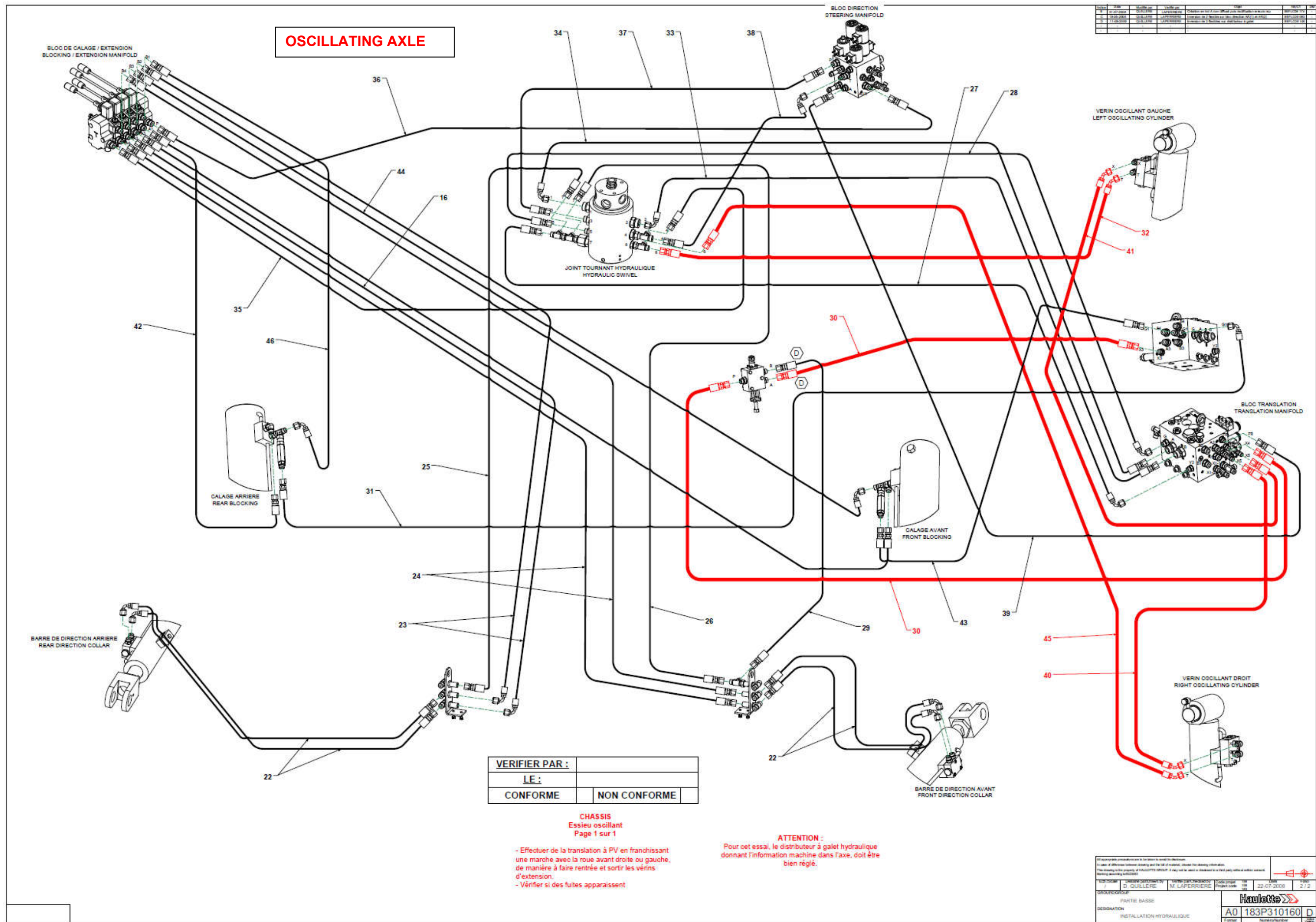

VERIFIER PAR :	
LE :	
CONFORME	NON CONFORME

CHASSIS  
Essieu oscillant  
Page 1 sur 1

- Effectuer de la translation à PV en franchissant une marche avec la roue avant droite ou gauche, de manière à faire rentrée et sortir les vérins d'extension.
- Vérifier si des fuites apparaissent.

ATTENTION :  
Pour cet essai, le distributeur à galet hydraulique donnant l'information machine dans l'axe, doit être bien réglé.

<small>All dimensions given in mm unless otherwise stated.          In case of difference between drawing and the 3D model, the 3D model shall prevail.          This drawing is the property of HAULOTTE GROUP. It may not be used or disclosed to third party without written consent.          Drawing number: A0183P310160</small>			
<small>Author:</small> <small>Checked:</small> <small>Drawn:</small>	<small>Author:</small> <small>Checked:</small> <small>Drawn:</small>	<small>Issue:</small> <small>Project code:</small>	<small>Date:</small> <small>Page:</small>
<small>GROUP/GE:</small> <small>DESIGNATION:</small>			
<small>INSTALLATION HYDRAULIQUE</small>		<b>A0 183P310160 D</b>	



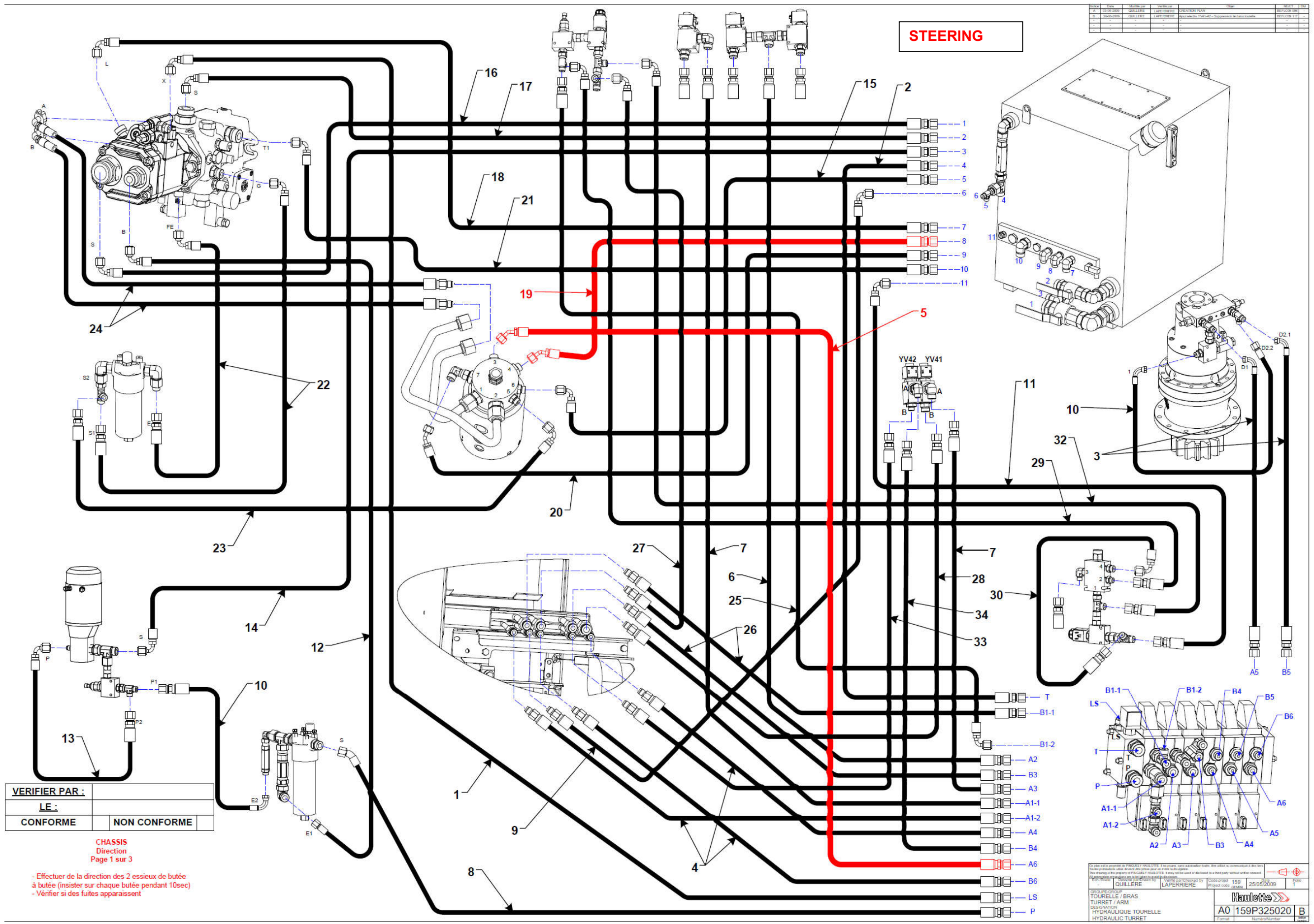

Model	Code	Model year	Control type	Directional Valve	Year	Rev
A	159P325020	2009	SOLENOID	HA41PXNT	2009	1
B	159P325020	2010	SOLENOID	HA41PXNT	2010	1

VERIFIER PAR :	
LE :	
CONFORME	NON CONFORME

CHASSIS  
Direction  
Page 1 sur 3

- Effectuer de la direction des 2 essieu de butée à butée (insister sur chaque butée pendant 10sec)
- Vérifier si des fuites apparaissent

<small>Les plans et les données de PROJET HAULOTTE, à caractère, sont réservés à la société Haulotte. Toute réimpression ou utilisation non autorisée sans la permission écrite de la société Haulotte est formellement interdite. Toute réimpression ou utilisation non autorisée sans la permission écrite de la société Haulotte est formellement interdite.</small>	
Approuvé par :	Validé par :
QUILLERE	LAPERIERE
Code projet :	159
Project code :	25/05/2009
Description : TOURELLE / BRAS TURRET / ARM OCCUPATION HYDRAULIQUE TOURELLE HYDRAULIC TURRET	
Formal	Number
A0 159P325020	B

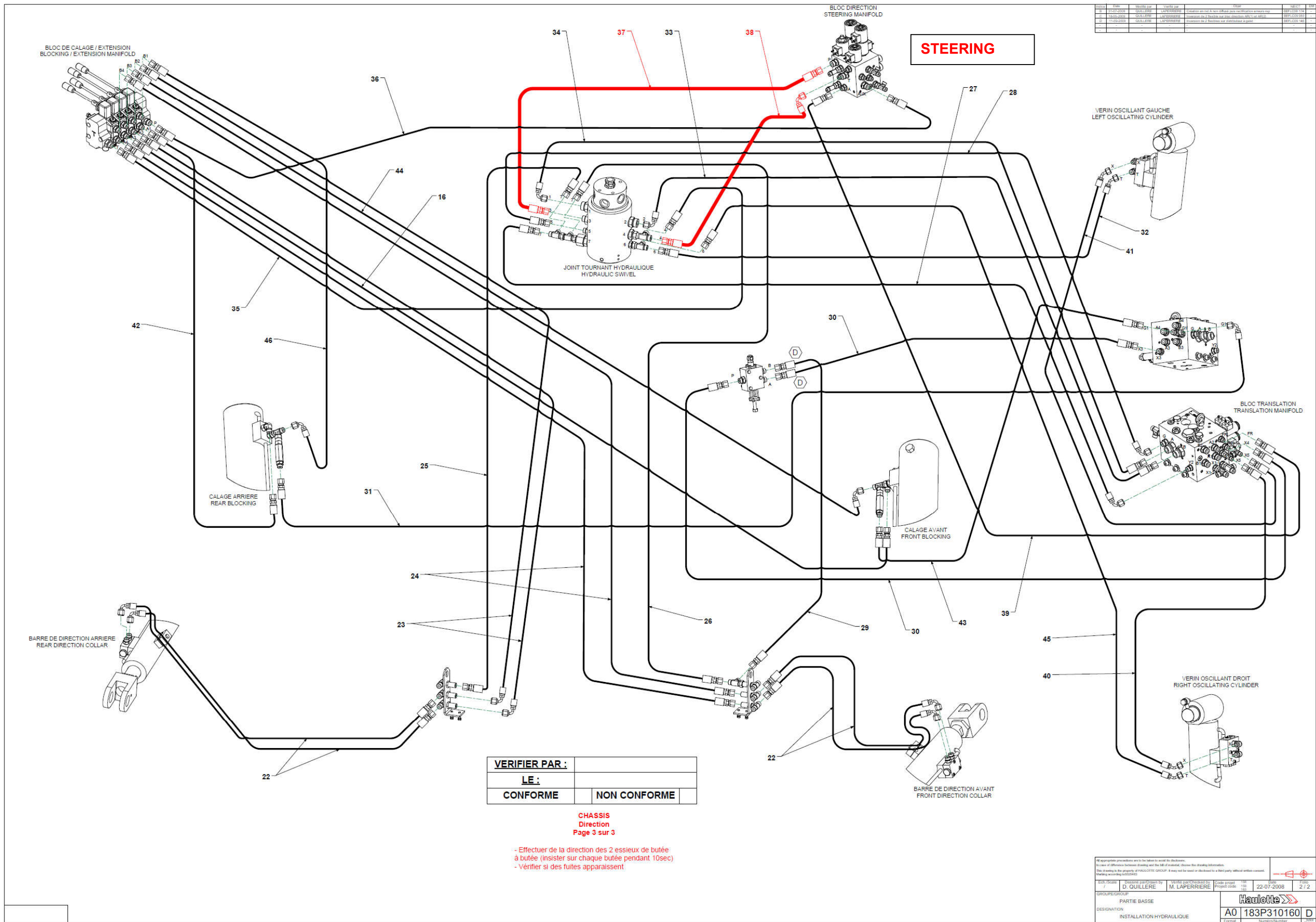

Rev.	Date	Modifié par	Verifié par	Objet	Revisé	Etat
1	17-07-2008	D. QUILLERE	M. LAPERRIERE	Installation de la barre de direction pour les véhicules à roues motrices	183P310160	1/1
2	17-08-2008	D. QUILLERE	M. LAPERRIERE	Installation de la barre de direction pour les véhicules à roues motrices	183P310160	2/1
3	17-08-2008	D. QUILLERE	M. LAPERRIERE	Installation de la barre de direction pour les véhicules à roues motrices	183P310160	3/1

<b>VERIFIER PAR :</b>	
<b>LE :</b>	
<b>CONFORME</b>	<b>NON CONFORME</b>

**CHASSIS**  
Direction  
Page 3 sur 3

- Effectuer de la direction des 2 essieux de butée à butée (insister sur chaque butée pendant 10sec)
- Vérifier si des fuites apparaissent

<small>All appropriate precautions are to be taken to avoid fire, explosion, etc.          In case of difference between drawings and the real of material, always the drawing information.          This drawing is the property of HAULOTTE GROUP. It may not be used or disclosed to a third party without written consent.          Marking according to ISO 9001</small>			
<small>DESIGNER</small> D. QUILLERE <small>GROUP/GROUP</small> PARTIE BASSE <small>DESIGNATION</small> INSTALLATION HYDRAULIQUE	<small>VERIFIÉ PAR/CHECKED BY</small> M. LAPERRIERE <small>DATE/DATE</small> 22-07-2008 <small>PROJET/PROJECT</small> 183P310160	<small>NUMERO/NUMBER</small> A0 183P310160 D <small>ETAT/STATUS</small> 2 / 2	



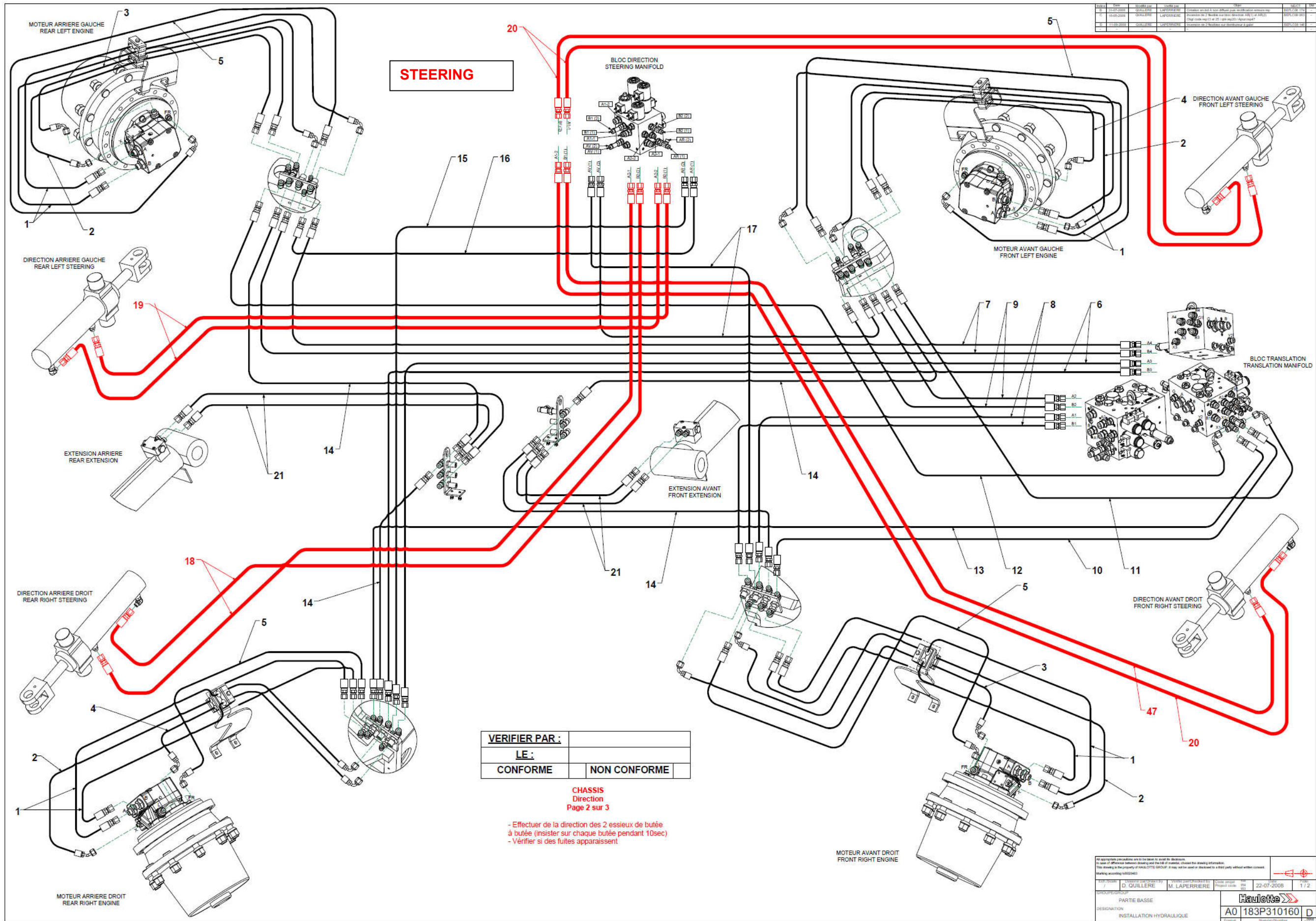

REV.	DATE	DESCRIPTION	REVISION
1	10-05-2008	QUILLERE	LAPERRIERE
2	11-05-2008	QUILLERE	LAPERRIERE

<b>VERIFIER PAR :</b>	
<b>LE :</b>	
CONFORME	NON CONFORME

**CHASSIS**  
Direction  
Page 2 sur 3

- Effectuer de la direction des 2 essieux de butée à butée (insister sur chaque butée pendant 10sec)
- Vérifier si des fuites apparaissent

All appropriate precautions are to be taken to avoid the risk of injury or death when working on hydraulic systems. This manual is the property of HAULOTTE GROUP. It may not be used or distributed to a third party without written consent. Marking according to ISO 9001.			
DESIGNER	DATE	REVISION	SCALE
D. QUILLERE	22-07-2008	1/2	
PARTIE BASSE		<b>Haulotte</b>	
DESIGNATION		A0 183P310160 D	
INSTALLATION HYDRAULIQUE			



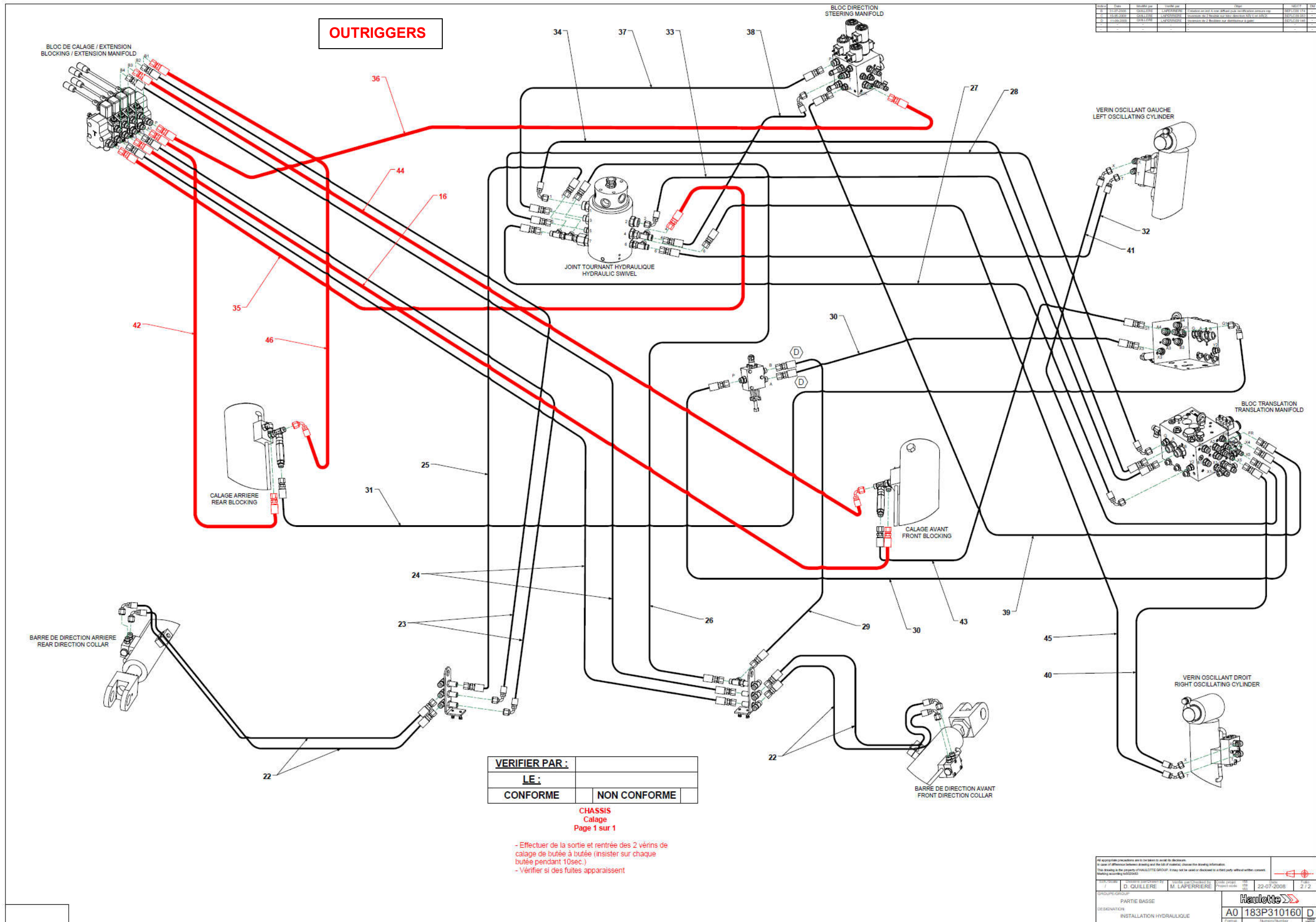

REV.	DATE	MODIF. PAR	VALIDÉ PAR	OBJET	REVISION
01	22-07-2008	D. QUILLERE	M. LAPERRIERE	Installation de la partie basse HA41PXNT/HA130JRT-NT	01/01
02	22-07-2008	D. QUILLERE	M. LAPERRIERE	Installation de la partie basse HA41PXNT/HA130JRT-NT	02/01
03	22-07-2008	D. QUILLERE	M. LAPERRIERE	Installation de la partie basse HA41PXNT/HA130JRT-NT	03/01

<b>VERIFIER PAR :</b>	
<b>LE :</b>	
CONFORME	NON CONFORME

**CHASSIS**  
Calage  
Page 1 sur 1

- Effectuer de la sortie et rentrée des 2 vérins de calage de butée à butée (insister sur chaque butée pendant 10sec.)
- Vérifier si des fuites apparaissent

<small>All appropriate precautions are to be taken to avoid fire. In case of difference between drawing and the table of material, choose the drawing information. This drawing is the property of Haulotte Group. It may not be used or disclosed to a third party without written consent. Drawing according to ISO 9001.</small>	
D. QUILLERE PARTIE BASSE INSTALLATION HYDRAULIQUE	M. LAPERRIERE 22-07-2008 2 / 2 
<b>A0 183P310160 D</b>	



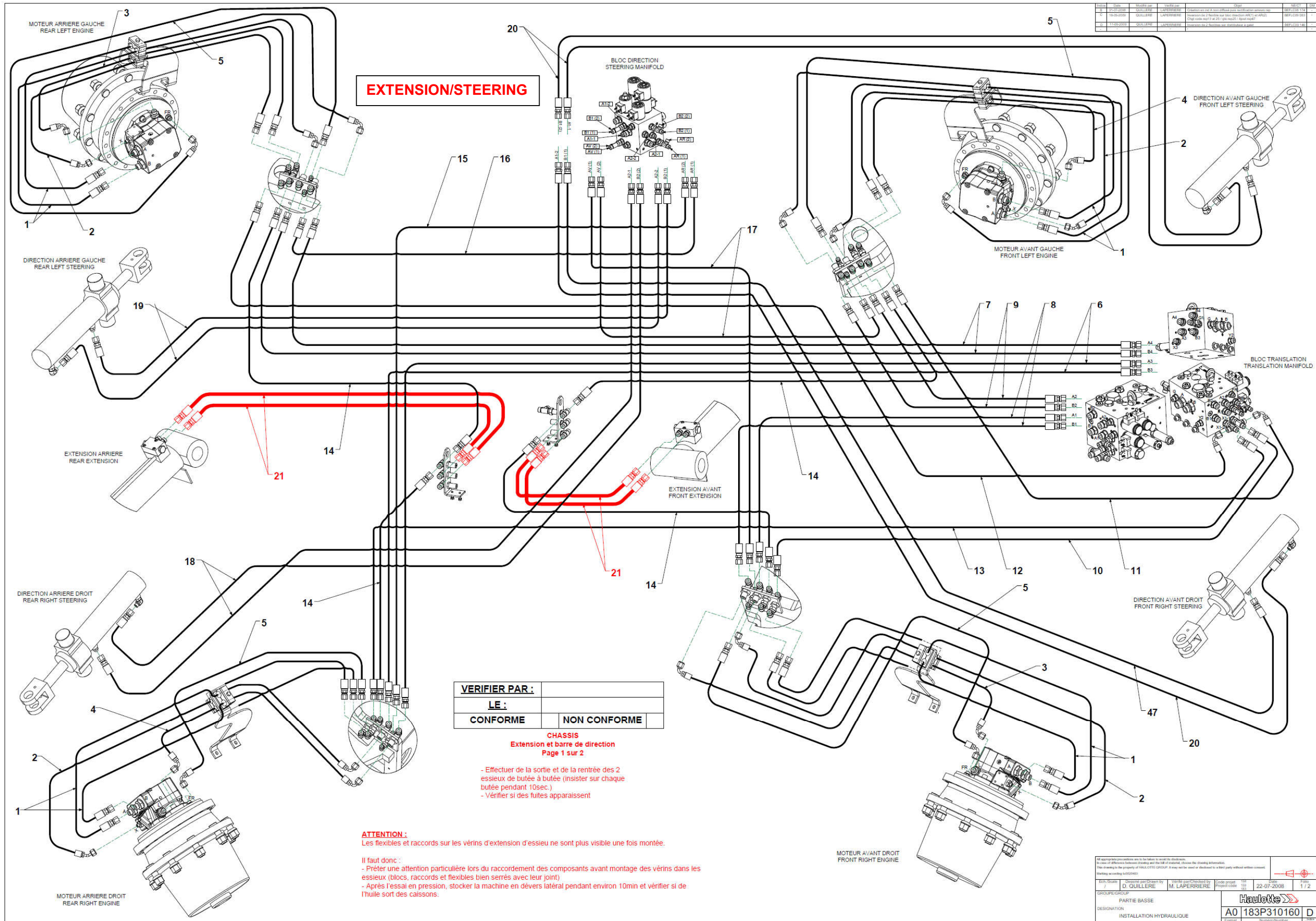

Revisé	Date	Modifié par	Validé par	Etat	REVISÉ
1	14-05-2008	QUILLERE	LAPERRIERE	Revisé en vertu de la norme ISO 9001:2008	SEP/08/134
2	14-05-2008	QUILLERE	LAPERRIERE	Revisé en vertu de la norme ISO 9001:2008	SEP/08/134
3	11-05-2009	QUILLERE	LAPERRIERE	Revisé en vertu de la norme ISO 9001:2008	SEP/09/134

All appropriate precautions are to be taken to avoid the discharge of any oil or hydraulic fluid.		Date: 22-07-2008		Page: 1/2	
Échelle: 1	Revisé en vertu de la norme ISO 9001:2008	Code groupe: 100	Projeté: 100		
GROUP/GROUP: D. QUILLERE	M. LAPERRIERE				
PARTIE BASSE		<b>Haulotte</b>			
DESIGNATION: INSTALLATION HYDRAULIQUE		A0 183P310160		D	



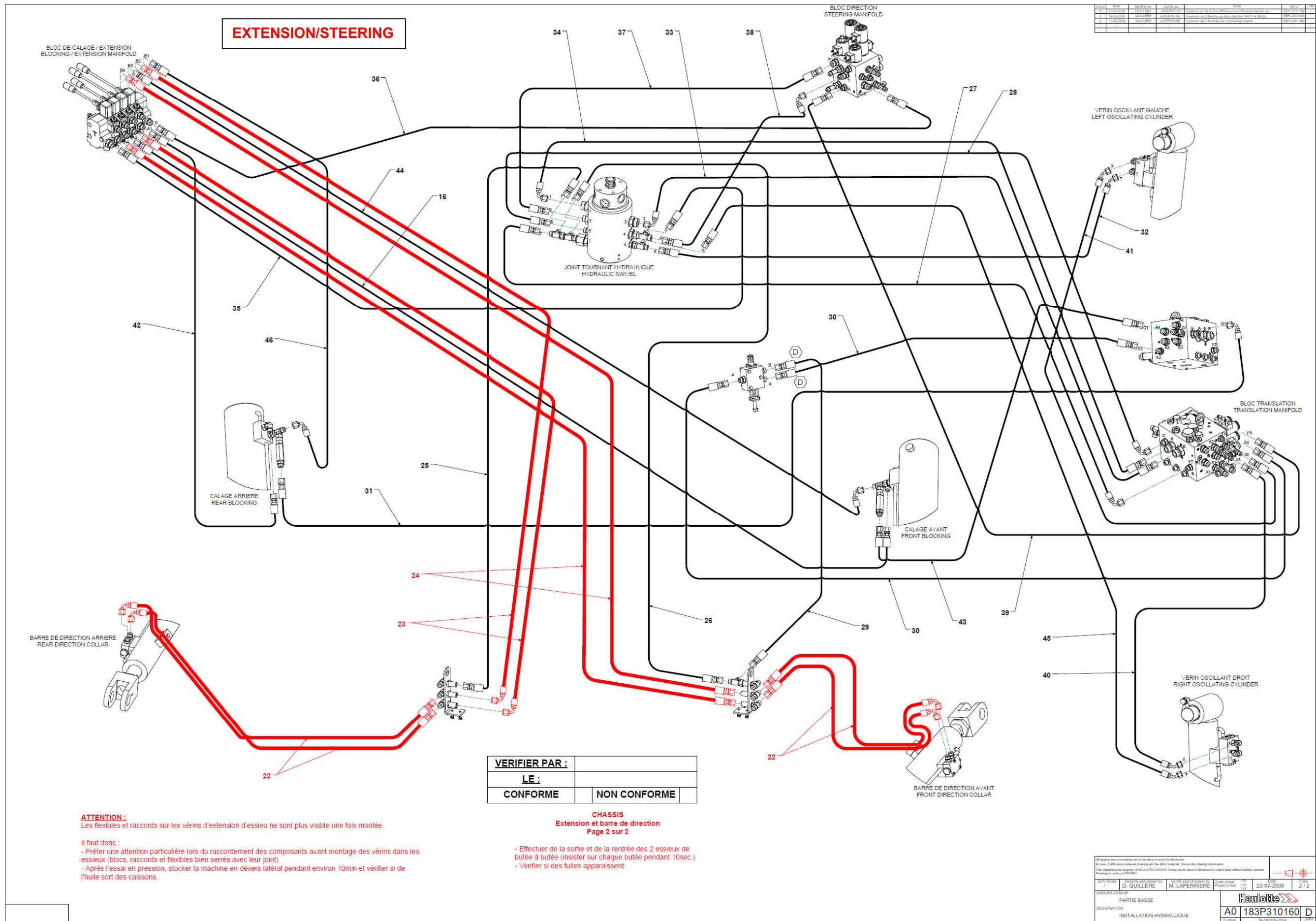

Version	Date	Modifié par	Verifié par	Objet	Page
1	17-03-2008	QUILLERE	LAPERIERRE	Installation de la barre de direction avant et arrière	2 / 2
2	17-03-2008	QUILLERE	LAPERIERRE	Installation de la barre de direction avant et arrière	2 / 2
3	17-03-2008	QUILLERE	LAPERIERRE	Installation de la barre de direction avant et arrière	2 / 2

<b>VERIFIER PAR :</b>	
<b>LE :</b>	
<b>CONFORME</b>	<b>NON CONFORME</b>

**CHASSIS**  
Extension et barre de direction  
Page 2 sur 2

- Effectuer de la sortie et de la rentrée des 2 essieux de butée à butée (insister sur chaque butée pendant 10sec.)
- Vérifier si des fuites apparaissent.

**ATTENTION :**  
Les flexibles et raccords sur les vérins d'extension d'essieu ne sont plus visible une fois montée.

- Il faut donc :
- Prêter une attention particulière lors du raccordement des composants avant montage des vérins dans les essieux (blocs, raccords et flexibles bien serrés avec leur joint)
  - Après l'essai en pression, stocker la machine en dévers latéral pendant environ 10min et vérifier si de l'huile sort des caissons.

All appropriate procedures are to be taken to avoid fire.					
In case of difference between drawings and the real of material, always the drawing information.					
This drawing is the property of HAULOTTE GROUP. It may not be used or disclosed to a third party without written consent.					
GROUPES/GRUPOU	DESIGNATION	VERIN	DATE	PROJ	Page
D. QUILLERE	M. LAPERRIERE	22-07-2008	183P310160	2 / 2	
PARTIE BASSE			<b>Haulotte</b>		
DESIGNATION			A0 183P310160 D		
INSTALLATION HYDRAULIQUE			Formel		



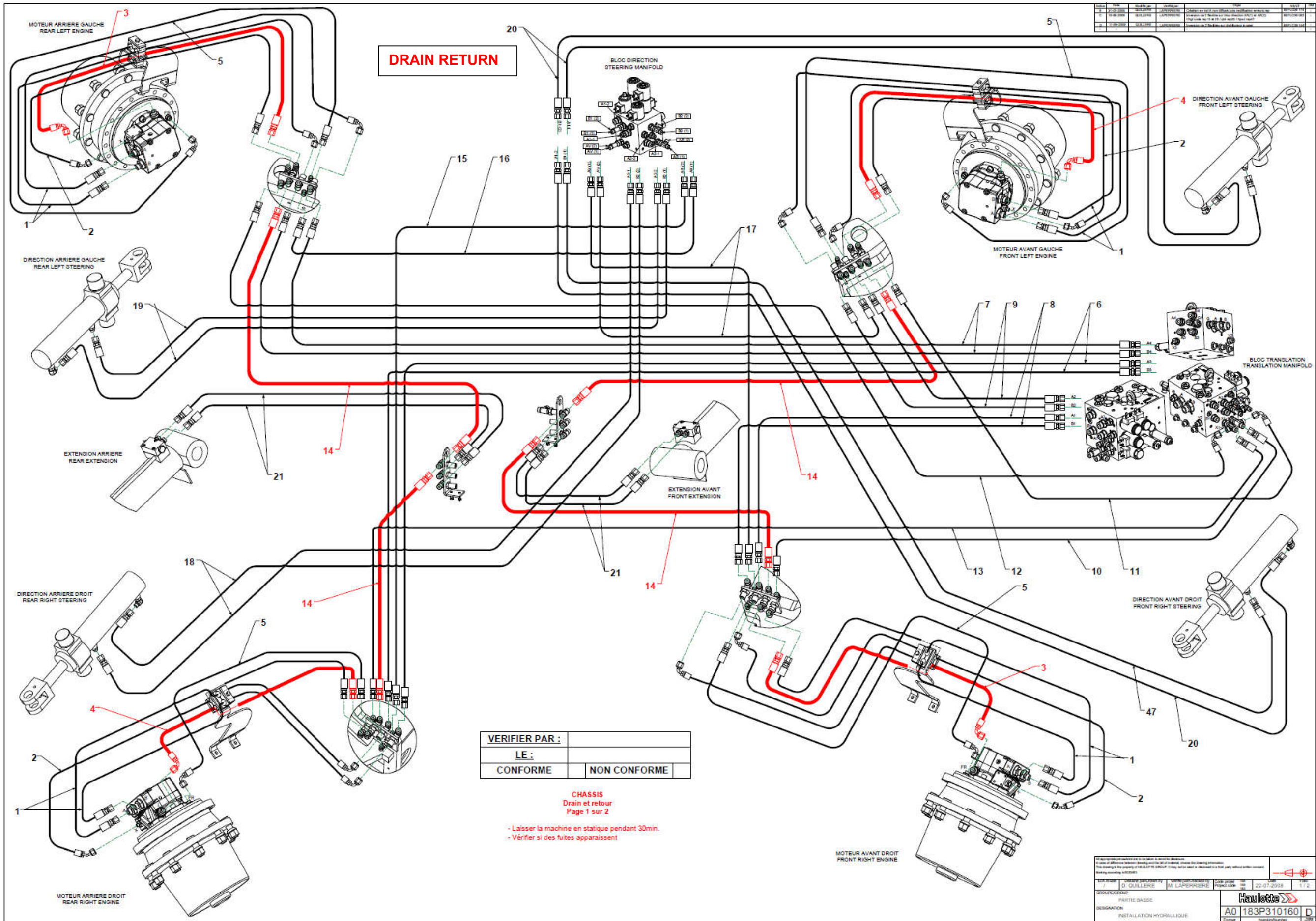

**DRAIN RETURN**

VERIFIER PAR :	
LE :	
CONFORME	NON CONFORME

**CHASSIS**  
 Drain et retour  
 Page 1 sur 2  
 - Laisser la machine en statique pendant 30min.  
 - Vérifier si des fuites apparaissent.

<small>                 All dimensions are in mm unless otherwise specified.                  All drawings are the property of HAULOTTE GROUP. They will be used in their entirety without further consent.                  Drawing number: 183P310160             </small>			
D. QUILLERE M. LAPERRIERE	22-07-2008 1/2		
DESIGNATION: INSTALLATION HYDRAULIQUE		A0 183P310160 D	



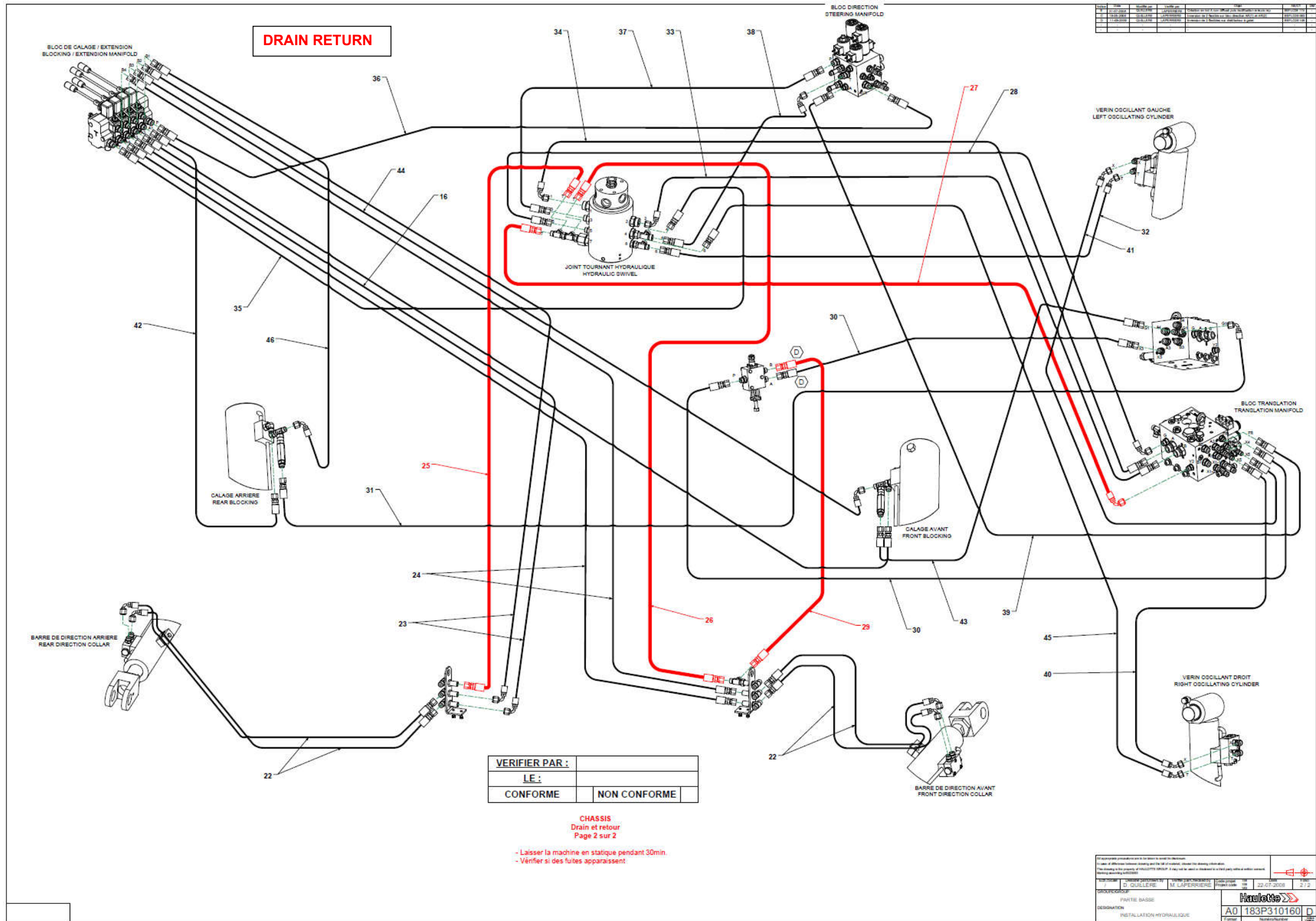



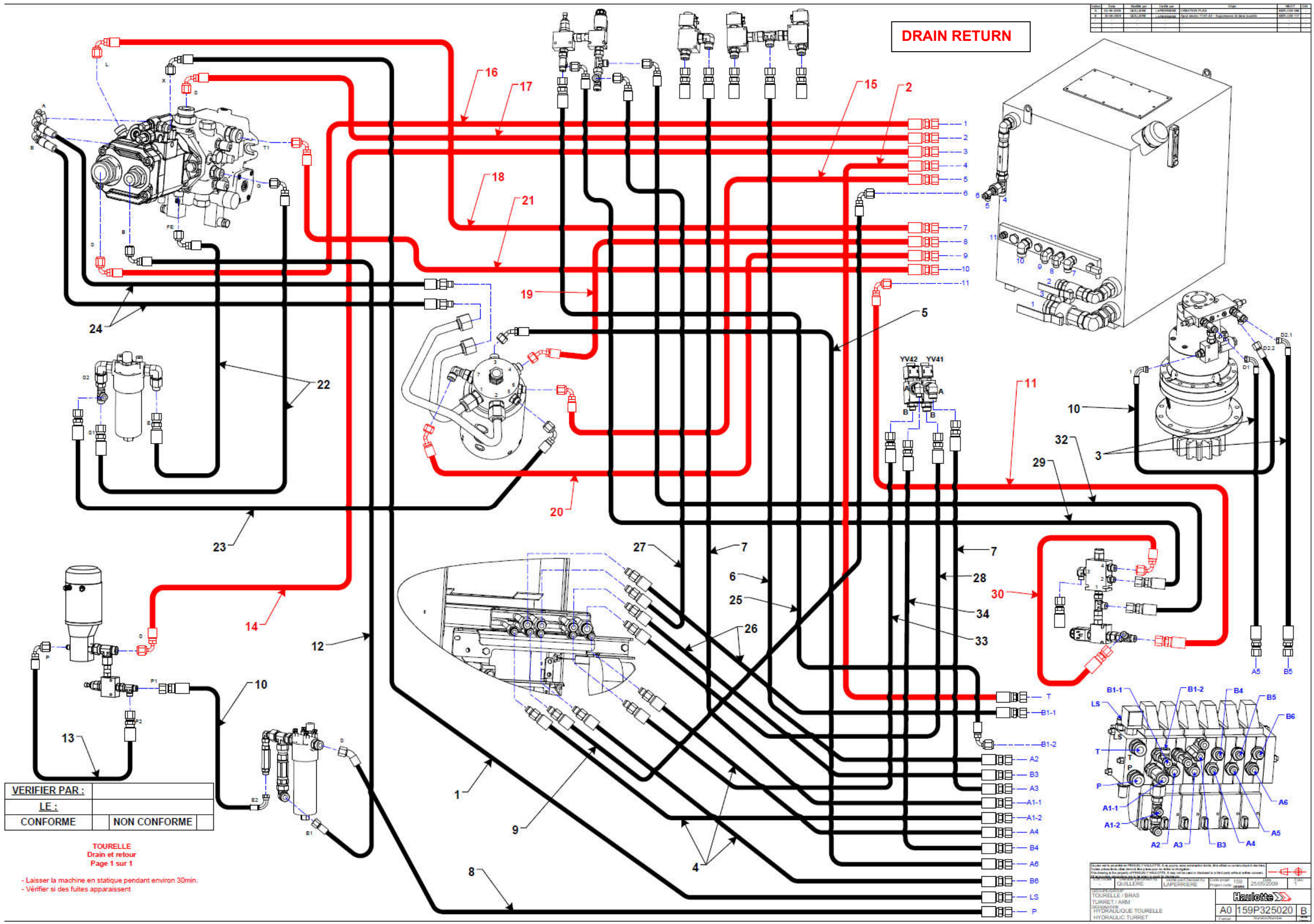

**DRAIN RETURN**

VERIFIER PAR :	
LE :	
CONFORME	NON CONFORME

TOURELLE  
Drain et retour  
Page 1 sur 1

- Laisser la machine en statique pendant environ 30min.
- Vérifier si des fuites apparaissent

Code	Date	Version	Etat	Approuvé
1	25/05/2009	1	Final	

PROJET	TOURELLE / BRAS	TOURELLE / ARM	HYDRAULIQUE TOURELLE	HYDRAULIC TURRET
QUILLERE	LAPERMIERE			
Haulotte		A0 159P325020 B		



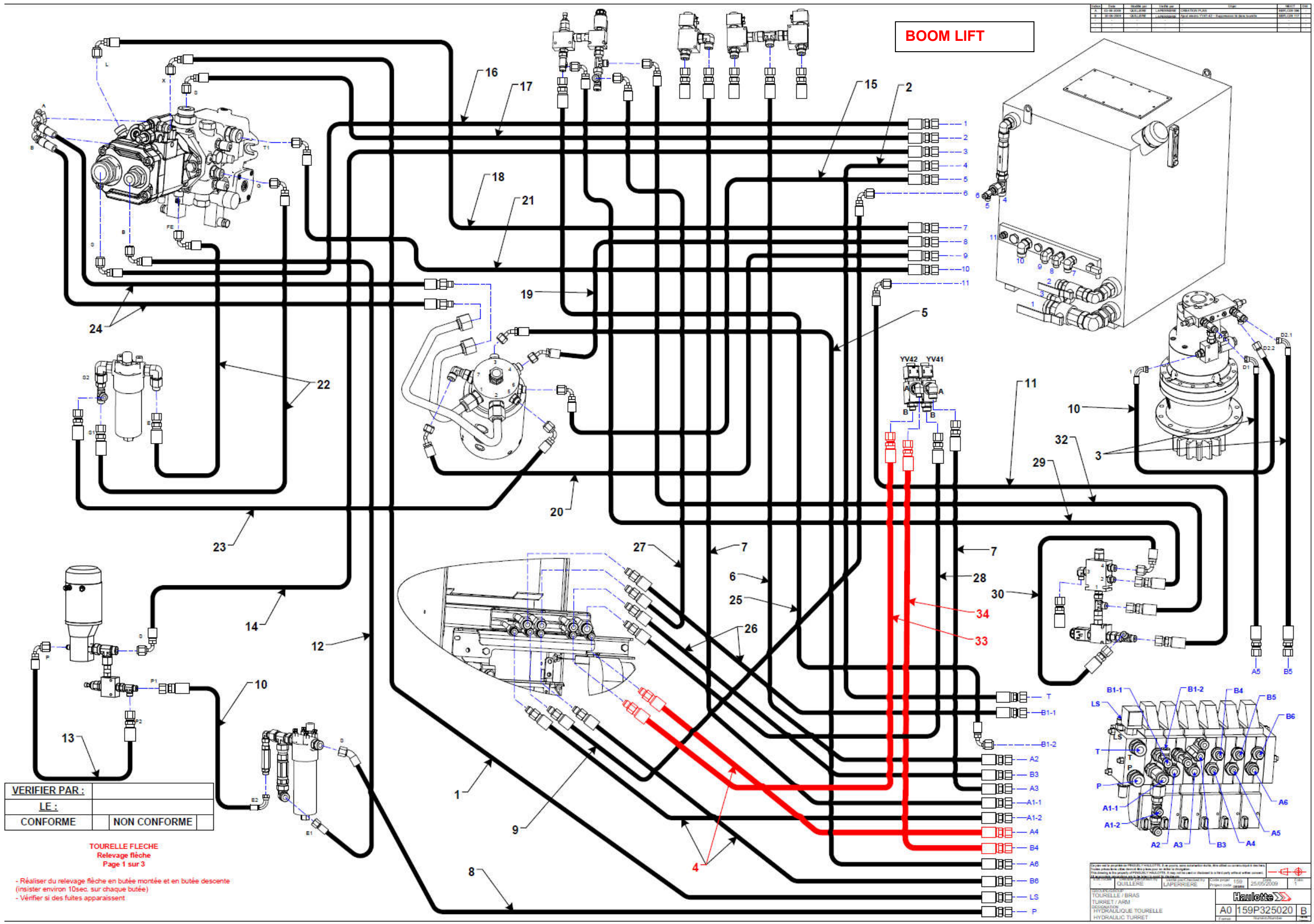

VERIFIER PAR :	
LE :	
CONFORME	NON CONFORME

**TOURELLE FLECHE**  
Relevage flèche  
Page 1 sur 3

- Réaliser du relevage flèche en butée montée et en butée descente (insister environ 10sec. sur chaque butée)
- Vérifier si des fuites apparaissent.

QUILLÈRE	LAPERMIÈRE	Code projet	159	Date	25/05/2009
TOURELLE / BRAS TURRETT / ARM RESONATOR HYDRAULIQUE TOURELLE HYDRAULIC TURRETT		<b>Haulotte</b>		A0 159P325020 B	



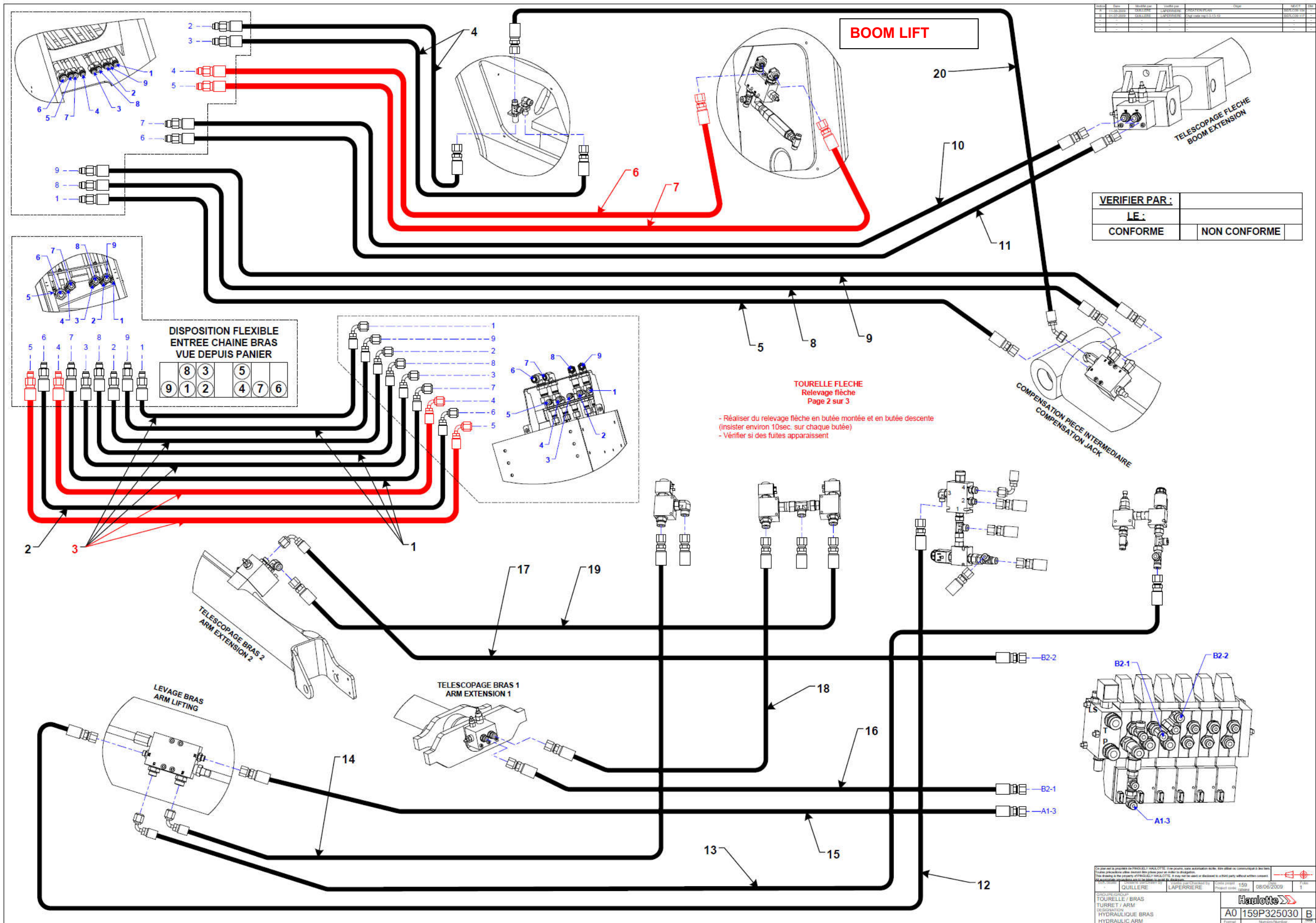

Rev.	Date	Modifié par	Validé par	Objet	REVIS
1	12/08/2009	DAVID LAFITTE	YVES BENOIST	HYDRAULIQUE	RELEVAGE FLECHE
2	12/08/2009	DAVID LAFITTE	YVES BENOIST	HYDRAULIQUE	RELEVAGE FLECHE

VERIFIER PAR :	
LE :	
CONFORME	NON CONFORME

Ce plan est la propriété de PINGULY HAULOTTE. Toute réimpression, sans autorisation écrite, est formellement interdite.					
This drawing is the property of PINGULY HAULOTTE. It may not be used or disclosed to a third party without written consent.					
QUILLERE	LAFERRIERE	150	08/06/2009	1	
TOURELLE / BRAS TURRET / ARM DESIGNATION HYDRAULIQUE BRAS HYDRAULIC ARM					
A0 159P325030			B		

REV. 01	01/01/2009	01/01/2009	01/01/2009	01/01/2009	01/01/2009	01/01/2009	01/01/2009	01/01/2009	01/01/2009
01	01	01	01	01	01	01	01	01	01

**BOOM LIFT**

<b>VERIFIER PAR :</b>	
<b>LE :</b>	
<b>CONFORME</b>	<b>NON CONFORME</b>

**TOURELLE FLECHE**  
Relevage flèche  
Page 3 sur 3

- Réaliser du relevage flèche en butée montée et en butée descente (insister environ 10sec. sur chaque butée)
- Vérifier si des fuites apparaissent

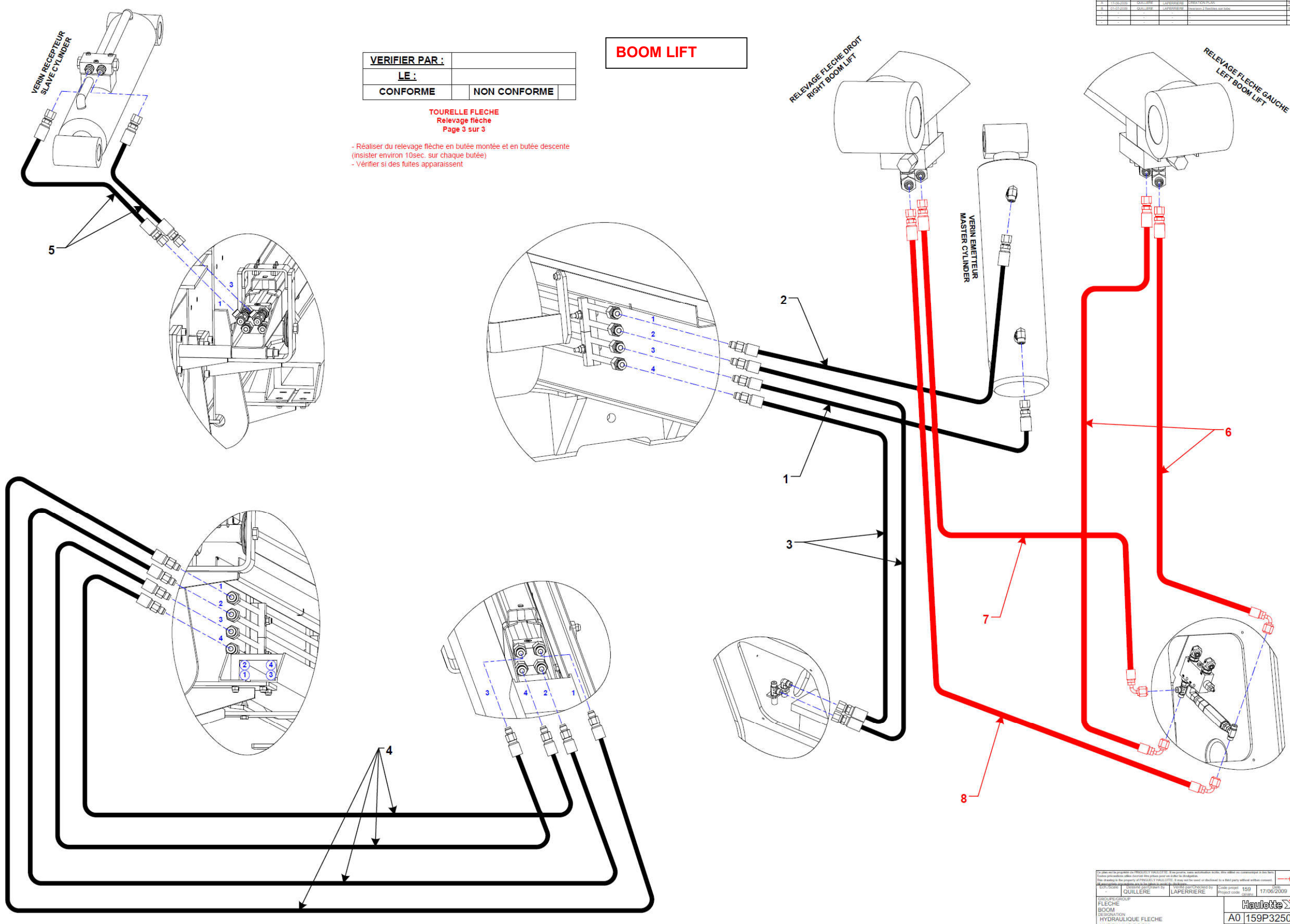

<small>Les données techniques sont données sans garantie de leur exactitude. Toute utilisation non autorisée sans la permission écrite de la Haulotte est formellement interdite. Toute réimpression ou utilisation non autorisée sans la permission écrite de la Haulotte est formellement interdite. Toute réimpression ou utilisation non autorisée sans la permission écrite de la Haulotte est formellement interdite.</small>	
<small>QUILLERE</small> <small>LAPERRIERE</small>	<small>159</small> <small>17/06/2009</small>
<b>FLECHE</b> <b>BOOM</b> <small>HYDRAULIQUE FLECHE</small> <small>HYDRAULIC BOOM</small>	
<small>A0</small>	<small>159P325050</small>



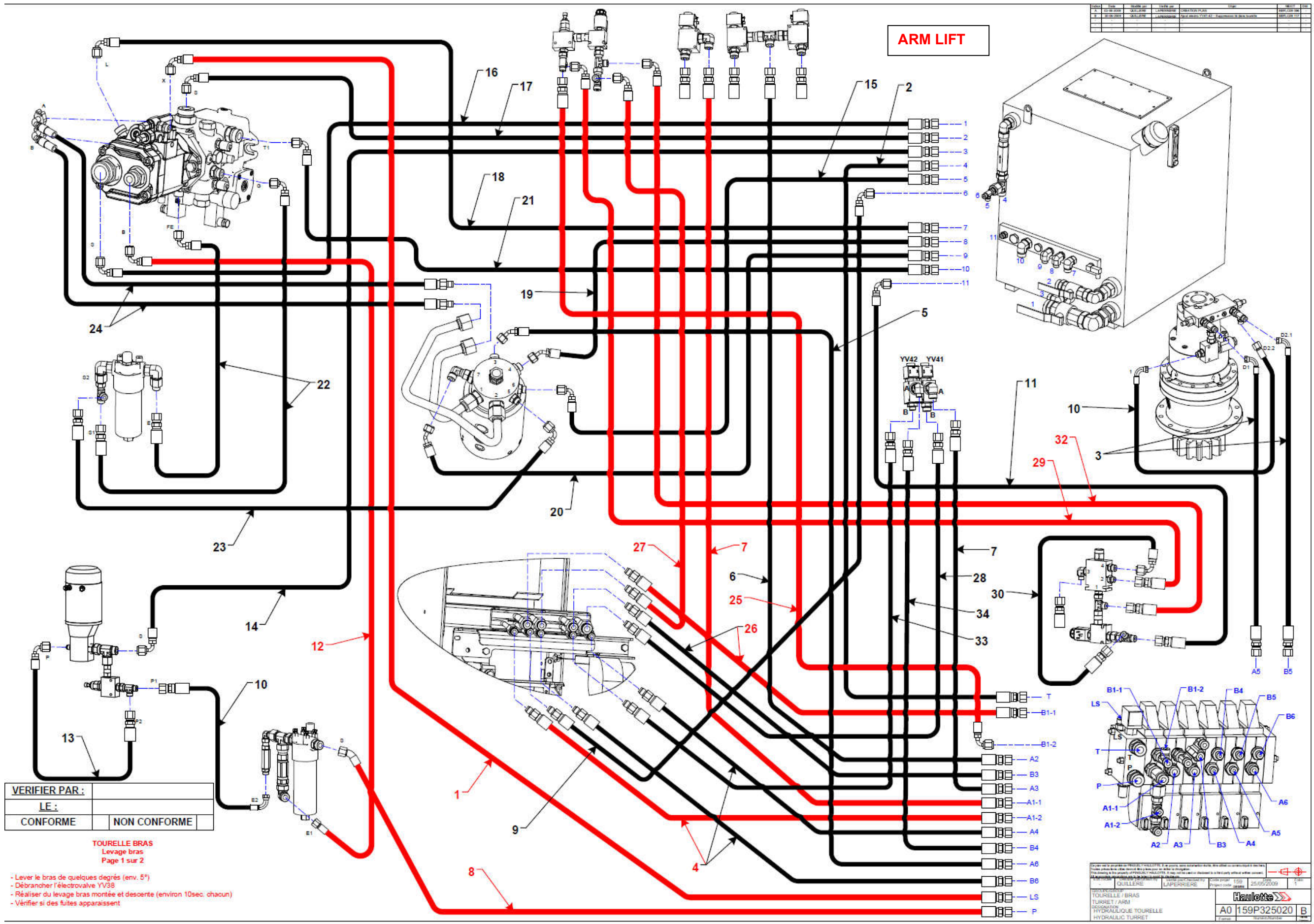

VERIFIER PAR :	
LE :	
CONFORME	NON CONFORME

TOURELLE BRAS  
Levage bras  
Page 1 sur 2

- Lever le bras de quelques degrés (env. 5°)
- Débrancher l'électrovalve YV38
- Réaliser du levage bras montée et descente (environ 10sec. chacun)
- Vérifier si des fuites apparaissent

TOURELLE / BRAS TURRET / ARM REISSTRIK / ARMO HYDRAULIQUE TOURELLE HYDRAULIC TURRET		Haulotte	
A0 159P325020		B	



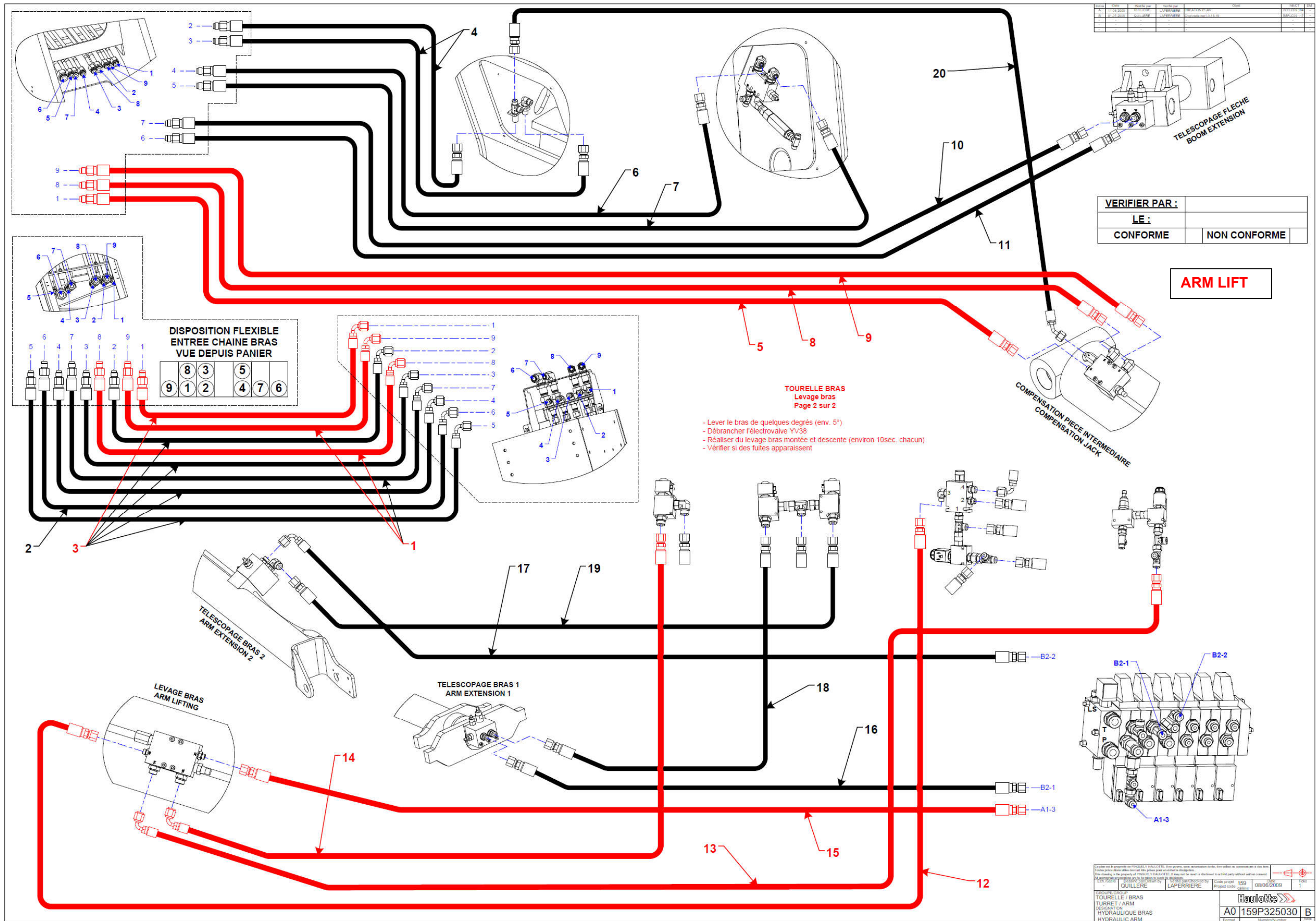

LIBR. VENTE	QUILLERE	VALVEE	159	08/06/2009	1
LIBR. VENTE	LAPERRIERE	PROJET	159	08/06/2009	1
GROUPE CLIENT TOURELLE / BRAS TURRET / ARM DELEVAGE HYDRAULIQUE BRAS HYDRAULIC ARM			Haulotte A0 159P325030 B		



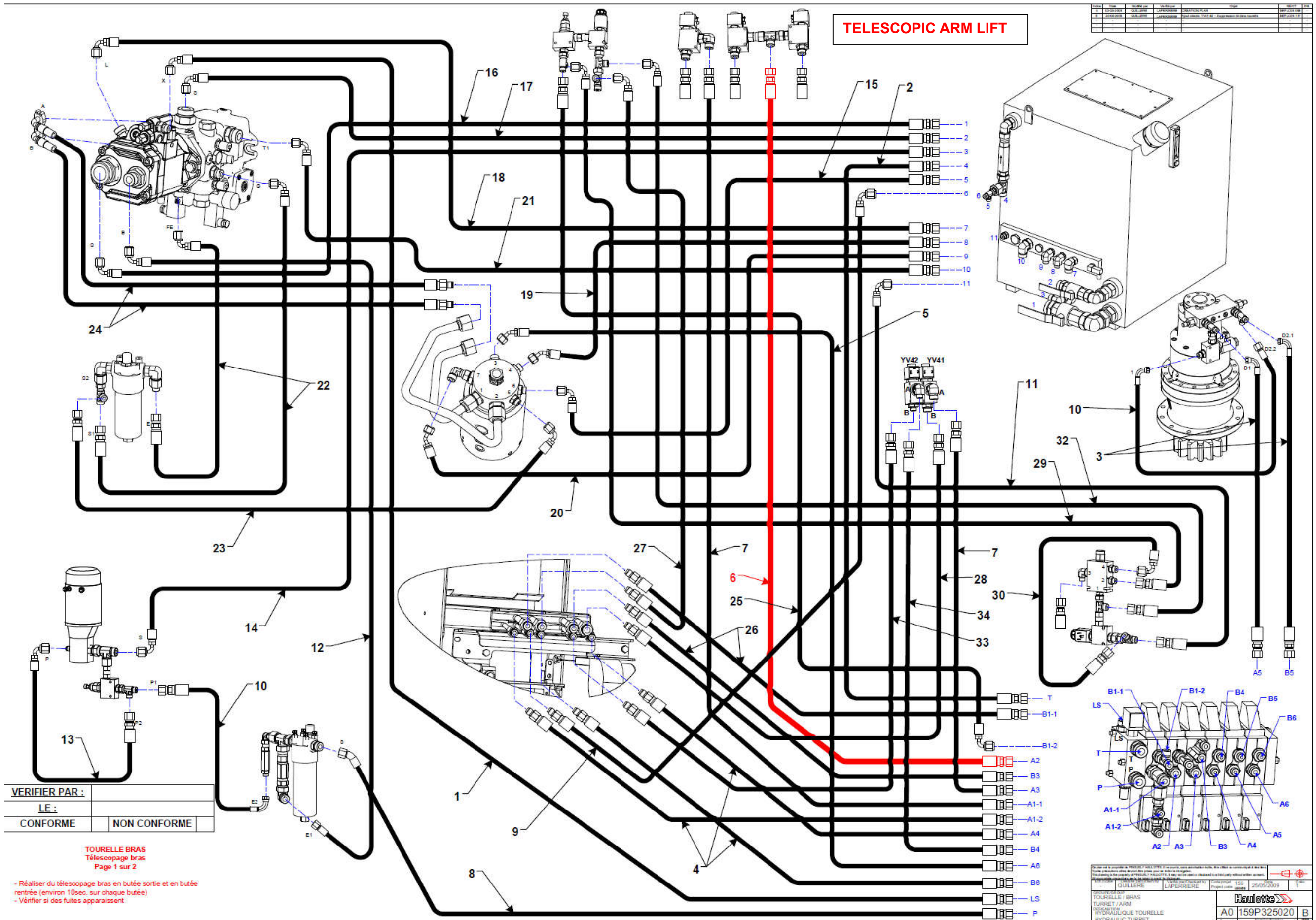



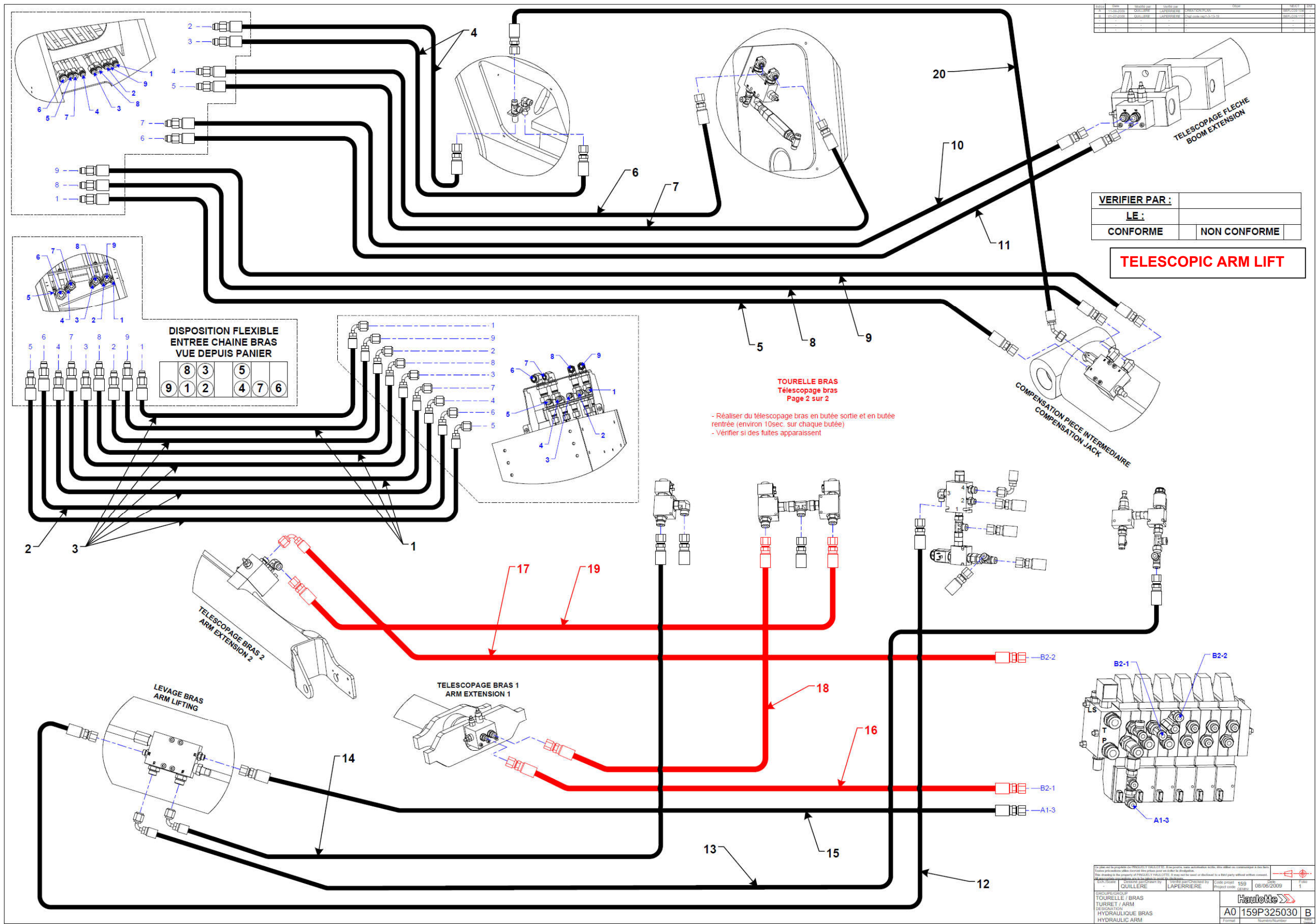

VERIFIER PAR :	
LE :	
CONFORME	NON CONFORME

**TELESCOPIC ARM LIFT**

**TOURELLE BRAS**  
Télescage bras  
Page 2 sur 2

- Réaliser du télescage bras en butée sortie et en butée rentrée (environ 10sec. sur chaque butée)
- Vérifier si des fuites apparaissent

DISPOSITION FLEXIBLE  
ENTREE CHAINE BRAS  
VUE DEPUIS PANIER

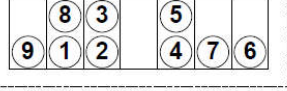

TOURELLE / BRAS TURRET / ARM HYDRAULIQUE BRAS HYDRAULIC ARM		Quilès LAPERRIERE	159 08/06/2009	1
A0 159P325030		B		



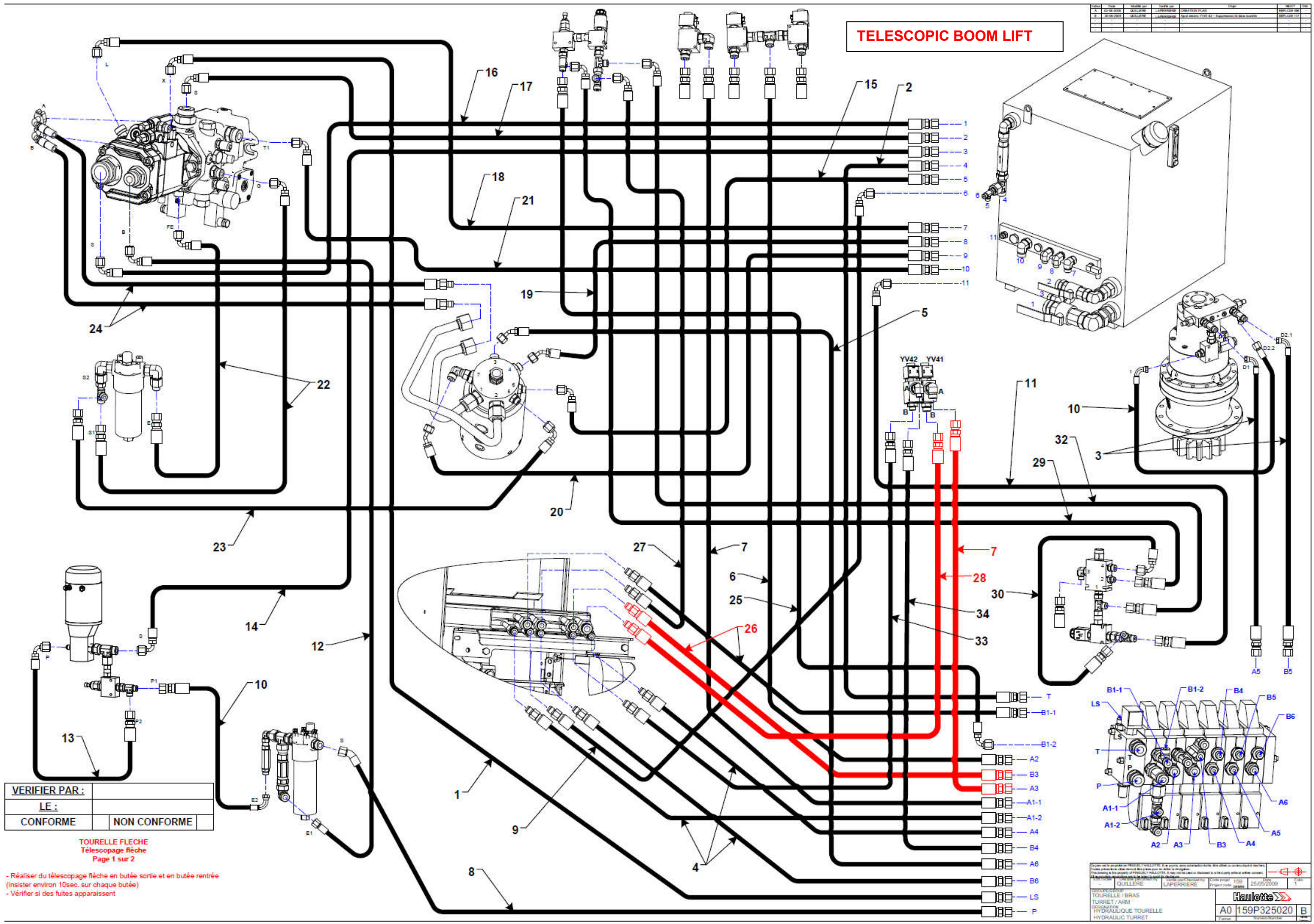



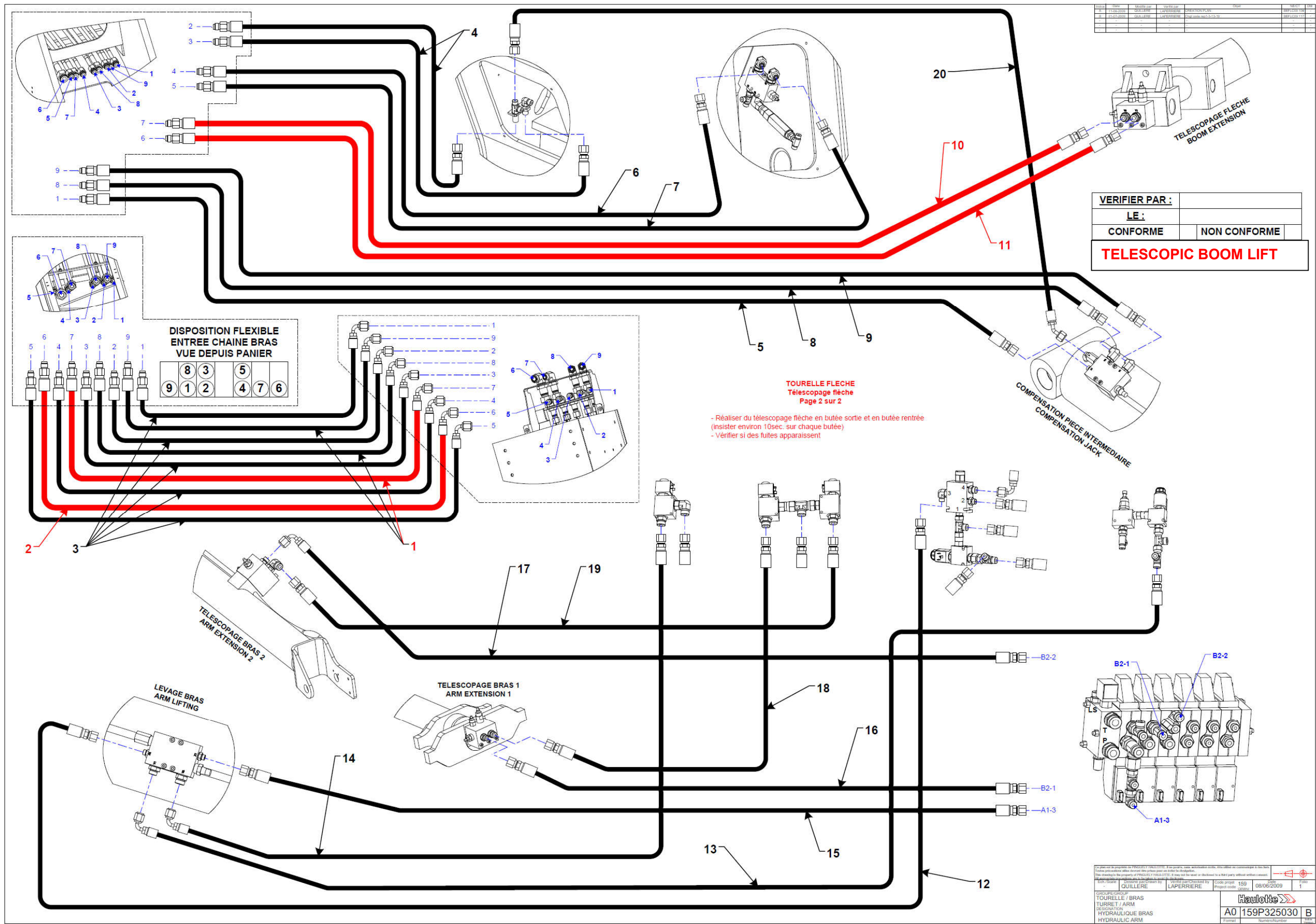

<small>© 2009 Haulotte. Tous droits réservés. Toute réimpression ou utilisation non autorisée sans la permission écrite de la Haulotte est formellement interdite. Toute reproduction ou diffusion sans autorisation préalable est formellement interdite. Toute violation sera poursuivie conformément aux lois, décrets et ordonnances en vigueur. Toute réimpression ou utilisation non autorisée sans la permission écrite de la Haulotte est formellement interdite. Toute reproduction ou diffusion sans autorisation préalable est formellement interdite. Toute violation sera poursuivie conformément aux lois, décrets et ordonnances en vigueur.</small>	
QUILLERE TOURELLE / BRAS TURRET / ARM EXTENSION HYDRAULIC BRAS HYDRAULIC ARM	LAPERRIERE 159 08/06/2009 1
A0 159P325030 B	



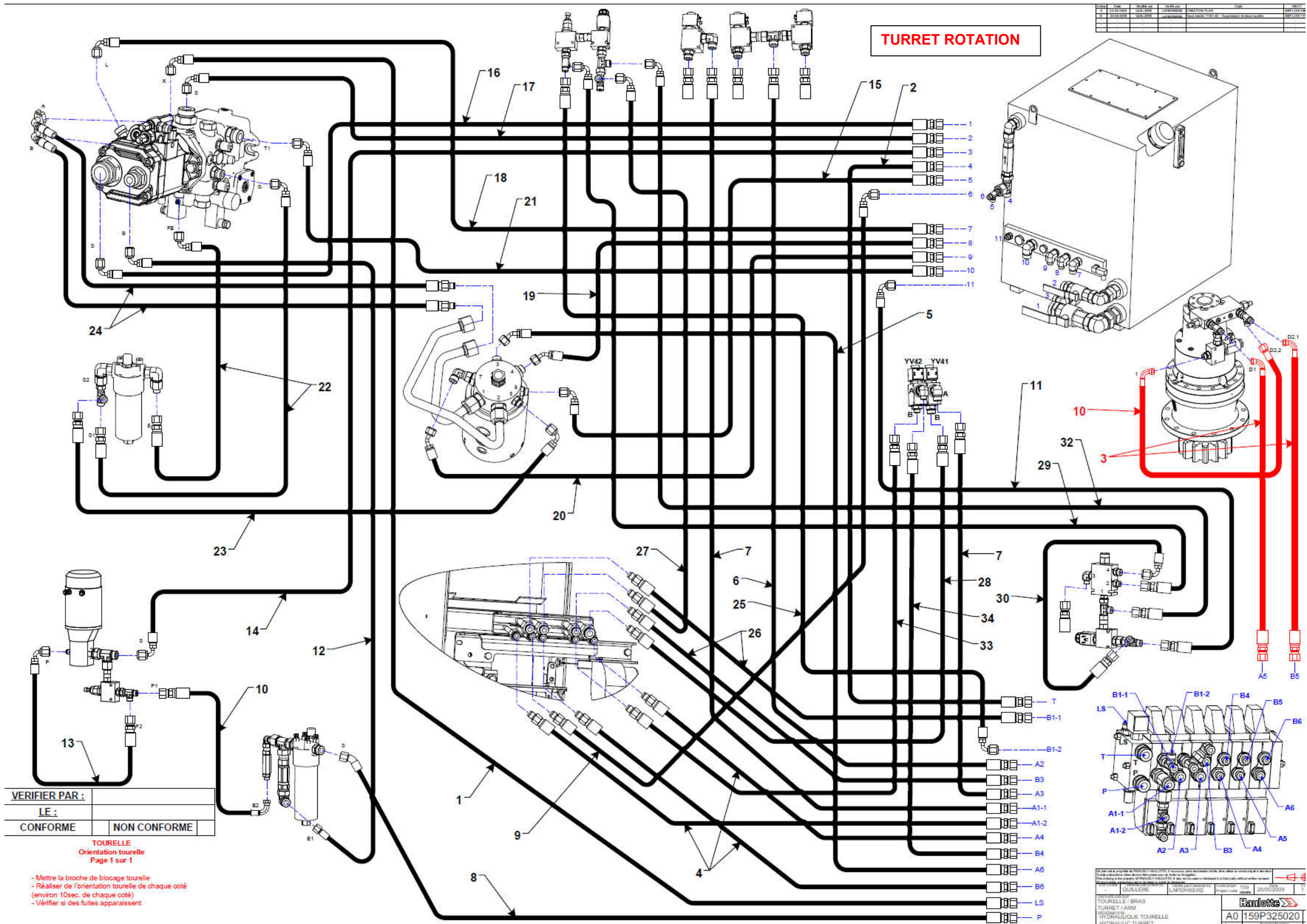

Index	Date	Modifié par	Validé par	Objet	REVIS
1	18-06-2009	LAPEYRIERE	LAPEYRIERE	HYDRAULIQUE	1

<b>VERIFIER PAR :</b>	
<b>LE :</b>	
CONFORME	NON CONFORME

**JIB**

**PENDULAIRE**  
Relevage pendulaire  
Page 1 sur 1

- Réaliser du relevage pendulaire en butée montée et en butée descente (insister environ 10sec. sur chaque butée)
- Vérifier si des fuites apparaissent

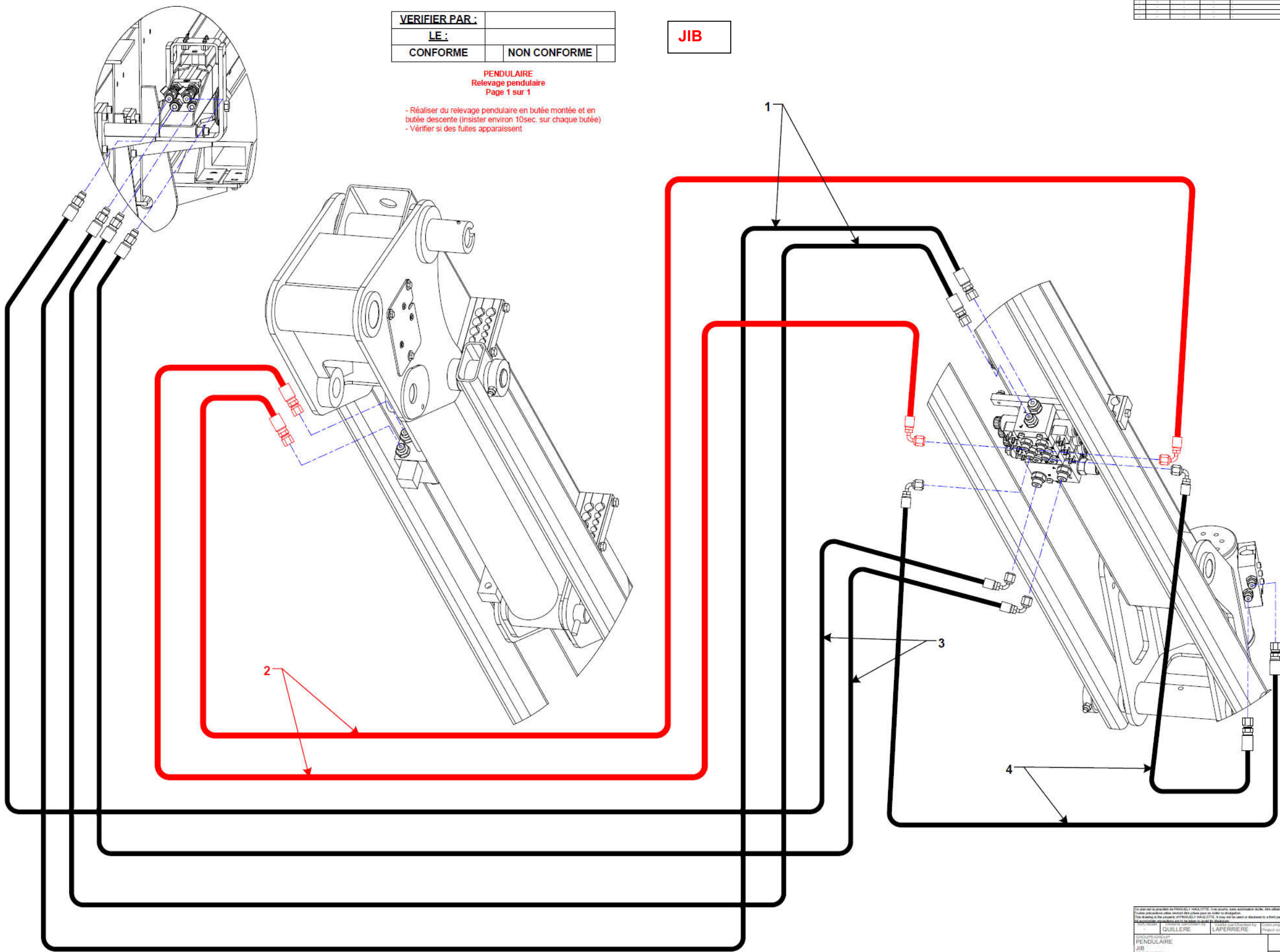

<small>On peut voir le prototype de PRODUIT HAULOTTE. C'est possible, sans autorisation écrite. En cas de litige, le client s'adresse à son fournisseur. Toute reproduction ou utilisation non autorisée sans la permission écrite de la société HAULOTTE, est formellement interdite. Toute utilisation non autorisée sera considérée comme étant illicite.</small>		
GROUPE/COMPTE PENDULAIRE JIB DESIGNATION HYDRAULIQUE PENDULAIRE HYDRAULIC JIB	QUILLERE LAPEYRIERE Date projet 15/06/2009 Version 000001	A0   159P325060   A



Index	Date	Modifié par	Validé par	Objet	REVIS
1	18-06-2009	LAPELIERE	LAPELIERE	HYDRAULIQUE	1

<b>VERIFIER PAR :</b>	
<b>LE :</b>	
CONFORME	NON CONFORME

**PENDULAIRE**  
Rotation panier  
Page 1 sur 1

- Réaliser de la rotation panier en butée droite et en butée gauche (insister environ 10sec. sur chaque butée)
- Vérifier si des fuites apparaissent

**BASKET ROTATION**

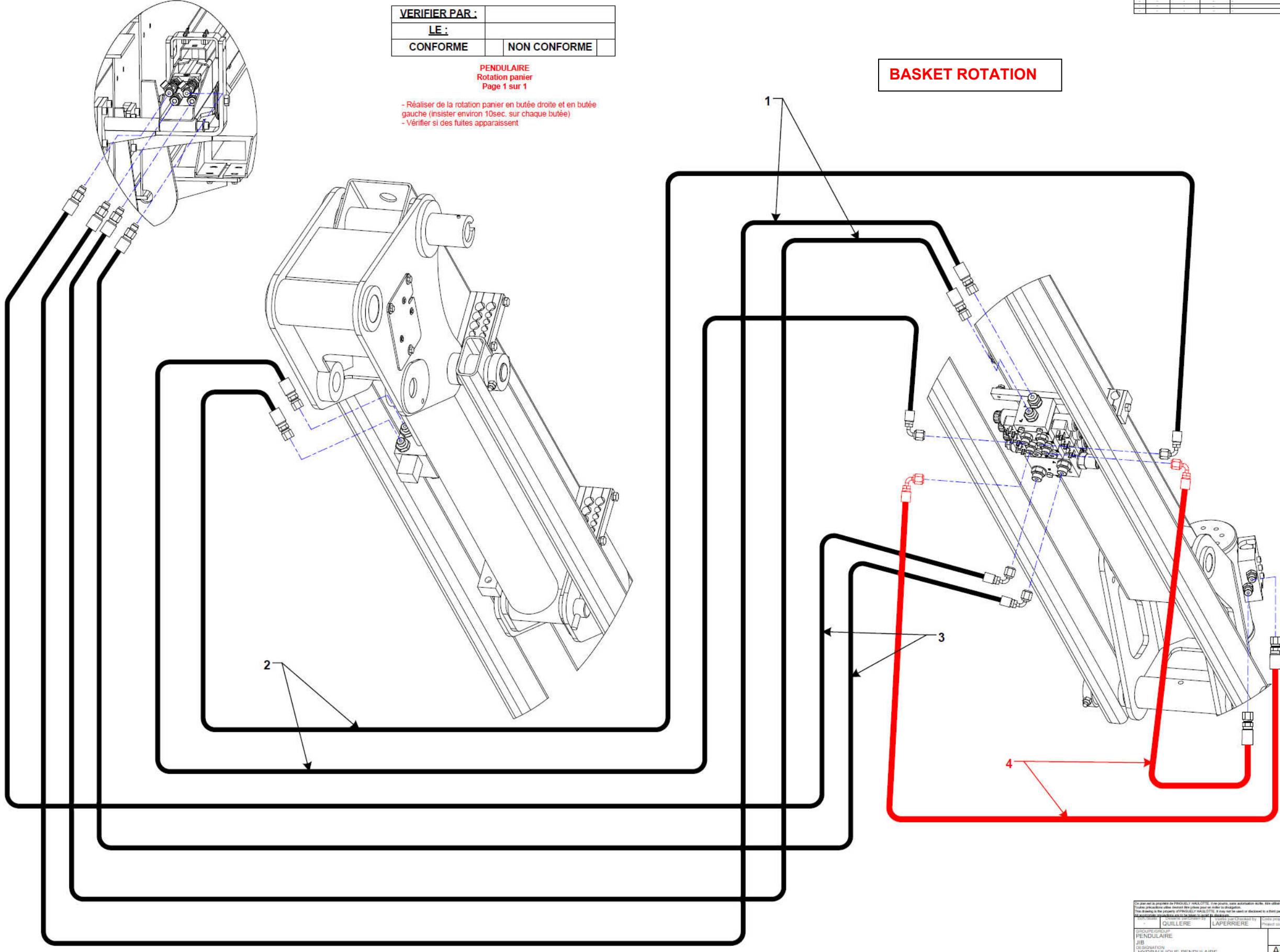

On peut voir le prototype de PROJET HAULOTTE. Ce projet, sans autorisation écrite, est strictement réservé à nos clients. Toute réimpression ou utilisation non autorisée sans la permission écrite de la société HAULOTTE, est formellement interdite. Toute utilisation non autorisée sera considérée comme une violation de nos droits.

QUILLERE	LAPELIERE	150	18/06/2009	1
				A
A0 159P325060				A



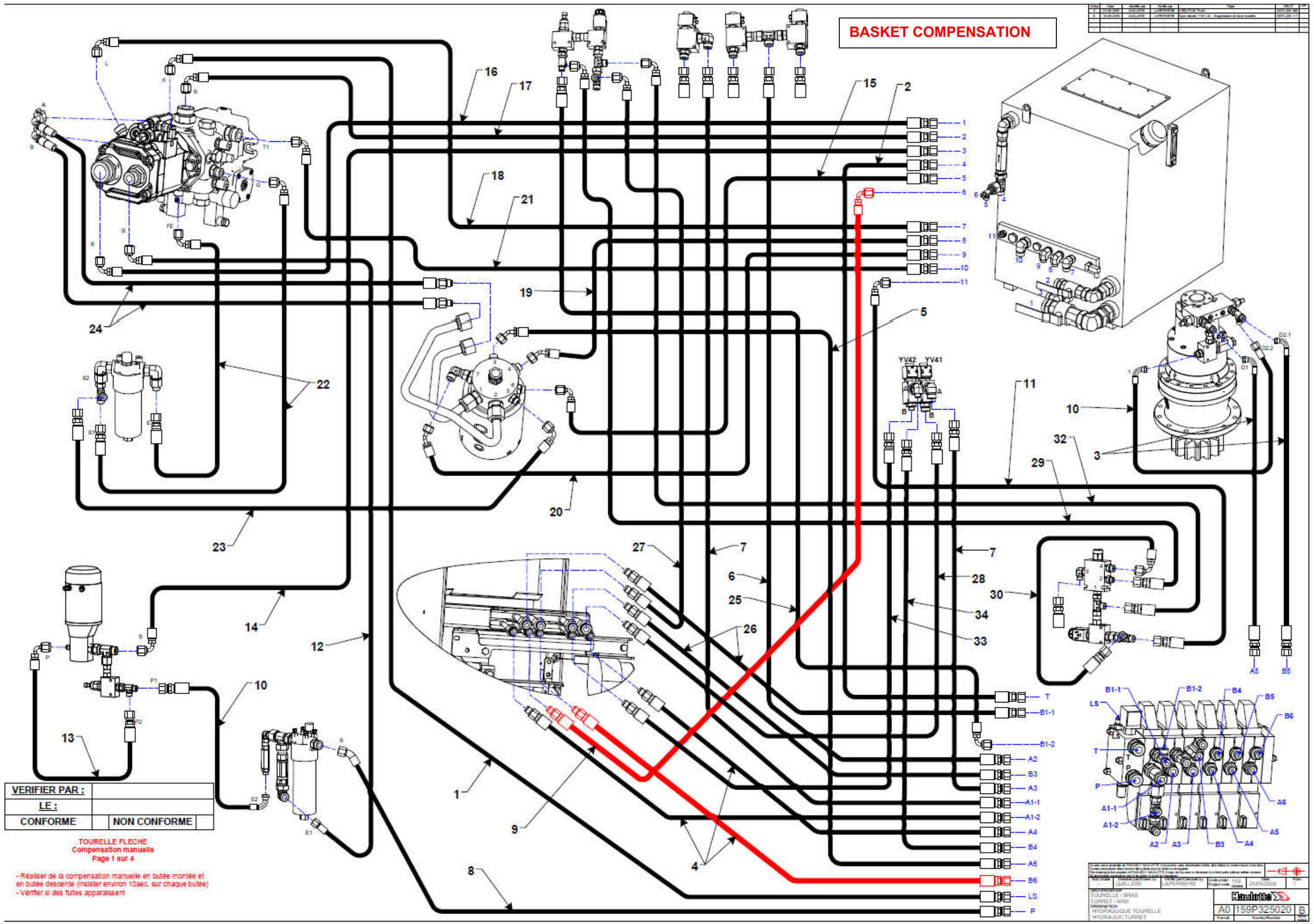

VERIFIER PAR :	
LE :	
CONFORME	NON CONFORME

**TOURELLE FLECHE**  
Compensation manuelle  
Page 1 sur 4

- Réaliser de la compensation manuelle en butée montée et en butée descendante (insister environ 10sec. sur chaque butée)
- Vérifier si des fuites apparaissent

DATE	OPERATEUR	PROBLEME	REPARATION	REMARKS

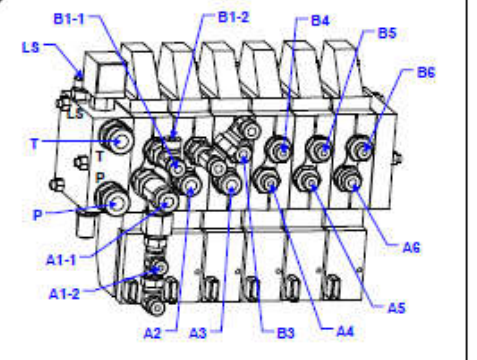

PROBLEME	REPARATION	DATE	
TOURELLE / BRAS			
TURRET / ARM			
HYDRAULIQUE TOURELLE			
HYDRAULIC TURRET			

**A0 159P325020**



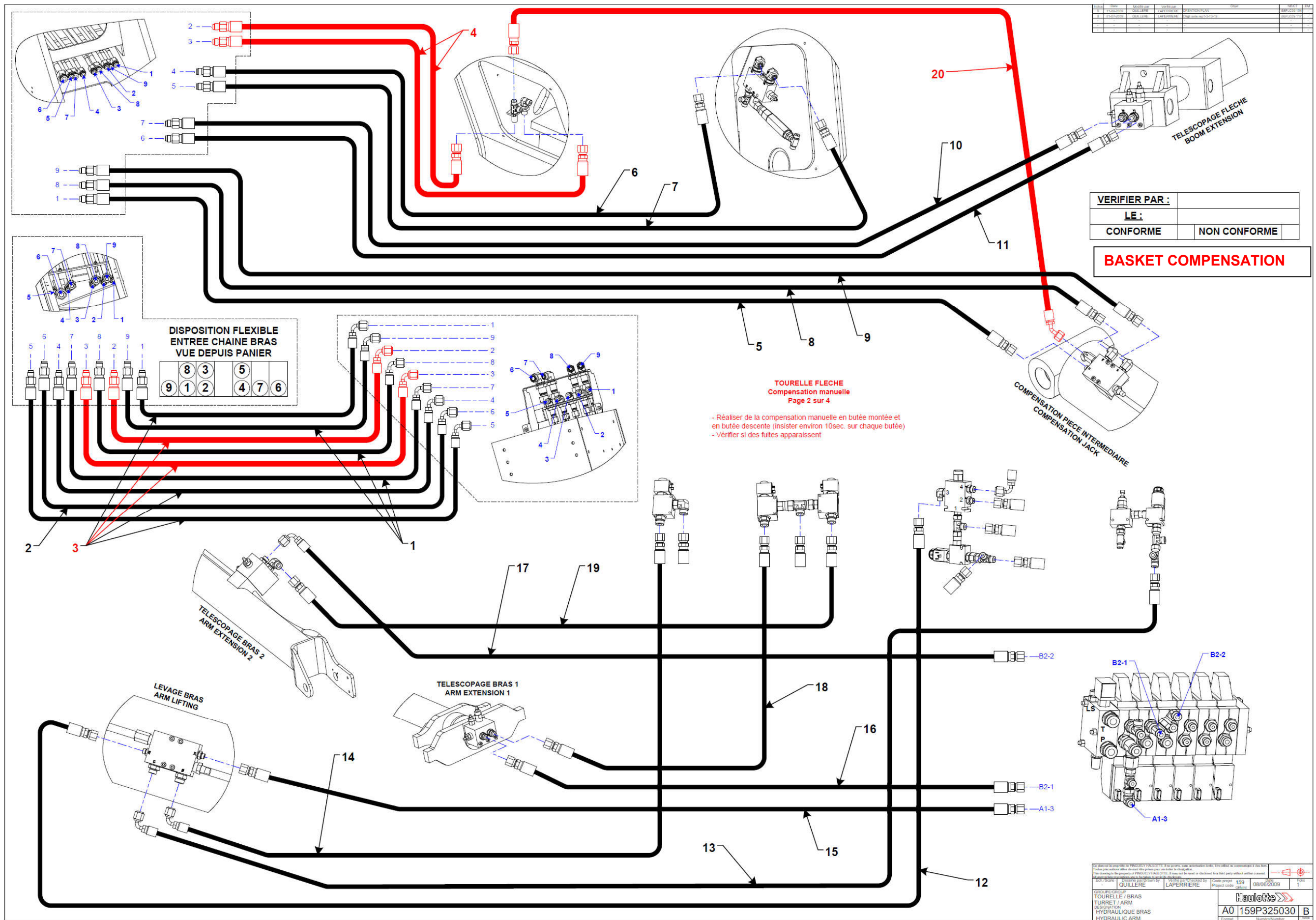

REV.	DATE	MODELE	DESCRIPTION	REVISION
1	11/08/2009	0001	LAPELIERE	0001
2	11/08/2009	0001	LAPELIERE	0002

VERIFIER PAR :	
LE :	
CONFORME	NON CONFORME

**BASKET COMPENSATION**

<small>Not allowed to reproduce or distribute this graphic, text, illustration, etc. without the authorization of the author.          Toute réimpression ou diffusion sans autorisation écrite est formellement interdite.          This drawing is the property of Haulotte. It may not be used or disclosed to a third party without written consent.          Toute réimpression ou diffusion sans autorisation écrite est formellement interdite.</small>			
QUILLERE	LAPERIERE	Code projet	08/06/2009
159			1
DISCIPLINE / GROUPE TOURILLE / BRAS TURRET / ARM SUSPENSION HYDRAULIQUE BRAS HYDRAULIC ARM		Haulotte <b>A0 159P325030</b> B	

Modèle	Date	Modifié par	Validé par	Version	Statut
HA130JRT	17/06/2009	LAPELIERE	LAPELIERE	1	VALIDÉ
HA130JRT	17/06/2009	LAPELIERE	LAPELIERE	1	VALIDÉ
HA130JRT	17/06/2009	LAPELIERE	LAPELIERE	1	VALIDÉ

**BASKET COMPENSATION**

<b>VERIFIER PAR :</b>	
<b>LE :</b>	
CONFORME	NON CONFORME

TOURELLE FLECHE  
Compensation manuelle  
Page 3 sur 4

- Réaliser de la compensation manuelle en butée montée et en butée descente (insister environ 10sec. sur chaque butée)
- Vérifier si des fuites apparaissent

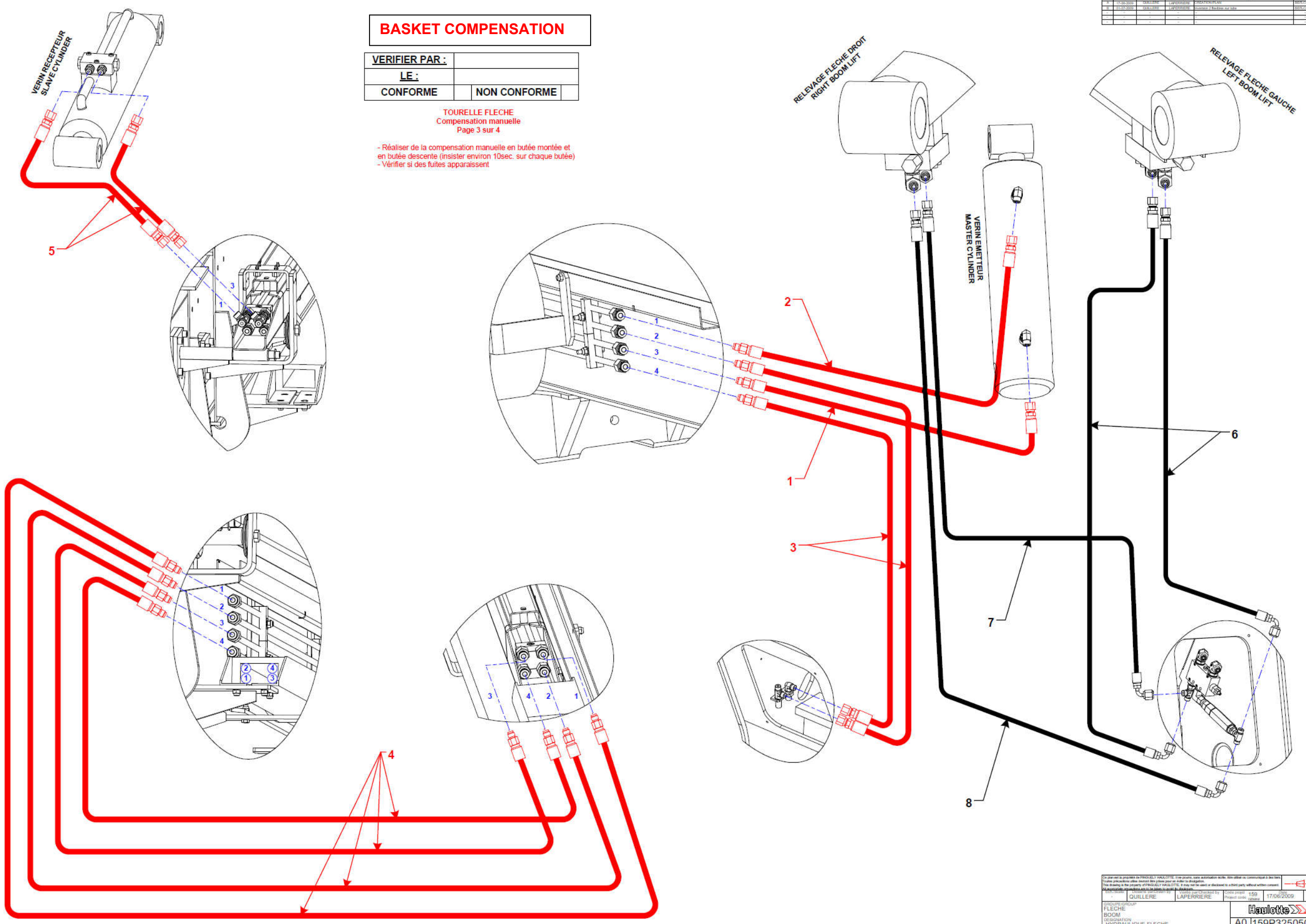

On peut voir le prototype de PROJET HAULOTTE. Ce projet, sans autorisation écrite, est strictement réservé à nos clients. Toute réimpression ou utilisation non autorisée sans la permission écrite de la Haulotte est formellement interdite. This drawing is the property of PROJET HAULOTTE. It may not be used or disclosed to a third party without written consent. Reproduction or unauthorized use without the written permission of Haulotte is strictly prohibited.

QUILLERE	LAPELIERE	150	17/06/2009	1
<b>Haulotte</b>				
A0 159P325050				B



REV.	DATE	REVISION	DESCRIPTION	APP. (Signature)

<b>VERIFIER PAR :</b>	
<b>LE :</b>	
CONFORME	NON CONFORME

**BASKET COMPENSATION**

**TOURELLE FLECHE**  
Compensation manuelle  
Page 4 sur 4

- Réaliser de la compensation manuelle en butée montée et en butée descente (insister environ 10sec. sur chaque butée)
- Vérifier si des fuites apparaissent

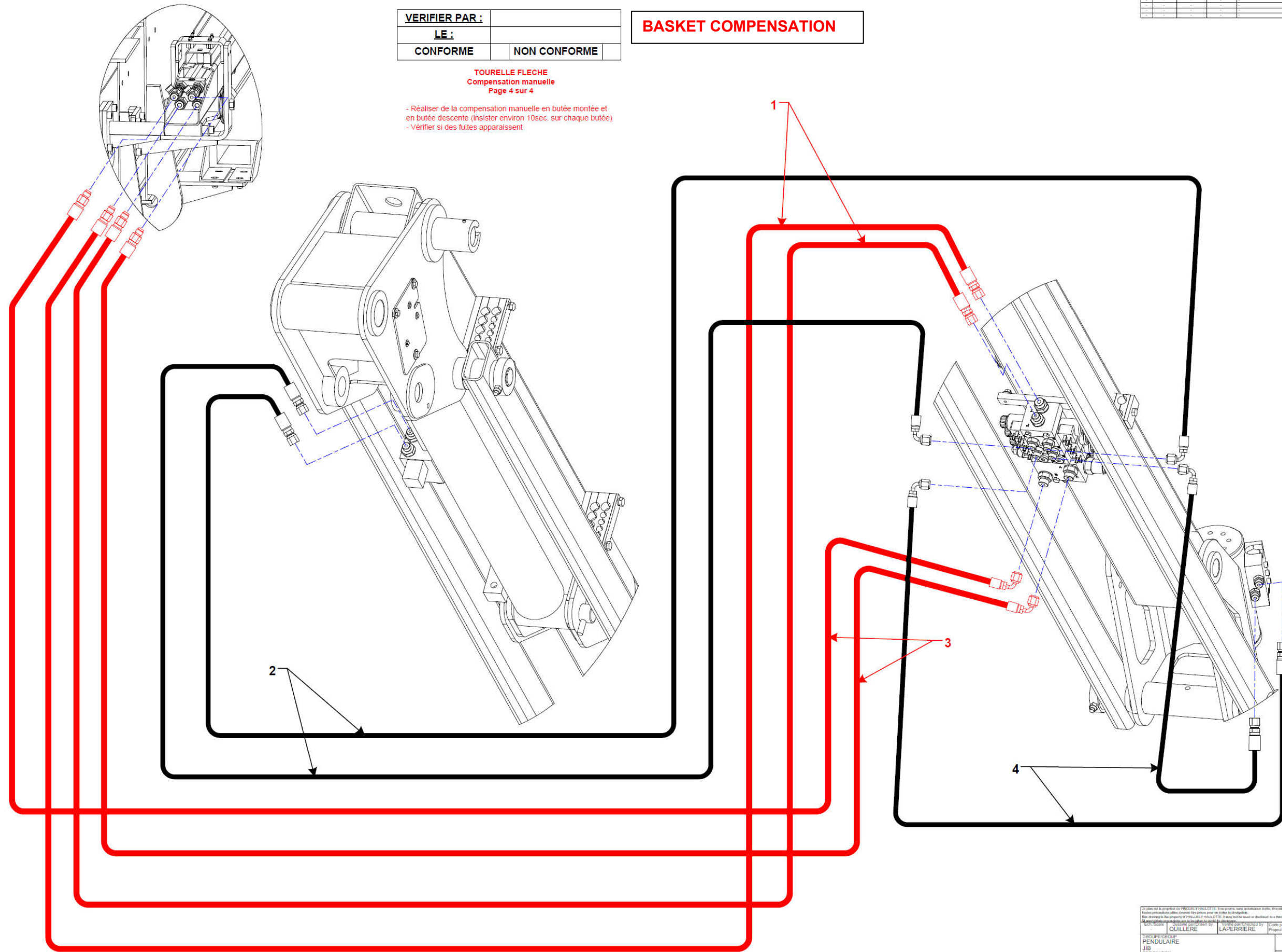

<small>                 Ce plan est propriété de Haulotte Services. Il ne peut être réutilisé sans autorisation écrite. Toute réimpression ou utilisation sans autorisation est formellement interdite. Toute violation sera poursuivie.             </small>			
<small>                 Dessiné par                  QUILLERE             </small>	<small>                 Vérifié par                  LAPERRIERE             </small>	<small>                 Code projet                  159             </small>	<small>                 Date                  18/06/2009             </small>
<small>                 Désignation                  HYDRAULIQUE PENDULAIRE             </small>			<small>                 N° de pièce                  A0159P325060             </small>

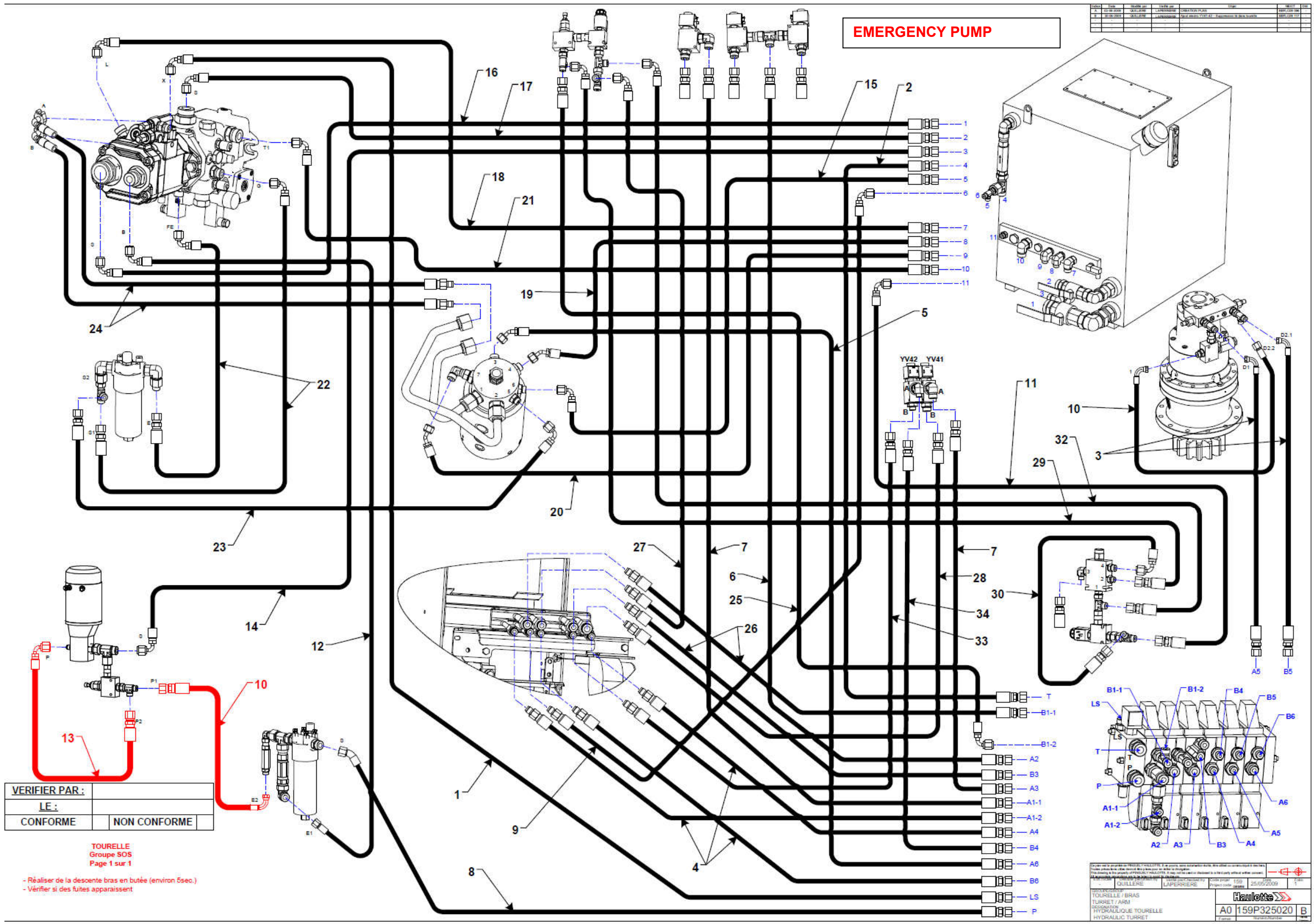

**EMERGENCY PUMP**

Code	Date	Version	Etat	Approuvé	Revisé
1	20/03/2009	1	Final		
2	20/03/2009	1	Final		

VERIFIER PAR :	
LE :	
CONFORME	NON CONFORME

**TOURELLE**  
Groupe SOS  
Page 1 sur 1

- Réaliser de la descente bras en butée (environ 5sec.)
- Vérifier si des fuites apparaissent

PROJET	TOURELLE / BRAS	DATE	25/05/2009
QUILLERE	LAPERMIERE	PROJET	159
TOURELLE / BRAS		HAULOTTE	
TURRET / ARM		A0 159P325020 B	
HYDRAULIQUE TOURELLE		E12-21	
HYDRAULIC TURRET			



## 4. ADJUSTMENTS

---

### 4.1. ADJUSTMENTS WITH OPTIMIZER CONSOLE

The adjustments, parameter settings and lists of alarms of the machine are accessible only through this console.

#### Connection bottom panel (turret)

On plug socket RS232 located outside the lower control box

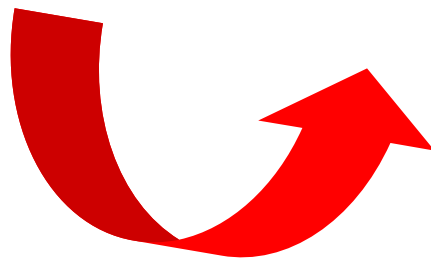
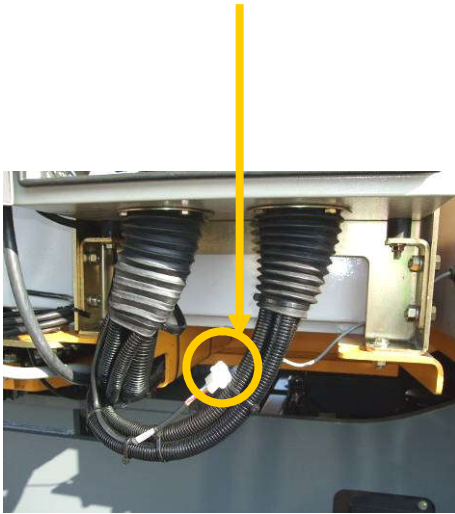



Description of the console

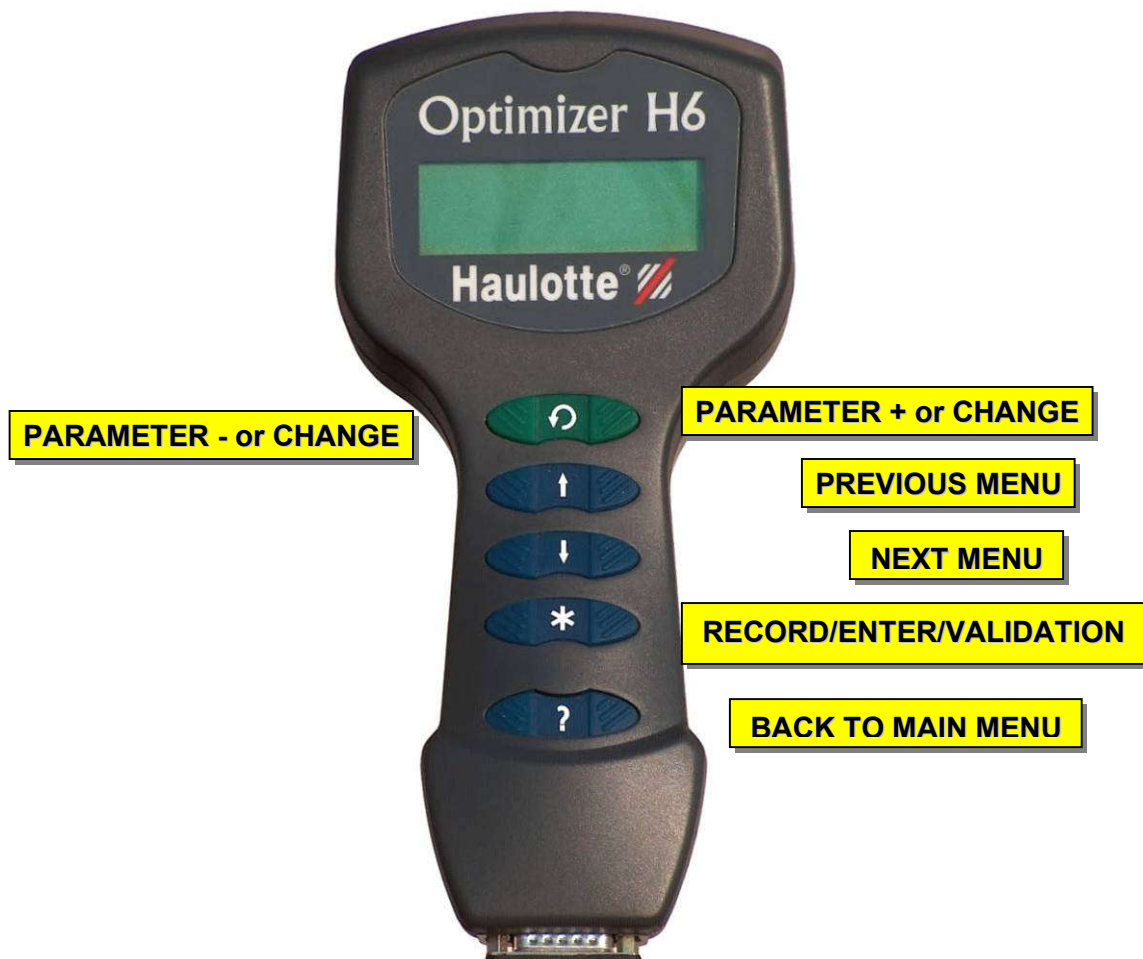

**NOTE :** on any blue key pads , pressing on left , right or in the center have the same result

List of menus

Access to the main menu

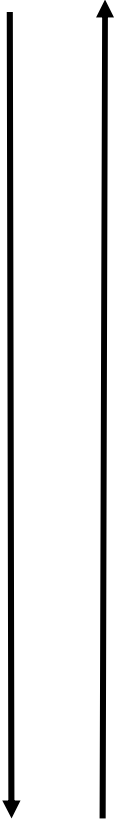

```
HAULOTTE GROUP
HA41PX NT AD000000
2901012700 V1.01 EUR
10:12 07/01/2010
```

1. CODE

Access code for restrictive parameters/calibration

2. PARAMETERS

Parameters setting access

3. INPUTS - OUTPUTS

Input/output state access

4. DIAGNOSTIC

Trouble shooting guide per function

5. INFORMATIONS

Machines status

6. FAILURES

Failures list

**Access to the code for restrictive parameters and options**

```
HAULOTTE GROUP  
HA41PX NT AD000000  
2901012700 V1.01 EUR  
10:12 07/01/2010
```

Scroll by key  
UP/DOWN

```
1. CODE
```

Validation by the key:  , then enter the code

```
Enter access code  
0000 Level 1  
^
```

Navigation by this key to enter the code (code following model)

```
Enter access code  
2031 Level 2  
^  
Code Ok
```

Level 2 is  
registered

press the key:

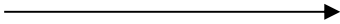

Back to main menu

The console is in level 2 (access to calibration menu)



### Access to the menus of parameters settings and option



HAULOTTE GROUP  
HA41PX NT AD000000  
2901012700 V1.01 EUR  
10:12 07/01/2010

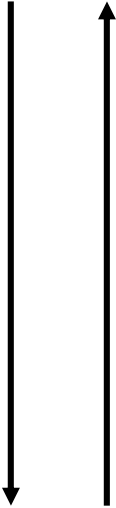

2. PARAMETERS

Scroll by key UP/DOWN

2.1 SPEEDS

Speed parameters adjust

2.2 RAMPS

ramp parameters adjust

2.3 OPTIONS

Options adjustment



press the key:

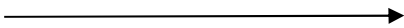

Back to main menu

The console is in level 2 (access to calibration menu)

**Access to the calibration**

HAULOTTE GROUP  
HA41PX NT AD000000  
2901012700 V1.01 EUR  
10:12 07/01/2010

2. PARAMETERS

Scroll by key UP/DOWN

2.4 MAINTENANCE

Access to maintenance  
(depends on the model)

2.5 FACTORY SETTINGS

Back to factory values

2.6 CALIBRATION

Access to diferent calibration  
steps  
(depends on the model)

2.6.2 CAL OVERLOAD

#### 4.1.1. CODES ALARMS

ALARMS		EVENTS	DESCRIPTION	COMMENTS
Alarm drive	TR01 (3 FLASH)	Defect on drive	Machine unfolded since more 3s and running in YV30A or YV30B higher than 650mA during more 200ms	Regulated CourantMaxMicro at 650mA
	TR02 (3 FLASH)	Defect valve high speed	Machine unfolded since more 3s and open B8 and FU8 present during more 500ms	check B8
	TR03 (3 FLASH)	Electric defect on drive	No drive since 100ms and open circuit on YV30A or YV30B since 100ms and FU70 present	Disconnected YV30A or disconnected YV30B or (YV30A or YV30B) supplied without validation of drive)
Alarm chain	CH01 (4 FLASH)	chain telescopic boom	FU8 present and (SQ12 or open SQ13)	check chain telescopic boom, SQ12, SQ13
Alarms joysticks	JY01 (2 FLASH)	Electric defect joystick JYB01	Electric defect joystick drive signal < 0.2V or > 4.8V or signal between 0.65Vet 2.35V and not in off neutral or signal between 2.65V and 4.35V and not in off neutral	check joystick JYB01
	JY02 (2 FLASH)	Electric defect joystick JYB02	Electric defect joystick telescoping signal < 0.2V or > 4.8V or signal between 0.65Vet 2.35V and not of off neutral or signal between 2.65V and 4.35V and not in off neutral	check joystick JYB02
	JY03 (2 FLASH)	Electric defect joystick JYB03	Electric defect joystick lifting signal < 0.2V or > 4.8V or signals between 0.65Vet 2.35V and not of off neutral or signal between 2.65V and 4.35V and not in off neutral	check joystick JYB03
Alarms position sensors	CA01 (1 FLASH)	SL1 out of range	Angle boom < -45° or > 75°	check SL1 + connections
	CA02 (1 FLASH)	SL2 out of range	Angle boom < -45° or > 75°	check SL2 + connections
	CA03 (1 FLASH)	SL3 out of range	Length boom < -150mm or > 5980+150mm	check SL3 + connections
	CA04 (1 FLASH)	SL4 out of range	Length boom < -150mm or > 5980+150mm	check SL4 + connections
	CA05 (1 FLASH)	SL5 out of range	Angle arm < - 5° or > 83°	check SL5 + connections
	CA06 (1 FLASH)	SL7 out of range	Length arm < - 150mm or > 7655 +150mm	check SL7 +connections
	CA07 (1 FLASH)	SL8 out of range	Length arm < - 150mm or > 7655 +150mm	check SL8 + connections
	CA08 (1 FLASH)	Error between SL1 and SL2	Inconsistency of reading between the 2 sensors (> 3°)	check SL1 and SL2 + connections



	CA09 (1 FLASH)	Error between SL3 and SL4	Inconsistency of reading between the 2 sensors (> 250mm°)	check SL3 and SL4 + connections
	CA10 (1 FLASH)	Error between SL7 and SL8	Inconsistency of reading between the 2 sensors (> 250mm°)	check SL7 and SL8 + connections
	CA11 (1 FLASH)	Error between sensors boom	Inconsistency between angle boom and SQ3H (angle boom >55° and SQ3H=1)	check SQ3H + connection
	CA12 (1 FLASH)	Error between sensors boom	Inconsistency between angle boom and SQ3L (angle boom < - 5° and SQ3L=1)	check SQ3L + connections
	CA13 (1 FLASH)	Error between sensors boom	Inconsistency between angle boom and SQ11 (angle boom > 10° or < -10° or Angle arm > 10° and SQ11=1)	check SQ11 + connections
	CA14 (1 FLASH)	Error between sensors arm	Inconsistency between angle arm and SQ7 (Angle arm < 74° and SQ7 =1)	check SQ7 and SL5 + connections
	CA15 (1 FLASH)	Error between sensor arm and Link piece	Inconsistency between angle arm and SQ27 (Angle arm > 10° and SQ27=1)	check SQ27 and SL5 + connections
	CA16 (1 FLASH)	Error between sensors arm	Inconsistency between length arm and SQ10 (Angle arm > 200m and SQ10=1)	check SQ10 and SL7 and SL8 + connections
	CA17 (1 FLASH)	Error calculation arm zones	Inconsistency between length arm and sensors ILS SQ44/SQ45 Zone 0 (1st magnet with 0mm) Zone 2 (2nd magnet with 640mm) Zone 4 (3rd magnet with 1280mm) Zone 6 (4th magnet to 1920 mm) Zone 8 (5th magnet with 2560mm) Zone 10 (6th magnet with 3200mm) Zone 12 (7th magnet with 4480mm) Zone 14 (8th magnet with 5120mm) Zone 16 (9th magnet with 5760mm) Zone 18 (10th magnet with 6400mm) Zone 20 (11th magnet with 7040mm) Fine 21 zones (defect if inconsistency between length and release zones > 140 mm)	check ILS SQ44-SQ45 - magnets and SL7 - SL8 + connections
	CA18	Error between sensors boom	Inconsistency between length boom and SQ9 (length boom > 200mm and SQ9 =1)	check SQ9 and SL3 - SL4 + connections

	CA19	Error calculation boom zones	Inconsistency between length boom and SQ43 (zones ILS) Zone 0 (1st magnet with 0mm) Zone 2 (2nd magnet with 3796mm) Zone 4 (3rd magnet with 4246mm) Zone 6 (4th magnet to 4696 mm) Zone 8 (5th magnet with 5146mm) Zone 10 (6th magnet to 5596 mm) Fine zones 11 (defect if inconsistency between length and release zones > 140 mm)	check ILS SQ43 - magnets and SL3-SL4 + connections
	CA20	Error between arm sensors	Inconsistency between zones arm SQ44-SQ45 and SQ10 (zones arm $\geq 2$ and SQ10=1)	check SQ44-SQ45 - SQ10 + connections
	CA21	Error between boom sensors	Inconsistency between zone boom SQ43 and SQ9 (zones boom $> 2$ and SQ9 =1)	check SQ43-SQ9+ connections
	CA26	Error between sensors	Inconsistency between arm angle $> 77^\circ$ and SQ7=0)	Check SQ7 and SL5 (stowed position, is possible to clear the alarm)
Alarm reach limitation boom	LP01 (8 FLASH)	Reach limitation arm	Reach limitation arm (angle arm $< 74^\circ$ and length arm $> 500$ mm)	sensors reach limitation (SL1, SL2, SL3, SL4, SL5 +, valves YV3/YV4/YV6 and YV7
	LP02 (8 FLASH)	Reach limitation Front boom	Reach limitation boom (angle arm $< 70^\circ$ and angle boom $> 58^\circ$ )	
Alarm reach limitation boom	LP03 (8 FLASH)	Reach limitation Rear boom	Reach limitation Boom (abacus error $> 350$ mm)	sensors reach limitation (SL1, SL2, SL3, SL4, SL5 +, valves YV3/YV4/YV6 and YV7
Alarm system of weighing	OL01 (9 FLASH)	System weighing absent	System off-line or not parameterized	check parameter setting + connections (in particular CN106.18 module B1 node)
Alarm system of weighing	OL02	System weighing not gauged	System not gauged	Proceed to the load calibration
Alarm system of weighing	OL03	Defect weighing	Defect sensor relative Angle A1	check A1+ connections
Alarm system of weighing	OL04	Defect weighing	Defect sensor absolute angle A2 (inclinometer)	check A2+ connections
Alarm system of weighing	OL05	Defect weighing	Defect sensor G1 pressure small chamber jib cylinder	check G1+ connections
Alarm system of weighing	OL06	Defect weighing	Defect sensor G2 pressure large chamber jib cylinder	check G2+ connections

Alarm system of weighing	OL07	<del>Error of calculation</del>	<del>Error of calculation in the system of weighing</del>	Cancelled from serial number AD124603 or with software > V1.03
Alarm system of weighing	OL08	<del>Problem of weighing</del>	<del>Problem of module</del>	
Alarm system of weighing	OL09	Pressure error	Inversion of connection between pressure sensors G1 and G2	check connection
Alarms fuses	AL01 (6 FLASH)	FU70 at 0	Destroyed FU70	change fuse FU70
	AL02 (6 FLASH)	FU8 at 0	Destroyed FU8	change fuse FU8
	AL03 (6 FLASH)	Problem of fuses and selector SA1	Problem of key selector SA1 (FU5 - FU6 and FU2 = 1 or FU5 - FU6 and FU2 =0)	check selector SA1
Alarm circuit of emergency stop	AU01 (5 FLASH)	Defect circuit of stop emergency KMG1	Defect circuit of emergency stop KMG1 (254 = 0 and FU70=1)	check circuit of emergency stop, KMG1
Alarm battery computer	BT01	Year provided by the clock equal to 2000 when ON	Year of the date in module = 2000 when ON	replace module Head (node A)
Alarm EEPROM computer	EP01	Defect EEPROM computer	Defect EEPROM Head	replace module Head (node A)
CAN BUS Alarm	MX01	Defect CAN BUS	Defect CAN BUS line	check FU16 , CAN - BUS + modules Node A and B1



#### 4.1.2. MAIN MENU

<b>2.3 OPTIONS</b>	BUZZ-TRANS	buzzer drive	+/- for modification , + , * in order to keep Active or Inactive)
	BUZZ-MVTS	buzzer mouvement	
	No dead Man Tur	no dead man turret	
	European mode	Option to validated (level 3)	
	Australia mode	Option to validated (level 3)	
	USA mode	Option to validated (level 3)	
<b>2.4 MAINTENANCE</b>	Cancel Overload	Cancel the overload	
	All secu valves ON	Pilot YV41, YV42, YV34, YV38, YV35 and YV36.	in static mode permits to check the proofness of hydraulic circuit and its components ( example CB valves).
	All secu valves OFF	no pilot on valves YV41, YV42, YV34, YV38, YV35 and YV36.	in dynamic mode permits to check the proofness of the safety valves. (example : activate arm lift and no movement as YV38 is OFF).
	Factory tolerances	Reduce the tolerances sensors fault of 30% .	check the machine with restrictive tolerances.
	! Only for factory !	Cancel some safety features	Not to be used on field .
<b>2.5 FACTORY SETTINGS</b> <i>Access through level 2 and/or 3 code</i>	Factory Settings ?	Defaults values for ( ramps , speed , options)	* for validation
<b>2.6.1 CALIBRATION</b> <b>Reach limit</b> <i>Access only with level 3 code</i>	Px : Cancel Reach lim?	Calibration reset	+/- erase the calibration - Level 3
	P1 : Machine stowed ?	step 1 : machine in stowed position	+/- for calibration - level 3
	P2 : Boom to 70° ?	step 2 : boom at maximum height	+/- for calibration - level 3
	P3 : Teles boom out ?	step 3 : telescopic boom extension fully OUT	+/- for calibration - level 3
	P4 : Boom tele in ?	Step 4 : Telescopic boom extension fully IN	+/- for calibration - level 3

	P5 : Boom to 0° ?	step 5 : boom in stowed position	+/- for calibration - level 3
	P6 : Arm to 78° ?	step 6 arm fully lifted (at maximum height)	+/- for calibration - level 3
	P7 : Teles Arm in ?	step 7 : both telescopic arm extension fully OUT)	+/- for calibration - level 3
	P8 : Boom to - 40° ?	step 8 : lower the boom at its lowest position	+/- for calibration - level 3
	P9 : Boom to + 5° ?	step 9 : boom lifted above horizontal	+/- for calibration - level 3
	P10 : Arm to 0° ?	step 10 : arm down in stowed position	+/- for calibration - level 3
	P11 : Boom to 0° ?	step 10 : put back the boom in stowed position	+/- for calibration - level 3
<b>2.6.2 Cal Overload</b> <i>Accessible from level 2</i>	Start jib learning ?	Start the load calibration on jib (lift step by step)	follow instructions on screen or see TN126
<b>2.7 SERIAL NUMBER</b> <i>Accessible only in level 3</i>	ADxxxxxx	Serial number of the machine.	+/- for modify, + and - for the defect vaue, * for register value
<b>Menu 3. INPUTS - OUTPUTS</b>			
<b>DIGITALS INPUTS</b>		<b>INPUT NODE A (lower controls)</b>	
	SQ34	magnetic switch for front outriggers detection	"ON" if front outrigger is IN
	SA13U	boom lift toggle switch	"ON" if pushed
	SA13D	boom descent toggle switch	"ON" if pushed
	SQ35	magnetic switch for rear outriggers detection	"ON" if rear outrigger is IN
	SA14U	arm descent toggle switch	"ON" if pushed
	SA14D	arm lift toggle switch	"ON" if pushed
	SQ31	front right axle extended switch detection	"ON" if pushed
	SA15L	left turntable rotation toggle switch	"ON" if pushed
	SA15R	right turntable rotation toggle switch	"ON" if pushed
	SQ30	front left axle extended detection switch	"ON" if extended
	DPLUS	Alternator	"ON" if alternator is sending current
	KMG1	KMG survey relay	"ON" if KMG is powered
	SA21D	basket compensation descent toggle switch	"ON" if pushed
	SA21U	basket compensation lift toggle switch	"ON" if pushed
	SQ11	boom limit switch stowed position detection	"ON" if boom is on the turret

SB3	engine start/stop switch	"ON" if pushed
SA2	Accelerator toggle switch	"ON" if pushed
SQ43	proximity sensor ILS for boom telescopic extension detection	"ON" if magnet
SQ44	proximity sensor ILS for arm telescopic extension 1 detection	"ON" if magnet
SQ7	arm limit switch stowed position detection	"ON" if arm is in upper position(78°)
SQ9	telescopic boom extension limit switch position detection	"ON" if telescopic boom extension IN
SQ12	chain break limit switch detection	"OFF" if chain broken
SA6U	jib lift toggle switch	"ON" if pushed
SA6D	jib descent toggle switch	"ON" if pushed
SA19 SOS	toggle switch for emergency pump run	"ON" if pushed
SQ10	telescopic arm extension limit switch position detection	"ON" if telescopic arm extension IN
SQ1	slope sensor	"OFF" if in ramp or slope
B4	oil temperature switch	"OFF" if oil overheated
SQ3L	lower boom limit switch detection	"ON" if boom > 0°
SQ45	proximity sensor ILS for arm telescopic extension é detection	"ON" if magnet
SQ38	Proximity sensor ILS for front axle position detection	"ON" if extended or retracted
SQ36	Proximity sensor ILS for rear axle position detection	"ON" if extended or retracted
SQ40	turntable limit switch detection	"ON" if turret is aligned
SQ27	proximity sensor ILS for link part compensation position detection	"ON" if link part is OK
SA19 DM	dead man toggle switch for movements	"ON" if pushed
FU70	fuse state	"OFF" if fuse blown
FU8	fuse state	"OFF" if fuse blown
Basket box	Selection turret control box	"ON" if selected
Turret box	Selection basket control box	"ON" if selected
SQ32	right rear axle limit switch detection	"ON" if extended
SQ33	left rear axle limit switch detection	"ON" if extended
Frame box	selection chassis movements	"ON" if selected
SB7	preheating switch	"ON" if pushed
B8	high speed pressure switch	"OFF" if in HS
SA8I	telescopic retraction toggle switch	"ON" if pushed
SA8O	telescopic extension toggle switch	"ON" if pushed



	SQ42	proximity sensor ILS turntable position detection	"ON" if in front of magnet and turret aligned
	SQ13	chain break limit switch detection	"OFF" if chain broken
	SQ3H	upper boom position limit switch detection	"ON" if boom < 50°
	B2	engine oil temperature sensor	"ON" if overheating
	B3	engine oil pressure sensor	"ON" if lack of pressure
	SQ41	fuel level indicator	"ON" if too low
	<b>INPUTS NODE B ( upper controls)</b>		
	SWB08	horn toggle switch	"ON" if pushed
	SWB07	differential lock switch	"ON" if pushed
	JYB01R	front right steering on drive joystick	"ON" if pushed
	JYB01L	front left steering on drive joystick	"ON" if pushed
	SWB05	high speed switch selection	"ON" if in Low Speed
	SWB03U	basket compensation lift switch	"ON" if pushed
	SWB03D	basket compensation descent switch	"ON" if pushed
	SWB02	Generator pushbutton	"ON" if pushed
	SWB11U	jib lifting switch	"ON" if pushed
	SWB11D	jib descent switch	"ON" if pushed
	SWB13R	right basket rotation switch	"ON" if pushed
	SWB13L	left basket rotation switch	"ON" if pushed
	SWB12	switch selection for arm	"ON" if arm is selected
	SWB16	engine start/stop push button	"ON" if pushed
	SWB17	emergency pump push button	"ON" if pushed
	JYB01HNF	FWD drive joystick neutral position	"ON" if joystick pushed
	JYB01HNB	REV drive joystick neutral position	"ON" if joystick pulled
	JYB02HN	telescopic joystick arm/boom neutral position	"ON" if joystick pushed
	JYB03HN	turret rotation /boom lift joystick neutral position	"ON" if joystick pushed
	SWB06R	left rear steering switch	"ON" if pushed
	SWB06L	right rear steering switch	"ON" if pushed
	SB6	foot dead man switch (pedal)	"ON" if pushed
<b>DIGITALS OUTPUTS</b>	<b>OUTPUTS NODE A</b>		
	YV1	LS valve	
	HL20	flashing light option	
	KM24	generator contactor ( option)	
	YV22A	rear right steering valve	
	YV22B	rear left steering valve	
	YV10	high speed valve	

YV8 31A	Extension outriggers/steering valve	
YV8 31B	Extension outriggers/steering valve	
GND-YV6	ground on telescopic arm PVG valve	
GND-YV3	ground on arm lifting PVG valve	
YV38	arm lifting safety valve	
YV35	telescopic arm extension 1 safety valve	
YV36	telescopic arm extension 2 safety valve	
GND_YV4	ground on boom lifting PVG valve	
GND_YV5	ground on turrtable rotation PVG valve	
YV9	differential lock valve	
GND_YV2	ground on valve	
YV33	oscillatong axle unlocking valve	
KM4	emergency pump contactor	
KM5	Pre heating contactor	
HL17	turrret outreach lmitation light indicator	
HA4	Buzzer on turret	
KP1	Stop engine relay	
KA2	starter relay	
HL4	oil pressure indicator	
HL3	oil temperature indicator	
HL16	overload indicator on turret	
KA37	command for accelerator coil	
GND_YV7	ground on boom telescopic extension PVG valve	
KA1	relay for horn	
YV34	turntable unbraking valve	
YV42	boom descent safety valve	
<b>OUTPUTS NODE B (upper controls)-</b>		
LTB09	not used	
BZB01	Buzzer	
LTB08	not used	
LTB07	outreach limitation indicator	
LTB06	overload light	
LTB05	slope light	
LTB04	fault light	
LTB03	low level fuel indicator	
LTB02	power presence light	
LTB01	foot dead man switch indicator	
YV15B	basket compensation lift	
YV15A	basket compensation descent	
YV18B	Jib lift	
YV18A	jib descent	
YV19B	left basket rotation	

	YV19A	right basket rotation	
<b>ANALOG INPUTS</b>	<b>INPUTS NODE A-</b>		
	SL7	signal of the telescopic arm length sensor ( extension 1)	0 to Vbatt (12V)
	SL8	signal of the telescopic arm length sensor ( extension 2)	0 to Vbatt (12V)
	SL1	boom angle sensor signal	4 - 20mA
	SL2	boom angle sensor signal	4 - 20mA
	SL5	arm angle sensor signal	4 - 20mA
	VBAT	battery voltage	0 to 16V
	<b>INPUTS NODE B</b>		
	G1	pressure sensor on jib small chamber	0-5V
	G2	pressure sensor on jib large chamber	0-5V
	JYB01Y	drive joystick signal	4,5VDC - 2,5 VDC-0,5VDC
	JYB02Y	telescopic arm/boom joystick signal	4,5VDC - 2,5 VDC-0,5VDC
	JYB03Y	boom lift joystick signal	4,5VDC - 2,5 VDC-0,5VDC
	JYB03X	turntable joystick signal	4,5VDC - 2,5 VDC-0,5VDC
	A2	load absolute angle sensor value (inclinometer)	0 to Vbatt (12V)
	SL3	telescopic boom length sensor value number 1	0 to Vbatt (12V)
SL4	telescopic boom length sensor value number 2	0 to Vbatt (12V)	
A1	load relative angle sensor value	0 to Vbatt (12V)	
<b>ANALOG OUTPUTS</b>	<b>OUTPUTS NODE A</b>		
	YV30A	PWM ( Pulse width Modulation) signal	from 0 to 1115mA
	YV30B	PWM ( Pulse width Modulation) signal	from 0 to 1115mA
	YV2	PVG signal on ON/OFF block	25% - 50% - 75% of Vbatt
	YV5	PVG signal for turntable rotation	25% - 50% - 75% of Vbatt
	YV6	PVG signal on telescopic arm	25% - 50% - 75% of Vbatt
	YV7	PVG signal on telescopic boom	25% - 50% - 75% of Vbatt
	YV3	PVG signal for arm lifting	25% - 50% - 75% of Vbatt
YV4	PVG signal on boom lifting	25% - 50% - 75% of Vbatt	



MENU 4. DIAGNOSTIC			
Reach limit	Arm angle	state	Not calib = the system must be calibrated.OK = the system is OK.Failure(s) = restrictive mode.
	Arm length	state	
	Boom angle	state	
	Boom length	state	
	Abacus	theoretical abacus (rear outreach limitation)	in mm
Arm	SL5 angle	SL5 angle sensor value	in deg x100
	SQ7	arm ON/OFF limit switch position	ON if arm > 75,5°
	SQ27	link part position ILS sensor value	ON if in front of a magnet
	SL7 length	telescopic arm length sensor value	in mm
	SL8 length	telescopic arm length sensor value	in mm
	Arm Zone	arm ILS sensor zone	must be between 0 and 21
	SQ10	state of the limit switch when telescopic arm is IN	ON if telescopic arm extension is fully IN
	SQ44	ILS zone detection on telescopic arm extension 1	ON if in front of a magnet
	SQ45	ILS zone detection on telescopic arm extension 2	ON if in front of a magnet
Boom	SL1 angle	bomm angle value	in deg x 100
	SL2 angle	bomm angle value	in deg x100
	SQ11	state of the limit switch when boom is stowed	ON if boom is in stowed position
	SQ3H	state of the imit switch when boom is in upper position	ON if boom angle is between -40° and +50°
	SQ3L	state of the imit switch when boom is in lower position	ON if boom angle is > + 0°
	SL3 length	boom length value	in mm
	SL4 length	boom length value	in mm
	SQ9	state of the limit switch when telescopic boom is IN	ON if telescopic boom extension is fully IN
	SQ43	ILS zone detection on telescopic boom	ON if in front of a magnet
	Boom Zone	ILS zone on boom	must be between 0 and 11
	Error	error between theoretical abacus and the real boom position	in mm
Overload	Jib angle	relative angle on jib angle	in deg x 10
	Abs. Angle	absolute value on jib angle	in deg x 10
	Rod .pressure	jib small chamber pressure value	in bar x 10
	Bore pressure	jib large chamber pressure value	in bar x 10

Other	Axle out	sensors state SQ30/SQ1/SQ32/SQ33/SQ36/ SQ38 "axle extended"	OK if SQ30 up to SQ33 =1 and SQ36+ SQ38 =1
	Axle in	sensors state SQ30/SQ1/SQ32/SQ33/SQ36/ SQ38 "axles retracted"	OK if SQ30 up to SQ33 =0 and SQ36+ SQ38 =1
	Node B	software version on node B	
<b>MENU 5. INFORMATIONS</b>			
DATE AND HOUR	Date and hour		* to modify (only in level 3)
VERSIONS	Versions software		
JOURNAL 1	not available		

### 4.1.3. PARAMETER SETTINGS

The values given are those activated from the upper controls (axles in position extended)  
 The adjustments and controls must be carried out with hot hydraulic oil (temperature between 30°C and 50°C)

Times must be taken with a stop watch (release with the command the movement)

The movements from lower controls are 85% slower from upper controls

	DISPLAY on console	Movement	Time (seconds)
<b>Upper controls</b>	p jib up	jib raise	<b>40 + 2 sec</b>
	P jib down	Jib descent	<b>48 + 2 sec</b>
	p plat rotate	Basket rotation (ful stroke)	<b>15 + 2 sec</b>
	p plat level	Basket compensation (stroke from -10° to + 10°)	<b>26 + 2 sec</b>
	p arm up	Arm lift	<b>58 + 2 sec</b>
	p arm down	Arm descent	<b>45 + 2 sec</b>
	p arm ext. in	retraction of the 2 telescopic arm	<b>57 + 2 sec</b>
	p arm ext. out	extension of the 2 telescopic arm	<b>48 + 1 sec</b>
	p boom up	Boom lift (telescope retracted maximum angle 48°)	<b>50 + 2 sec</b>
	p boom down	Boom descent (telescope retracted descent from 48° until 0)	<b>54 + 2 sec</b>
	P boom up	boom lift 0 to 48° (telescope OUT)	<b>74 + 2 sec</b>
	P boom down	boom descent 48° to 0 (telescope OUT)	<b>60 +/- 2 sec</b>
	p boom ext. in	Retraction telescope boom (horizontal boom cut-off at 0)	<b>21 + 2 sec</b>
	p boom ext. out	extension telescope boom (horizontal boom cut off at 0)	<b>16 + 2 sec</b>
p turret left/right	Left/right orientation (retracted boom)	<b>40 + 2s on ¼ turn</b>	
p turret left right (nonadjustable)	Left/right orientation (boom OUT in horizontal to the maximum of the range)	<b>76 + 2s on ¼ turn</b>	
drive FWD	High speed drive FWD (5km/h)	<b>38 + 2s on 50 m</b>	
drive REV	High speed drive REV(5 km/h)	<b>38 + 2s on 50 m</b>	
Micro speed FWD	Micro speed FWD drive (0.45km/h)	<b>49 + 2s on 5 m</b>	
Micro speed REV	Micro speed REV drive (0.45km/h)	<b>49 + 2s on 5 m</b>	
<b>Checking of the movements</b>			
DEC Trans FWD	deceleration High Speed drive FWD	<b>Stop into 1,20 m maximum.</b>	
DEC Trans REV	deceleration High Speed drive REV		



## 4.2. HAULOTTE DIAG CONSOLE

It's possible to use the 2<sup>nd</sup> generation of diagnostic console (also available through laptop, IOS, iPhone..)

The presentation of the main menu will depend of the software's version of the machine

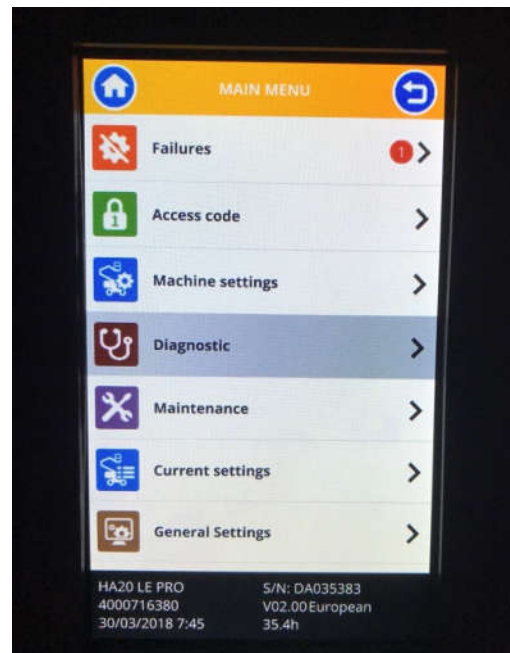
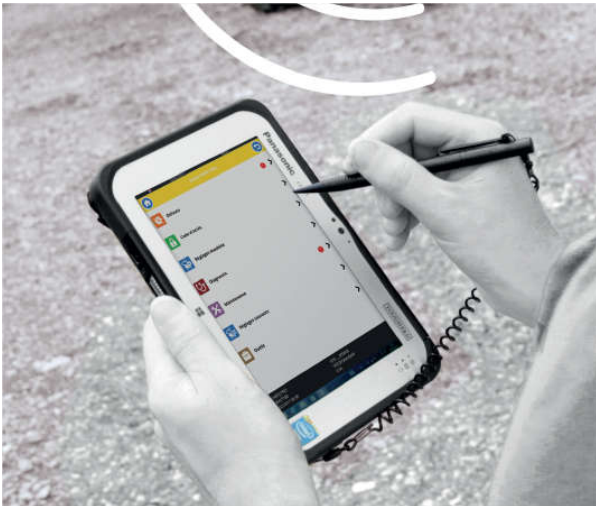
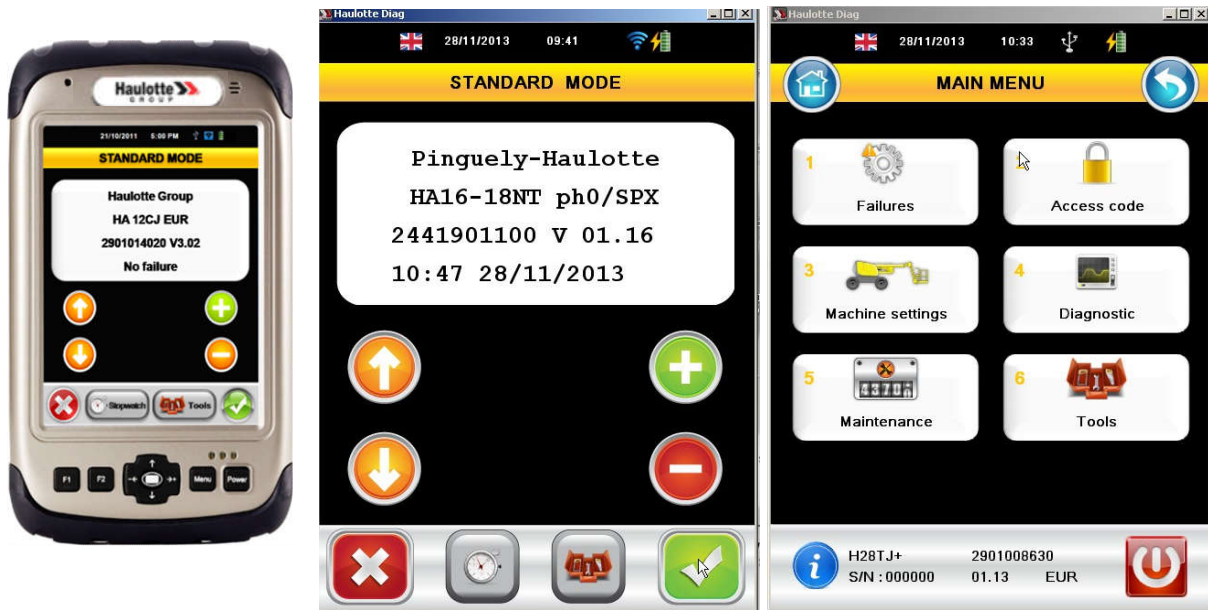

These devices could be used in WIFI using a VCI adapter (Vehicle Computer Interface)



The full description of how to use that console and their menus is explained in an other technical note (refer to your nearest HAULOTTE SERVICES of your area)

Note: With that 2<sup>nd</sup> generation of console, the name of alarm's code has been changed (not the description and function)

The 1<sup>st</sup> table is referring to models equipped with ECU module Node B1 in upper controls box

New failure code	Original failure code	Description
F02.03.1	AU01	Main relay fault
F05.01.2	JY01	Drive Joystick
F05.03.1	JY02	Telescope joystick
F05.06.2	JY03	Boom / Turret Joystick
F06.01.1	OL01 - OL02	No overload calibration
F06.02.1	OL09	Incoherence pressure node
F07.02.1	CH01	Chain not adjusted properly or cable broken
F07.03.2	CA01	Boom angle
F07.03.3	CA02	Boom angle
F07.03.4	CA08	Boom angle
F07.04.4	CA11 – CA12 – CA13	Boom angle position
F07.06.1	CA05	Arm angle
F07.07.2	CA14 – CA26	Arm angle position
F07.07.3	CA15	Arm angle position
F07.08.1	CA06	Arm Length
F07.08.2	CA07	Arm Length
F07.08.3	CA10	Arm Length
F07.09.2	CA16	Arm Length Position
F07.09.3	CA17	Arm Length Position
F07.09.4	CA20	Arm Length Position
F07.10.2	CA03	Telescope length
F07.10.3	CA04	Telescope length
F07.11.5	CA18	Telescope length Position
F07.11.6	CA19	Telescope length Position
F07.11.7	CA21	Telescope length Position
F07.20.1	OL05	Rod end pressure transducer
F07.21.1	OL06	Bore end pressure transducer
F07.22.1	OL03	Relative angle transducer error
F07.23.1	OL04	Absolute angle transducer error
F08.02.1	AL01	Supply fuse

F08.03.1	AL02	Supply fuses 2
F08.07.1	AL03	Circuit selector
F10.01.1	TR01	Drive
F10.02.1	TR02	Drive 2
F10.03.1	TR03	Drive 3
F10.08.1	LP03	Reach Limit
F10.09.1	LP01	Reach Limit arm
F10.10.1	LP02	Reach Limit boom
F12.01.1	MX01	CAN BUS Fault
F12.02.1	EP01 – EP02	EEPROM Read / Write
F12.03.1	BT01	ECU Battery Low power

The 2<sup>nd</sup> table is referring to models TN122 equipped with metallic upper control box and BPE board for overload detection

New failure code	Original failure code	Description
F02.03.1	AU01	Main relay fault
F05.01.2	JY01	Drive Joystick
F05.03.1	JY02	Telescope joystick
F05.06.2	JY03	Boom / Turret Joystick
F06.01.1	OL01	No overload calibration
F06.02.1	OL09	Incoherence pressure node
F07.02.1	CH01	Chain not adjusted properly or cable broken
F07.03.2	CA01	Boom angle
F07.03.3	CA02	Boom angle
F07.03.4	CA08	Boom angle
F07.04.4	CA11 – CA12 – CA13	Boom angle position
F07.06.1	CA05	Arm angle
F07.07.2	CA14	Arm angle position
F07.07.3	CA15	Arm angle position
F07.08.1	CA06	Arm Length
F07.08.2	CA07	Arm Length
F07.08.3	CA10	Arm Length
F07.09.2	CA16	Arm Length Position
F07.09.3	CA17	Arm Length Position
F07.09.4	CA20	Arm Length Position
F07.10.2	CA03	Telescope length
F07.10.3	CA04	Telescope length
F07.11.5	CA18	Telescope length Position
F07.11.6	CA19	Telescope length Position
F07.11.7	CA21	Telescope length Position
F08.02.1	AL01	Supply fuse
F08.03.1	AL02	Supply fuses 2
F08.07.1	AL03	Circuit selector
F10.01.1	TR01	Drive
F10.02.1	TR02	Drive 2
F10.03.1	TR03	Drive 3
F10.08.1	LP03	Reach Limit
F10.09.1	LP01	Reach Limit arm
F10.10.1	LP02	Reach Limit boom
F12.02.1	EP01	EEPROM Read / Write
F12.03.1	BT01	ECU Battery Low power



### 4.3. ADJUSTMENT OF THE PRESSURES

#### 4.3.1. TABLE OF PRESSURES

DESIGNATION	In Bars
General	242 +-2
Load Sensing	35 +-2
Standby unit	135 +-2
Lifting arm high stop	190 + 2
Lifting arm low stop	242 +-2
Telescoping arm retracted	190 +-2
Boom lift highest stop	245 +-2
Boom lift lowest stop	165 +-5
Link part compensation	465 bars
Telescoping boom extension	100 -0/+10
Telescoping retracted boom	242 +-2
Turret slewing	115 +-2
Movements ON/OFF	245 +-5
Extension chassis front axle	90 +-2
Retraction chassis front axle	145 +-2
extension rear axle	110 +-2
Retraction rear axle	165 +-2
Charge circuit (gavage)	25 bars
Drive FWD/REV	320 bars

### 4.3.2. PRESSURE PORT

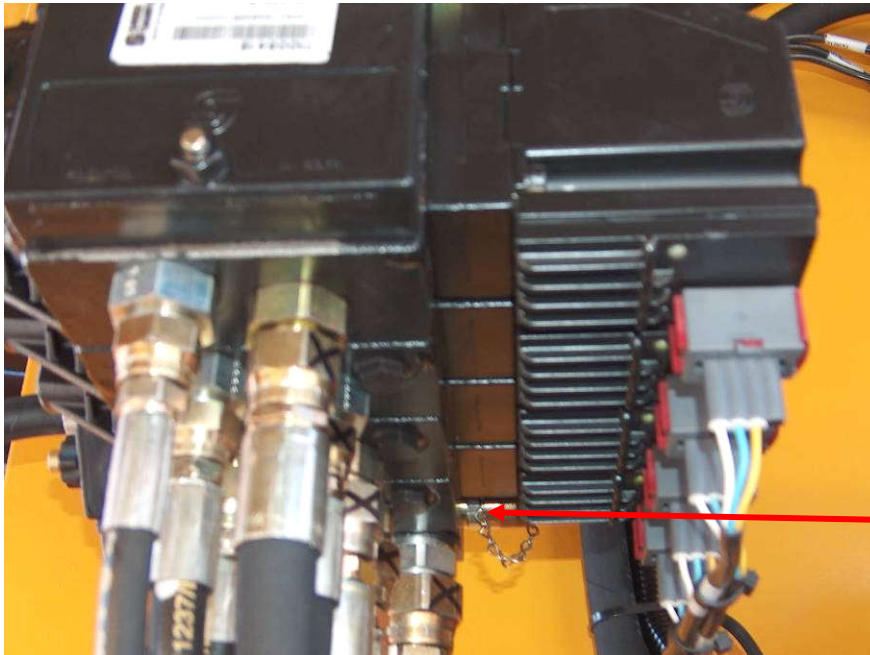
**M**

### 4.3.3. EQUIPMENT PUMP

Load sensing (LS)

The pump is preset with a Load Sensing pressure of 35b (+-2b)

The pump is preset with a general pressure of 242b (+-2b)

The cubic capacity of the pump is preset in order to reach the high-speed drive in 18 seconds for 25m

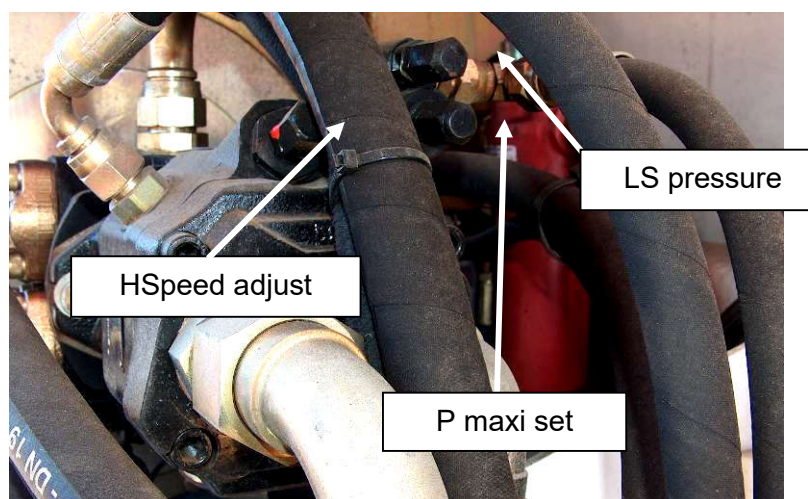

**4.3.4. DRIVE PUMP**

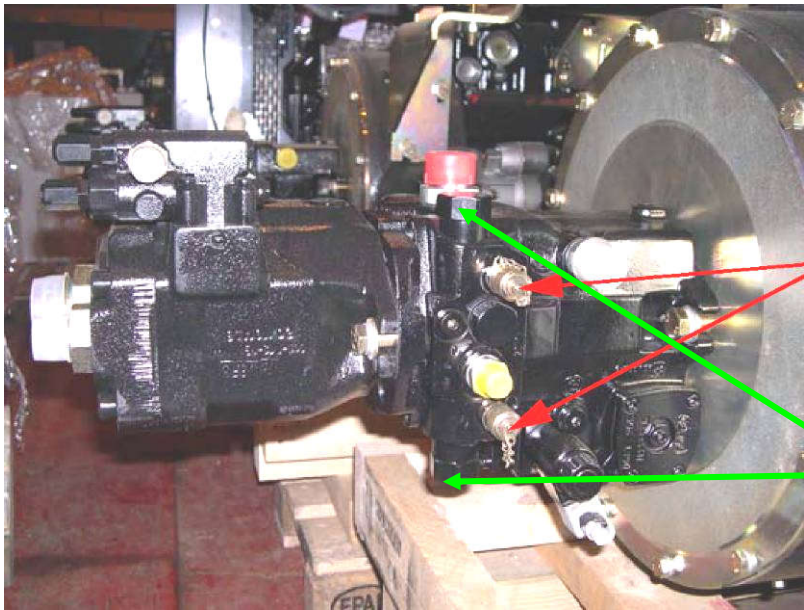

Pmaxi drive  
320 bars

Chock valves  
(counterbalances valves)  
350 bars

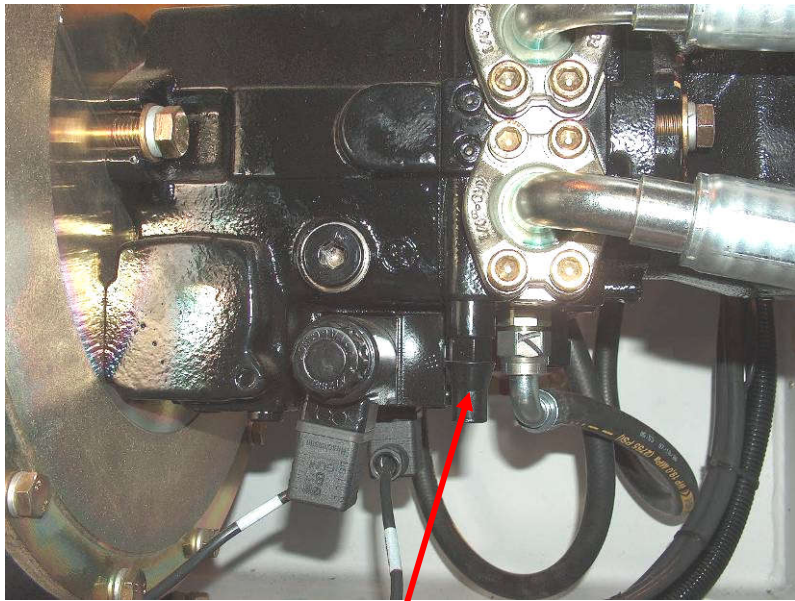

High Speed drive adjustment



## 5. BREAKDOWN SERVICE GUIDE

---

This guide does not replace the logical equations described previously in this manual, it allows the technician to have a logical step of breakdown service, detailing the successive stages,

The checking of the electric part is carried out in priority because less sensitive to the external parameters than the hydraulics part (temperature, pollution, viscosity...).

The denomination of the movements describes below implies the 2 phases (ex so for the lifting arm: neither raise, nor descent and this of the 2 controls UP/DOWN)

Note: Some options like ASB (Activ Shied Bar) if installed and activated will stop all movements from upper controls only (except turntable rotation) , all movements from lower controls remain active , refer to Haulotte services for more details

### 5.1. NO START

- Battery (GB1)
- Lack of fuel SQ41
- Chain broken SQ12 or/and SQ13
- Emergency stops (SB0, SB1 and SB2)
- Buttons of start-up (SB3/SB4)
- Key selectors (SA0/SA1)
- Fuses FU1, FU4 and FU70
- Relay KMG1
- Relay KA2
- Relay KP1 (start then stop)
- Load alternator
- Module Head node A
- Engine oil pressure B3
- Engine oil temperature B2

### 5.2. NO MOVEMENT

- No pumps
- Fuses FU5, FU6, FU70, FU8 and/or FU10
- Fuse FU16 (for upper control box)
- Relay KMG1/KMG2
- Platform in slope SQ1
- Overload platform (sensors A1, A2, G1 and G2)
- Switch “dead Man” SA19 defective
- Blocked or defective pedals SB6 (upper control box)
- joysticks JYB01 or JYB02 or JYB03 not at the neutral point
- Modules Head nodes A /B1
- Electrovalve YV1

### **5.3. NO DRIVE**

- Key SA1 selector
- Pedals SB6
- Electrovalves YV30A/B
- valve brake release YV12
- joystick JYB01
- Sensor axles outriggers SQ34 /SQ35
- Modules Head nodes A /B1
- No pressure hydrostatic output pump

### **5.4. NO HIGH SPEED**

- Limit switches  
(SQ3L, SQ3H, SQ9, SQ10, SQ11, SQ27, SQ40, SQ42, SQ43, SQ44)
- Electrovalve YV10
- Selector LS/HS drive SWB05
- Modules Head nodes A /B1
- B8 pressure switch

### **5.5. NO LOW SPEED**

- Selector LS/HS drive SWB05
- Drive motors (change of cubic capacity 15/45 cc)
- Modules Head nodes A /B1

### **5.6. NO STEERING ON FRONT AXLE**

- joystick JYB01
- Electrovalves YV21A/B
- Modules Head nodes A /B1

### **5.7. NO STEERING ON REAR AXLE**

- Switch SWB06
- Electrovalves YV22A/B
- Modules Head nodes A /B1

## **5.8. NO EXTENSION OF THE AXLES**

- Key SA1 selector
- Sensors centered turret SQ40-SQ42
- Extension axles SQ30 to SQ33 + SQ34/SQ35/SQ36 and SQ38
- Electrovalve YV8
- Module Head node A
- manual valve lever

## **5.9. NO OSCILLATING LOCK**

- Sensors centered turret SQ40-SQ42
- Limit switches SQ3 L/SQ3H, SQ9, SQ10 ,SQ11, SQ40, SQ42
- Electrovalve YV33
- Modules Head nodes A /B1
- Hydraulics sensor
- Valve of sequence 40b in drive block

## **5.10. NO ARM LIFTING**

- switch bottom panel SA14
- Electrovalves YV3 and YV38 /YV27/YV40
- Selection arm upper controls SWB12
- Sensor detection arm in high position SQ7
- Sensors extension axles SQ30 to SQ33 + SQ34/SQ35/SQ36 and SQ38
- Retraction of telescope SQ10, SL5, SL7, SL8
- joystick JYB02
- Modules Head nodes A /B1
- No pressure

## **5.11. NO ARM TELESCOPING**

- switch bottom panel SA14
- Electrovalves YV6/YV35 /YV36
- Selection arm upper controls SWB12
- Sensors extension axles SQ30 to SQ33 + SQ34/SQ35/SQ36 and SQ38
- joystick JYB02
- Bottom arm with 78° SL5 + SQ7
- Modules Head nodes A /B1
- No pressure



**5.12. NO LINK PART COMPENSATION**

- Electrovalves YV27/YV40
- Sensors SQ27/SL5
- Position pilot valve 7.6b
- Pressure relief valve 70b

**5.13. NO BOOM LIFT**

- switch bottom panel SA13
- Electrovalves YV4+ YV42 (descent)
- Selection arm upper controls SWB12
- Sensors extension axles SQ30 to SQ33 + SQ34/SQ35/SQ36 and SQ38
- joystick JYB03
- Sensors SQ3 L /SQ3H, SL1/SL2, SL3/SL4
- link part compensation shifted (ILS SQ27)
- Modules Head nodes A /B1
- No pressure

**5.14. NO TELESCOPING BOOM**

- switch bottom panel SA8
- Electrovalves YV7/YV41
- Sensors extension axles SQ30 to SQ33 + SQ34/SQ35/SQ36 and SQ38
- joystick JYB02
- If Arm < 78° sensors SQ7/SL1/SL2/SL5
- Modules Head nodes A /B1
- No pressure

**5.15. NO TURRET SLEWING**

- switch bottom panel SA15
- Electrovalves YV5/YV34
- Sensors extension axles SQ30 to SQ33 + SQ34/SQ35/SQ36 and SQ38
- joystick JYB03
- Modules Head nodes A /B1
- No pressure
- Brake release (circuit selector switch)

### 5.16. NO JIB

- switch bottom panel SA6
- Switch top panel SWB11
- Electrovalves YV2B/YV18A-B
- Modules Head nodes A /B1
- No jib pressure

### 5.17. NO ROTATION BASKET

- switch bottom panel SWB13
- Electrovalve YV2B/YV19A-B
- Modules Head nodes A /B1
- Counterbalance valves
- No pressure

### 5.18. NO BASKET COMPENSATION

- Switch bottom panel SA21
- Switch top panel S WB03
- Electrovalves YV2B/YV15A-B
- Modules Head nodes A /B1
- Counterbalance valves 210b
- No pressure

## 6. SUMMARY OF VERSIONS HA41PX

HA41PX		electric	Hydraulic
NT version (> 09-2009) With CAN-BUS and new upper control box + ECU module node B1 + new joysticks (starting from serial number > AD 122738)	All versions	159P319780	159P325420
Version with BPE overload board/joysticks in current 4-20mA + retrofit on outreach transducers + automatic compensation (called kit TN122)	All versions	159P329870	159P328750
Version with BPE overload board /joysticks in current 4-20mA +automatic PL compensation + relay KMG2 only	All versions	159P240710D	159P328750
1st version (< 09-2009) With joystick in current 4-20mA + BPE overload board (normally void as all these models might have been modified according to Technical Note TN122)	All versions	159P240710C	159P252360

## 7. SPECIAL FUNCTIONS

A certain number of movements are prohibited according to the configuration of the machine, in this case, light defect of the top panel lits fixed.

### 7.1. MOVEMENTS WITH AXLES RETRACTED

Only the following movements are possible:

- boom lift if the turret is not aligned (both sides)
- turret slewing if the machine is entirely stowed
- drive

### 7.2. CONDITIONS FOR AXLES EXTENSION

The machine must be entirely stowed (arm, boom, jib, telescope) with the turret aligned.

If a condition is not observed, the buzzer sounds on upper controls (see below the various positions of the sensors)

**Note that the drive remains possible in low/high speed even if axles are in intermediate position (version NT and TN122 depends of software version)**

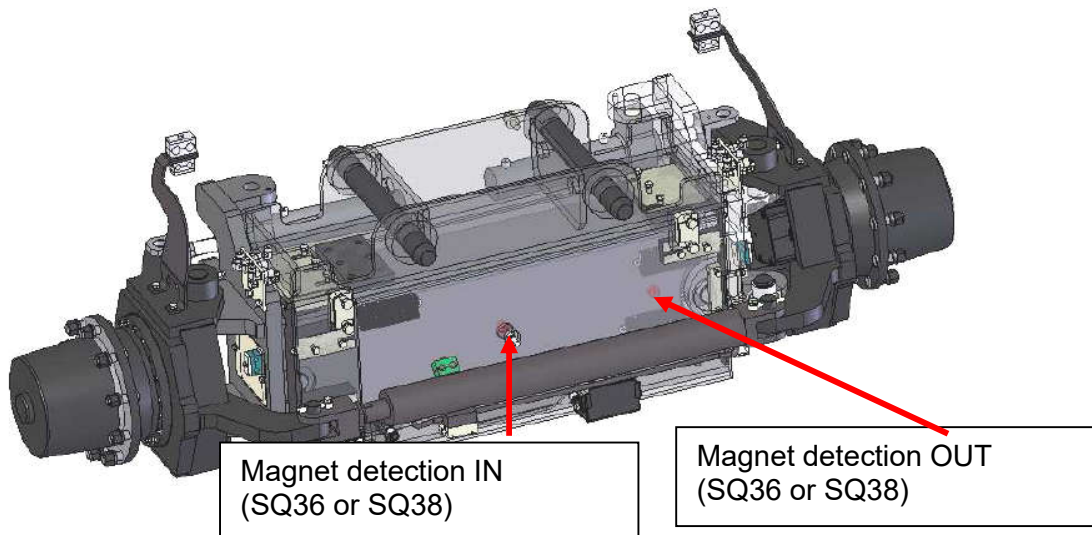

Position front axle	IN	intermediate	OUT
SQ30 (left)	0	-	1
SQ31 (right)	0	-	1
SQ38 (ILS)	1	0	1
Position rear axle	IN	intermediate	OUT
SQ32 (right)	0	-	1
SQ33 (left)	0	-	1
SQ36 (ILS)	1	0	1

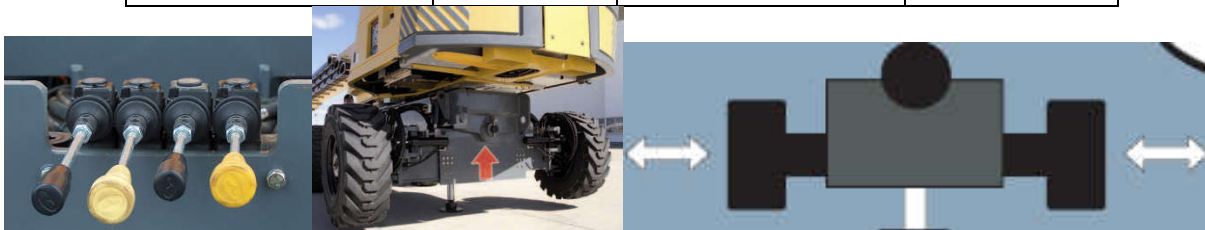



### 7.3. CONDITIONS FOR TELESCOPING ARM EXTENSION

The extension of the telescopic arm are not possible if the arm is not at full stroke (at least  $>75.5^\circ$  detection by sensor SQ7).

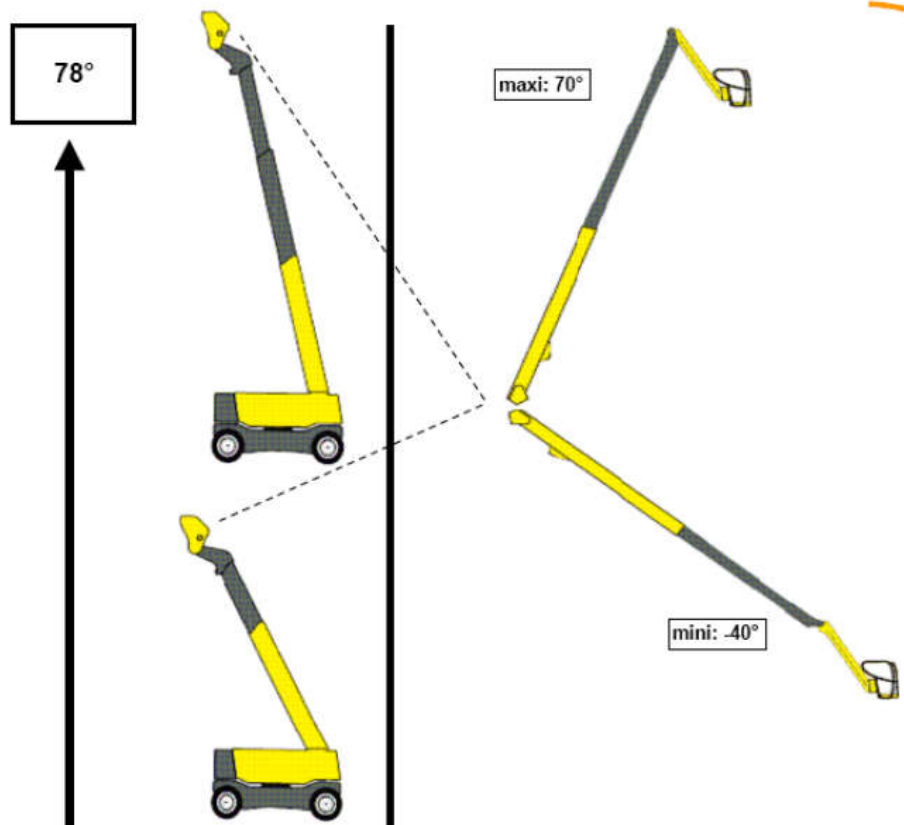

If the arm is not at maxi height ( $78^\circ$ ), the boom lift is limited from  $+0^\circ$  to  $+48^\circ$  only

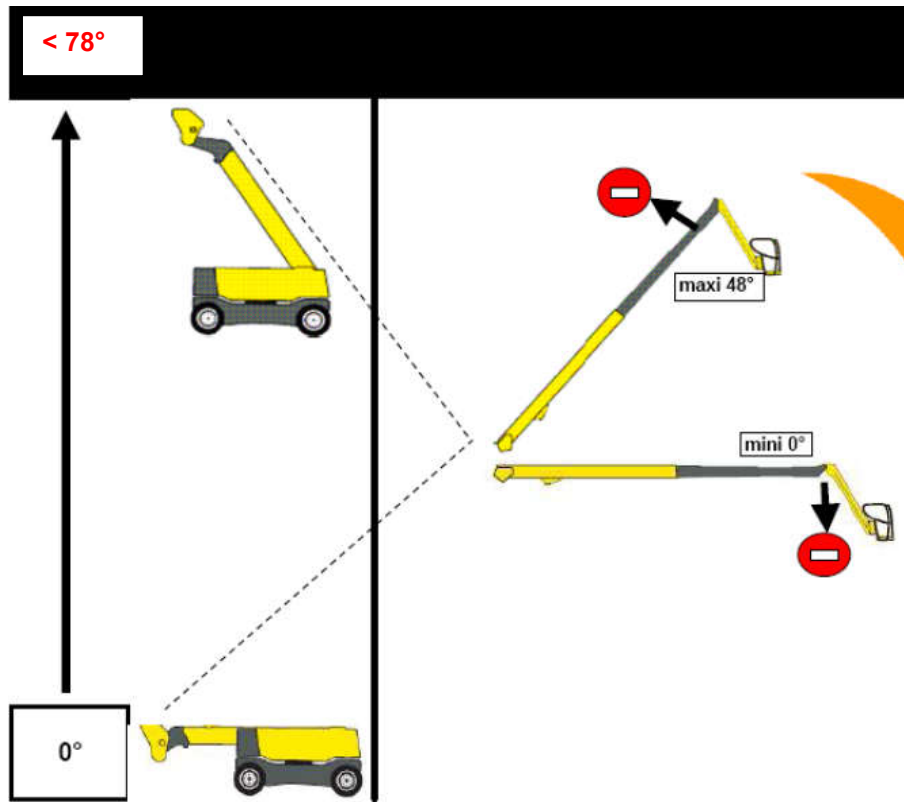

## 7.4. CONDITIONS FOR ARM DESCENT

The descent is possible only if:

- the 2 elements of the telescopic arm are entirely retracted
- the boom is above the horizontal ( $> 5^\circ$  information given by sensor SQ3L)
- the part of compensation is in right and straight position determined by the ILS sensor SQ27

OK

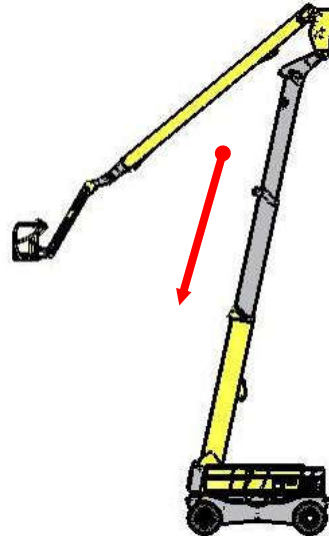
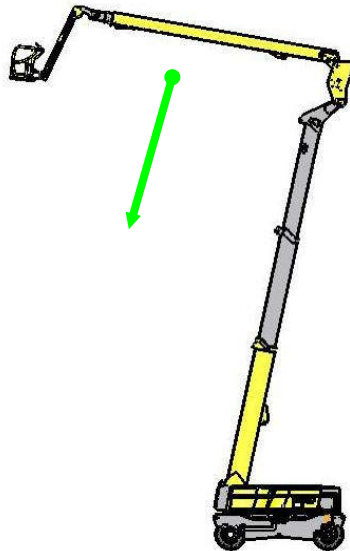

NOK

## 7.5. LINK PART COMPENSATION

### 7.5.1. FUNCTIONAL DESCRIPTION

The lifting of the arm is carried out by a double effect cylinder, a second cylinder ensures the support in its position (link part)

The synchronization of the 2 cylinders is carried out by transfer of volume between the small chamber of the arm lift cylinder and the large chamber of the cylinder of the link part

As the system works in closed loop, the shifting is almost compulsory.

### 7.5.2. CASE OF SHIFTING

Case 1 "rear" shifting



Cases 2 "front" shifting



Case 1 "rear" shifting	Case 2 "front" shifting
Arm stowed with link part shifted detected by magnetic sensor SQ27 Then the link part compensation is done during arm descent by valve YV40	Arm not stowed and link part in correct position then the reset of the arm is done by valve YV27

In all cases, reset of link part is operational during every phase of arm descent and the operator does not have any action particular to carry out



## **7.6. LOAD MANAGEMENT SYSTEM**

This system detects an overlap of nominal load and inform the user that some movements are prohibited.

For that, the jib of the machine which is equipped with a cylinder for double purpose, must be instrumented by 2 angle sensors and of 2 pressure sensors (1 in each chamber of the cylinder)

### **7.6.1. OPERATION**

The system uses four sensors:

- A pressure sensor who measures the pressure in the large chamber of the jib cylinder (G2)
- A pressure sensor who measures the pressure in the small chamber of the jib cylinder (G1)
- A relative angle sensor who measures the angle between the link piece and an arm of jib (A1)
- An absolute angle sensor (or inclinometer) who measures the angle of the link piece compared to gravity (A2)
- The module node B1 specific to model HA41PXNT.

### **7.6.2. PRINCIPLE OF THE LOAD CONTROL**

The ECU in upper controls (module B1 node) compares the current resulting pressure with the maximum pressure authorized in the position given by the relative angle sensor. All this information is transmitted to the main ECU (module node A of the lower control box)

In the event of overlap, the module node A controls the valves and forbidden the movement.

The authorized maximum pressure is determined by a calibration carried out in factory, or during maintenance routine checks.

One jib cycle with slightly raised nominal load carries out.

Several stops are automatically carried out, during which the system records the angle and the static pressure.

The software limits the clearance of jib to its two limits so that the cylinder is never out of mechanical stop

### **7.6.3. ANGLE SENSORS**

#### **Relative angle sensor (A1)**

This potentiometric sensor measures the relative angle of a moving part compared to the structure on which it is fixed,

The pin of output of the potentiometer makes it possible to follow the movement of jib and thus delivers signals according to its position; (it also controls the cut-off High speed drive when the jib exceeds the 3 meters height)

#### **Absolute angle sensor**

Another geometrical parameter has an impact raised on the pressure: the absolute angle (compensation) of jib, therefore the inclination of the basket

The sensor delivers angular information of position between the part holder and an "absolute" reference

This sensor consists of a beam in an oil bath whose position is imposed by gravity, oil has as a function to deaden the movements of the jib.

For this reason, it's a preset correction of the pressure according to the absolute angle.

A mathematical formula corrects the pressure according to the measured angles, to bring back it to a value corresponding to the horizontal basket.

The correction of the absolute angle is limited to a angle range of jib from  $-10^{\circ}$  /  $+10^{\circ}$ .

- **Electric stop**

So that the pressure is representative of embarked load, the jib cylinder should not be out of stop.

For that, the range of the cylinder is limited by 2 electric stops: (UP/DOWN), according to the information transmitted to the module node B then to module node A in lower control box

- **Management of overload system**

A overlap of the nominal load involves:

- The activation of the sound buzzer,
- The activation of lights of overload (LTB06 in basket and HL16 in turret) with alarm (BZB01 in basket and HA4 in turret)
- The forbidden of all the movements from the platform.
- The deceleration of all the movements from the turret.

#### **7.6.4. PROCEDURE OF OVERLOAD CALIBRATION**

**Note:** If any step of the calibration is not correctly respected or continuity not respected, it is necessary to start again the procedure by switching OFF the machine and start the whole procedure.

**Note :** if during the process, a fault comes, an error message will appear and the process must be started again from the beginning

Select menu 2.1 PARAMETERS then 2.6.2 CAL Overload

#### **2.6.2 CAL OVERLOAD**

Put 250 kg (550lbs) in basket and press the "star» button on calibrator

Launch the process by pressing  on Optimizer

if all conditions described above are not correct, the following message will appear.

**ERROR**  
jib learning  
not allowed

If OK ,the process keeps going and the following message will appear:

```
detection
min. jib position
```

- lower the jib and hold the command until this following message.

```
detection
min. jib position
completed
next ?
```

- Then release the command and press  key pad
- Then the following message will appear ,

```
jib up
00000
Angle = 00564
Value = 00000
```

- Lift the jib and hold the command until getting the following message (the jib will lift step by step of 5° until full stroke)

```
jib up
completed
next ?
```

- Release the jib command and press 
- Following message is

```
jib down
```

- Lower the jib and don't release the command until getting the following message :

```
jib down
completed
next ?
```

- release the command and press



Then following message is :

```
data saved
!! stop machine !!
!! and restart !!
```



- Switch OFF and ON again the machine in order to register the calibration
- Remove weight and lift the jib at 20° the lower the jib again in order the electric stop (10mm of the jib rod must be visible when jib is at its lowest position)
- Check and erase the possible Failures in FAILURES menu (OL01 up to OL09)
- END of process

- **Possibles errors code**

Code1	Error in upper detection (position not found).
Code 2	Error in lower detection (position not found).
Code 3	Error during lower position control.
Code 4	Error during load parameters writing in EEPROM (checksum problem), it could be a faulty memory proces in node BN module.
Code 16	Movement stopped during process (generally when the technician releases too early the toggle switch)

### 7.6.5. VALUES OF THE OVERLOAD SENSORS

.	G1	G2	A1	A2
<b>Lowest jib position</b>	3.5 VDC (1340 pts)	0.8 VDC (1660 pts)	9.14 VDC (10310)	7694
<b>Basket at -10°</b>				6.44 VDC
<b>Basket at 0°</b>	1200	1369	7242	6.76 VDC
<b>Basket at + 10°</b>				
<b>Higher jib position</b>	0.8 VDC (560)	3.5 VDC (1263)	3.95 VDC (4703)	7714

## **7.7. SYSTEM OF REACH LIMITATION (HA41PXNT)**

### **7.7.1. PRINCIPLE**

- **Boom**

A sensor (SL3-SL4) equipped with a cable measures a linear drive of the telescope and thus determines its length

A magnetostrictive sensor (SL1-SL2) installed on the rod of one of the boom lift cylinder sends an electric wave along the rod of the cylinder.

it determines the angle of the boom according to its displacement along this rod

An ILS magnet sensor (Blade metal Switch here SQ43) fixed on the telescopic extension allows thanks to the magnets laid out along the telescopic section tube and in redondance with the measurement taken by the sensors boom length SL3 and SL4.

- **Arm**

A sensor (SL7-SL8) equipped with a cable measures a linear drive of the telescope and thus determines its length

1 sensor (SL5) measures the angle of the arm permanently, the redundancy is ensured by a sensor ON/OFF (SQ7) detecting the high position of the arm

2 ILS sensors (here SQ44 and SQ45) fixed each one on one of the telescope section tube allows thanks to the magnets laid out along the telescopic section tube and in redondance of the measurement taken by the boom length sensors SL7 and SL8.

All these informations are transmitted to the main module Head node A.

### 7.7.2. CALIBRATION

This operation is reserved to the technicians belonging to Haulotte Services or technicians who have passed the big Height Booms qualification (superior booms qualification)

During the whole procedure:

- machine is never switched OFF
- engine is always running
- machine is aligned in its axis and not in slope
- chassis extension is extended

Attention, for calibration, the Optimizer calibrator is required and the technician must enter the daily code level 3 .

The right position of all elements of the machine (stowed position and link part in the right position) are essential. if those conditions are not followed , it could result in errors during the measurement of the transducers and then a risk for the stability of the machine.

Note: at each step, the system is analysing the sensors state (time from 2 to 10sec) message displayed is "Checking recording as shown)

Checking Recording..

- Before starting the procedure

the module is in "Calibration" mode:all lights on lower control box are flashing , the buzzer is beeping. if it's not the case , cancel the previous calibration (menu 2.1 PARAMETERS /2.6.1 CALIBRATION Reach limit then /Px: Cancel Reach Lim?) , then switch OFF and ON again the machine.

2.6.1 CAL REACH LIM



Px:Cancel Reach Lim?  
Disable



### Position 1 : Machine in stowed position



P1:Machine stowed ?  
Disable

- Lower the boom until the boom's rest
- Validate the position in PARAMETERS/CALIBRATION/P1: Machine stowed?  
(press the green pad on OPTIMIZER)
  - If OK appears on display, scroll in order to get the following menu.
  - if not OK put the machine in stowed position and adjust the faulty sensor  
(ANA or ON/OFF) and start again the whole process from the beginning.

#### **P1 Expected values**

##### **Sensors Analogic**

SL1 = -  
SL2 = -  
SL3 = 5,71% de Vbat +/- 3,8%  
SL4 = 94,25% de Vbat +/- 3,8%  
SL5 = 2,06V +/- 0,26V [417 +/-53]  
SL7 = 6,40% de Vbat +/- 3,8%  
SL8 = 94,25% de Vbat +/- 3,8%

##### **Sensors ON/OFF**

SQ10 = ON  
SQ9 = ON  
SQ11 = ON  
SQ40 = ON  
SQ42 = ON  
SQ1 = ON  
SQ3H - ON  
SQ3L - ON  
SQ7 - OFF

### Position 2 : Boom at +70°



P2:Boom to 70 deg ?  
Disable

- Lift the boom at its maximum height (+70°).
- Validate the position in PARAMETERS/CALIBRATION/P2: Boom to 70deg ?  
(press the green pad on OPTIMIZER)
- If OK appears on display , scroll in order to get the following menu.
- if not OK put the machine in stowed position and adjust the faulty sensor  
( ANA or ON/OFF) and start again the whole process from the beginning.

#### **P2 Expected values**

##### **Sensors Analogic**

SL1 = 0,98V +/- 0,10V [198 +/- 21]  
SL2 = 4,53V +/- 0,10V [971 +/- 21]  
SL3 =  
SL4 =  
SL5 =  
SL7 =  
SL8 =

##### **Sensors ON/OFF**

SQ10 = ON  
SQ9 = ON  
SQ11 = OFF  
SQ40 = ON  
SQ42 = ON  
SQ1 = ON  
SQ3H = OFF  
SQ3L = ON  
SQ7 = OFF

### Position 3 : Telescopic boom extension fully OUT



```
P3:Teles Boom out ?
Disable
```

Get out the telescopic boom extension at its maximum length

- Validate the position in PARAMETERS/CALIBRATION/P3: Boom teles out ? (press the green pad on OPTIMIZER)
- If OK appears on display, scroll in order to get the following menu.
- if not OK put the machine in stowed position and adjust the faulty sensor ( ANA or ON/OFF) and start again the whole process from the beginning.

#### **P3 Expected values**

##### **Sensors Analogic**

SL1 =  
 SL2 =  
 SL3 = 56,29% de Vbat +/- 3,8%  
 SL4 = 43,15% de Vbat +/- 3,8%  
 SL5 =  
 SL7 =  
 SL8 =

##### **Sensors ON/OFF**

SQ10 = ON  
 SQ9 = OFF  
 SQ11 = OFF  
 SQ40 = ON  
 SQ42 = ON  
 SQ1 = ON  
 SQ3H = OFF  
 SQ3L = ON  
 SQ7 = OFF

### Position 4 : Telescopic boom fully IN



```
P4:Teles Boom in ?
Disable
```

Retract completely the telescopic boom

- Validate the position in PARAMETERS/CALIBRATION/P4: Boom teles in ? (press the green pad on OPTIMIZER)
- If OK appears on display , scroll in order to get the following menu.
- if not OK put the machine in stowed position and adjust the faulty sensor ( ANA or ON/OFF) and start again the whole process from the beginning.

#### **P4 Expected values**

##### **Sensors Analogic**

SL1 =  
 SL2 =  
 SL3 =  
 SL4 =  
 SL5 =  
 SL7 =  
 SL8 =

##### **Sensors ON/OFF**

SQ10 = ON  
 SQ9 = ON  
 SQ11 = OFF  
 SQ40 = ON  
 SQ42 = ON  
 SQ1 = ON  
 SQ3H = OFF  
 SQ3L = ON  
 SQ7 = OFF

**Position 5 : Boom at 0°**



P5:Boom to 0 deg ?  
Disable

- Lower the main boom until the boom's rest
- Validate the position in PARAMETERS/CALIBRATION/P5: Boom to 0deg ? (press the green pad on OPTIMIZER)
  - If OK appears on display, scroll in order to get the following menu.
  - if not OK put the machine in stowed position and adjust the faulty sensor
  - ( ANA or ON/OFF) and start again the whole process from the beginning.

**P5 Expected values**

**Sensors Analogic**

SL1 =  
SL2 =  
SL3 =  
SL4 =  
SL5 =  
SL7 =  
SL8 =

**Sensors ON/OFF**

SQ10 = ON  
SQ9 = ON  
SQ11 = ON  
SQ40 = ON  
SQ42 = ON  
SQ1 = ON  
SQ3H = ON  
SQ3L = ON  
SQ7 = OFF

**Position 6 : Arm at 78°**

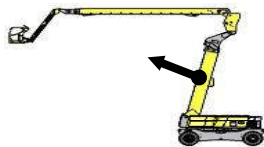

P6:Arm to 78 deg ?  
Disable

- Lift the primary boom at its maximum position (78°)
- Validate the position in PARAMETERS/CALIBRATION/P6: Arm to 78deg ? (press the green pad on OPTIMIZER)
- If OK appears on display, scroll in order to get the following menu. if not OK put the machine in stowed position and adjust the faulty sensor ( ANA or ON/OFF) and start again the whole process from the beginning.

**P6 Expected values**

**Sensors Analogic**

SL1 =  
SL2 =  
SL3 =  
SL4 =  
SL5 = 4,60V +/- 0,26V [933 +/- 53]  
SL7 =  
SL8 =

**Sensors ON/OFF**

SQ10 = ON  
SQ9 = ON  
SQ11 = OFF  
SQ40 = ON  
SQ42 = ON  
SQ1 = ON  
SQ3H = ON  
SQ3L = ON  
SQ7 = ON



### Position 7 : Telescopic arm extension fully OUT

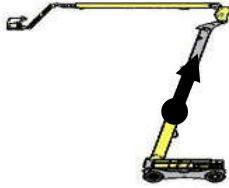

P7:Teles Arm out ?  
Disable

get out both telescopic arm extension at their maximum length

- Validate the position in PARAMETERS/CALIBRATION/P7: Arm teles out ?

(press the green pad on OPTIMIZER)

- If OK appears on display, scroll in order to get the following menu.
- if not OK put the machine in stowed position and adjust the faulty sensor
- ( ANA or ON/OFF) and start again the whole process from the beginning.

#### **P7 Expected values**

##### **Sensors Analogic**

SL1 =  
SL2 =  
SL3 =  
SL4 =  
SL5 = 4,60V +/- 0,26V [933 +/- 53]  
SL7 =  
SL8 =

##### **Sensors ON/OFF**

SQ10 = ON  
SQ9 = ON  
SQ11 = OFF  
SQ40 = ON  
SQ42 = ON  
SQ1 = ON  
SQ3H = ON  
SQ3L = ON  
SQ7 = ON

### Position 8 : Boom at - 40°



P8:Boom to -40 deg ?  
Disable

- Lower the main boom at its lowest position (- 40°)

- Validate the position in PARAMETERS/CALIBRATION/P8: Boom to -40deg?

(press the green pad on OPTIMIZER)

- If OK appears on display, scroll in order to get the following menu.
- if not OK put the machine in stowed position and adjust the faulty sensor
- ( ANA or ON/OFF) and start again the whole process from the beginning.

#### **P8 Expected values**

##### **Sensors Analogic**

SL1 = 4,82V +/-0,10V [977 +/- 21]  
SL2 = 0,95V +/- 0,10V [193 +/- 21]  
SL3 =  
SL4 =  
SL5 =  
SL7 =  
SL8 =

##### **Sensors ON/OFF**

SQ10 = ON  
SQ9 = ON  
SQ11 = OFF  
SQ40 = ON  
SQ42 = ON  
SQ1 = ON  
SQ3H = ON  
SQ3L = ON  
SQ7 = ON

**Position 9 : Boom at +5°**

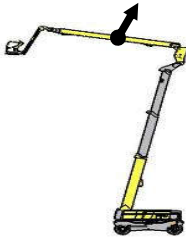

```
P9:Boom to 5 deg  ?
Disable
```

lift the main boom until it stops (+ 5°)

- Validate the position in PARAMETERS/CALIBRATION/P9: Boom to +5deg ?  
(press the green pad on OPTIMIZER)

- If OK appears on display, scroll in order to get the following menu.
- if not OK put the machine in stowed position and adjust the faulty sensor
- ( ANA or ON/OFF) and start again the whole process from the beginning.

**P9 Expected values**

**Sensors Analogic**

SL1 =  
SL2 =  
SL3 =  
SL4 =  
SL5 =  
SL7 =  
SL8 =

**Sensors ON/OFF**

SQ10 = OFF  
SQ9 = ON  
SQ11 = OFF  
SQ40 = ON  
SQ42 = ON  
SQ1 = ON  
SQ3H = ON  
SQ3L = ON  
SQ7 = ON

**Position 10 : Arm at 0°**



```
P10:Arm to 0 deg ?
Disable
```

Lower completely the primary boom (until its rest's position)

- Validate the position in PARAMETERS/CALIBRATION/P10: Arm to 0deg ? (press the green pad on OPTIMIZER)
  - If OK appears on display, scroll in order to get the following menu.
  - if not OK put the machine in stowed position and adjust the faulty sensor ( ANA or ON/OFF) and start again the whole process from the beginning.

**P10 Expected values**

**Sensors Analogic**

SL1 =  
SL2 =  
SL3 =  
SL4 =  
SL5 =  
SL7 =  
SL8 =

**Sensors ON/OFF**

SQ10 = ON  
SQ9 = ON  
SQ11 = OFF  
SQ40 = ON  
SQ42 = ON  
SQ1 = ON  
SQ3H = ON  
SQ3L = ON  
SQ7 = OFF

**Position 11 : Boom at 0°**



```
P11:Boom to 0 deg ?
Disable
```

Lower completely the main boom ( until its rest's position)

- Validate the position in PARAMETERS/CALIBRATION /P110 Boom to 0deg? (press the green pad on OPTIMIZER)
  - If OK appears on display, the calibration is done, the turret lights stop flashing, the buzzer stops beeping.
- if not adjust or replace the faulty sensor (ANA or ON:OFF) and start again the whole process from the beginning.

**P11 Expected values**

**Sensors Analogic**

SL1 =  
SL2 =  
SL3 =  
SL4 =  
SL5 =  
SL7 =  
SL8 =

**Sensors ON/OFF**

SQ10 = ON  
SQ9 = ON  
SQ11 = ON  
SQ40 = ON  
SQ42 = ON  
SQ1 = ON  
SQ3H = ON  
SQ3L = ON  
SQ7 = OFF



Check that the calibration process is over: the turret lights are not flashing and the buzzer in turret is not beeping, if not go in menu FAILURES in order to find the problem.

Control Process in order to check the quality of the sensors' adjustment:

Reset all defaults "Times" in menu 6.FAILURES

Validate in 2.4 MAINTENANCE/ Option "Factory tolerances".

Once activated, this option will reduce the tolerances on the faults' detection.

( it will automatically disactivated when machine is switched OFF).

Proceed to a complete cycle :

Machine in stowed position.

- Lift the arm at 78° , then take out both telescopic arms.
- Lift the main boom at 70°.
- Take out the telescopic boom extension.

lower the main boom at - 40° (the telescopic boom should retract by itself when reaching the limit of the working zone)

- put back the machine in stowed position.
- if some failures appear during this cycle , check the mounting of the concerned sensors ( gap, connection..) and solve the problem

### 7.7.3. NORMAL INDICATIVE VALUES OF THE SENSORS

#### 7.7.3.1. Value angle sensor arm (tolerance + 10%)

	SL5 (wire 611B)	Points console
Arm at 0° (mini SL5)	2.06 VDC (8.64 my)	417 + 53
Arm at 78° (SL5 max)	4.60 VDC (19.32mA)	933 + 53

#### 7.7.3.2. Value angle sensor boom (tolerance + 0.10VDC)

	SL1 (wire 418)	SL2 (wire 419)
Boom at - 40° (mini SL1)	4.82VDC (977 pts+/- 21)	0.95 VDC (193+/-21pts)
Boom at 0°	3.35 V (680 pts +/- 21)	2.20 V (446 +/- 21pts)
Boom at +70° (SL1 max)	0.98 VDC (198+/- 21pts)	4.53 VDC (971+/- 21pts)

#### 7.7.3.3. Value sensor length arm (+ 3.8%)

	SL7 (wire 259)	SL8 (wire 901)
Retraction telescope (mini SL7/8)	6.40% of Vbat (74 pts)	94.28% of Vbat (1090pts)
extension telescope (SL7/8 max)	72.29% of Vbat (836 pts)	28.53% of Vbat (330 pts)

#### 7.7.3.4. Value sensor length boom (+ 3.8%)

	SL3 (wire B308)	SL4 (wire B309)
Retraction telescope (SL3/4 mini)	5.71% of Vbat (66 pts)	94.23% of Vbat (1090pts)
extension telescope (SL3/4 maxi)	56.29% of Vbat (651 pts)	43.15% of Vbat (499 pts)

## 7.8. SENSORS ADJUSTMENT

### 7.8.1. ANGLE TRANSDUCERS

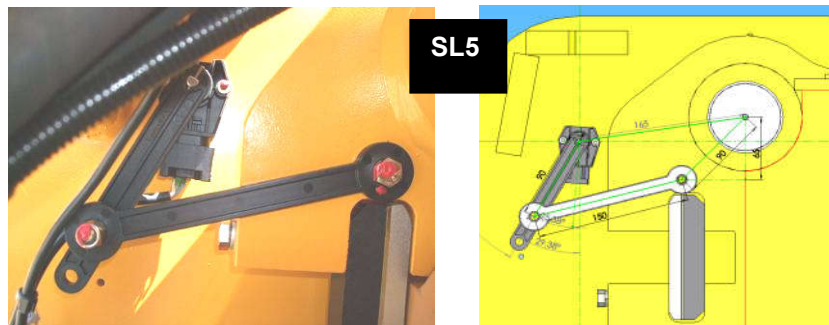

#### For SL5

Install the rod on angle transducer (be careful to turn the flat surface towards the sensor)

- install the 150mm rod as shown above
- Connect the sensor and pre-check the value with the Optimizer calibrator (refer values on previous table)
- Tight the whole system and check if the sensors value didn't move, otherwise readjust if necessary.

Magnetostrictive sensor SL1/SL2 fitted inside one of the boom lifting cylinder (normally on left side)  
no specific requirement



### 7.8.2. LENGTH TRANSDUCERS



- Remove the safety rope
- Fix the reel on its support for boom or directly on the machine for the arm
- Attach the carabineer of the nylon rope at the back side of the telescopic extension

### 7.8.3. MAGNETIC SENSORS (ILS TYPE) AND MAGNET POSITION

The assembly instruction is shown below however it's remains the same for all: models equipped with ILS\* sensors

\* ILS : Interrupteur Lame Souple (Reed effect sensor)

However the calculation of the zones has been changed as an additional magnet is now installed in front of the ILS sensor SQ43 and SQ44 when telescopic are fully retracted (so there is one more magnet on the 1<sup>st</sup> telescopic extension for arm and one for boom).

The 1<sup>st</sup> telescopic detection (zone 0) arm/boom when fully IN (< 200mm) is OK

if  $SQ10/SQ9 = 1 + SQ44/SQ43 = 1 + SL3/SL4$  (value at 0.9VDC)

Fit the sensor so as the distance between magnets and sensor will be ideally between 6 and 15mm

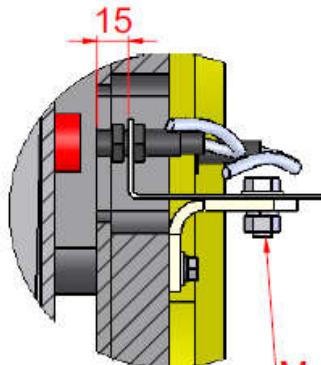

- SQ3L/SQ3H ADJUSTMENT (boom angle detection)

ANGLE	SQ3L	SQ3H
< 0°	0	1
> 0°	1	1
> 50°	1	0

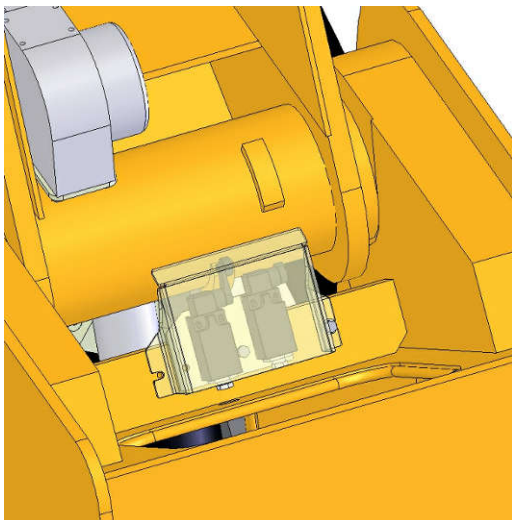

SQ3L and SQ3H = 1 arm descent authorisation

If boom > 50° (SQ3H = 0): arm descent is not possible (telescopic boom/arm retraction remains possible)

(Outreach limitation orange lits ON fixed)

### 7.8.4. HOW TO UNDERSTAND THE SENSORS READING IN POINTS

When connecting the OPTIMIZER console, the values of the sensors are sometimes in points

see below the explanation for the sensors supplied in 4-20mA

Checking/adjusting SL1 & SL2 values.

- Values are displayed in Bit (0 – 1023)
- Bit values are calculated from Amperage-

$$\text{Bit} = (\text{mA}) \times (1023 / 21.23)$$

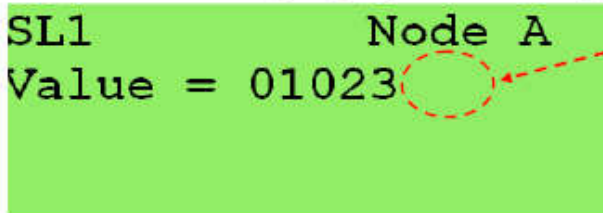

When no unit of measurement is listed on the screen, it safe to assume the value is in bit

So, to use the example of SL1 boom to 0°, we can check the Bit value

$$\text{Bit} = (\text{mA}) \times (1023 / 21.23)$$

$$\text{Bit} = 18.1 \times 48.1856$$

$$\text{Bit} = 872$$

	SL1 ( Wire 611B)			SL2 ( Wire 805)		
	Voltage	Current	Bit	Voltage	Current	Bit
Boom to 0°	4.22 V	18.1mA	872	1.56 V	6.31 mA	304
Boom to 75°	1.54V	6.85mA	330	4.19 V	17.45mA	840



## 8. CALIBRATION PROCESS WITH HAULOTTE DIAG

### 8.1. LOAD

The procedure is the same when using the OPTIMIZER console, however the messages might be different as shown below

Put nominal load on basket, then enter in calibration menu in level 2 code (2031)

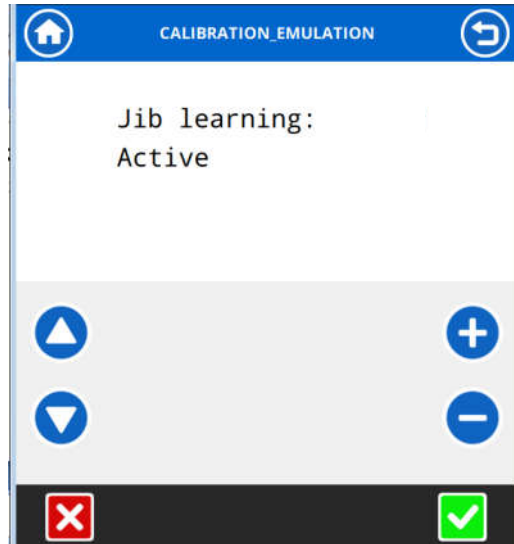
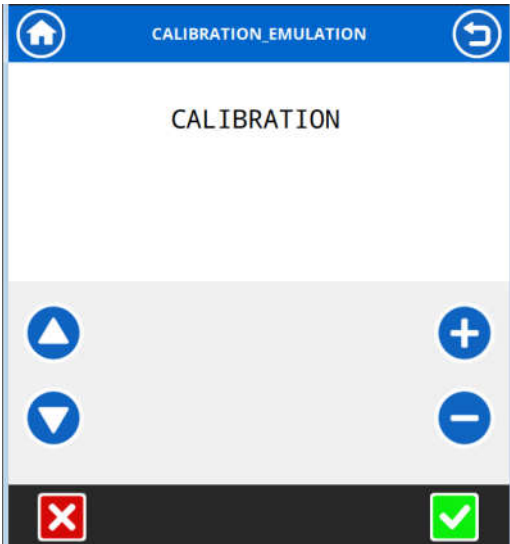

Next step

(Never the release the command until the message will tell you to do it)

if so the error 16 will appear on screen and you have to restart the whole procedure from beginning

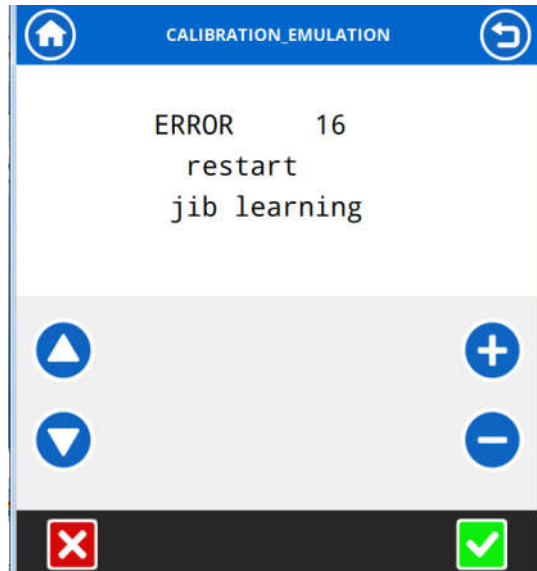
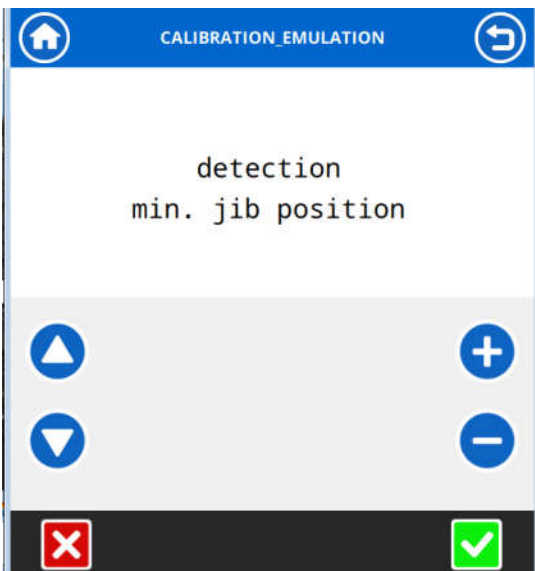

From LCB , use toggle switch and lower the jib in lowest position when it's completed , lift the jib

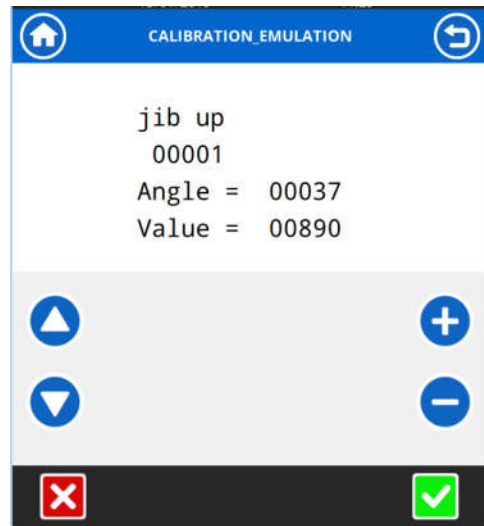

The jib will lift by step of 5° each until reaching the highest position (0° to 120° approximatively)

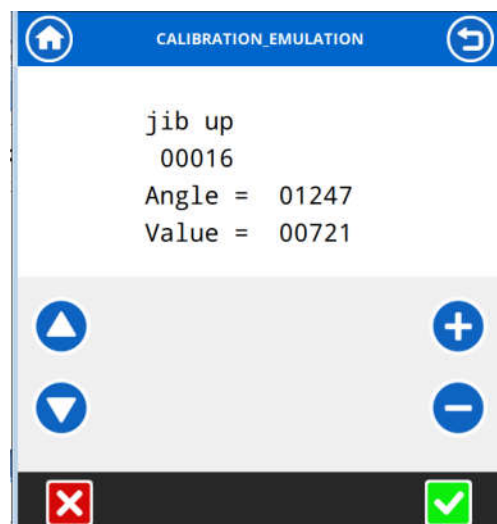
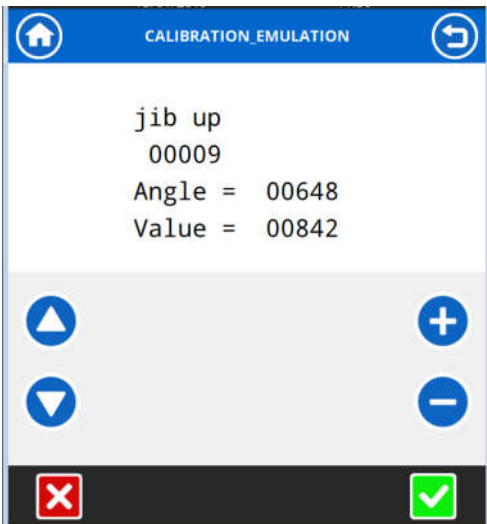

Next

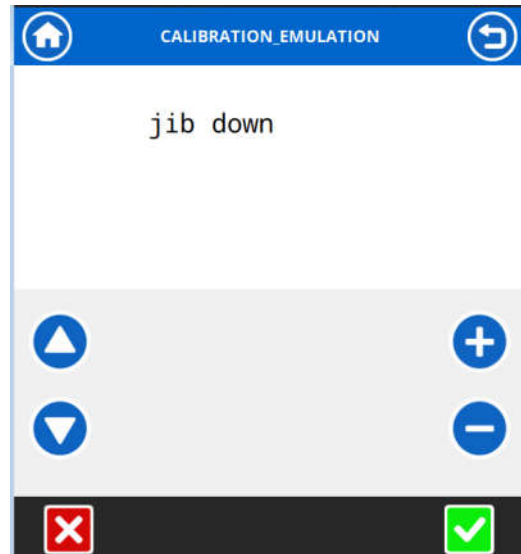
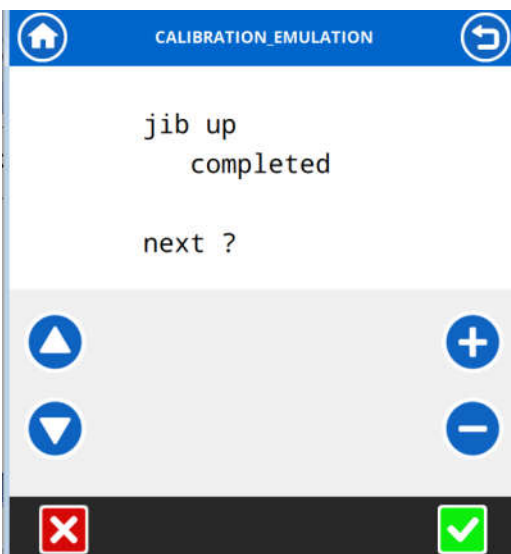

Final message



## 8.2. REACH LIMIT

The procedure is the same when using the OPTIMIZER console, however the messages might be different as shown below

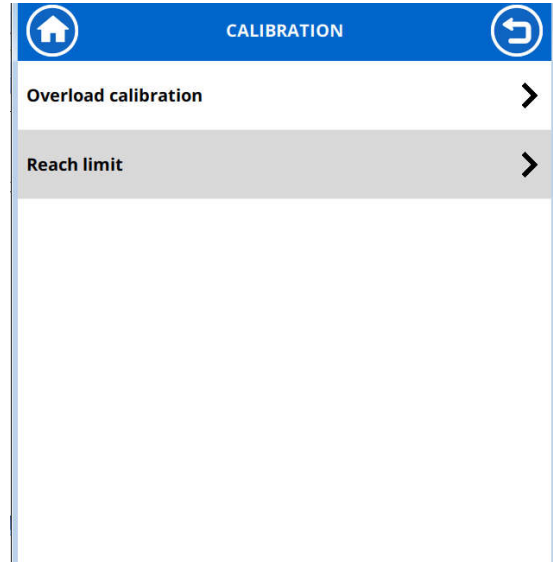
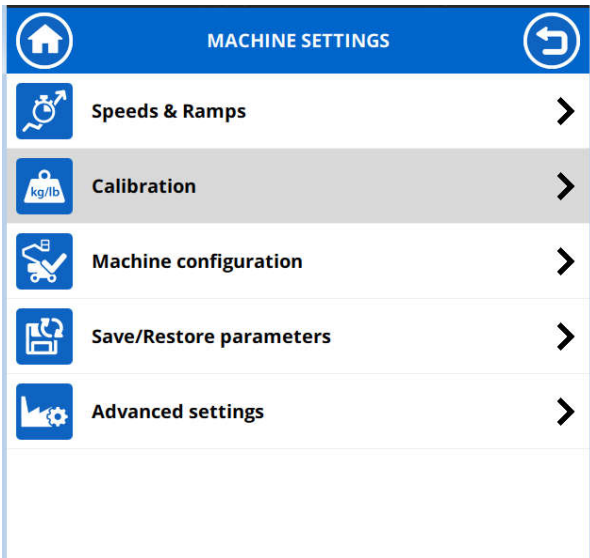

Next (level 3 code is required)

Cancel the previous calibration and follow steps as described (from P1 to P11)

**Never the release the command until the message will tell you to do it**

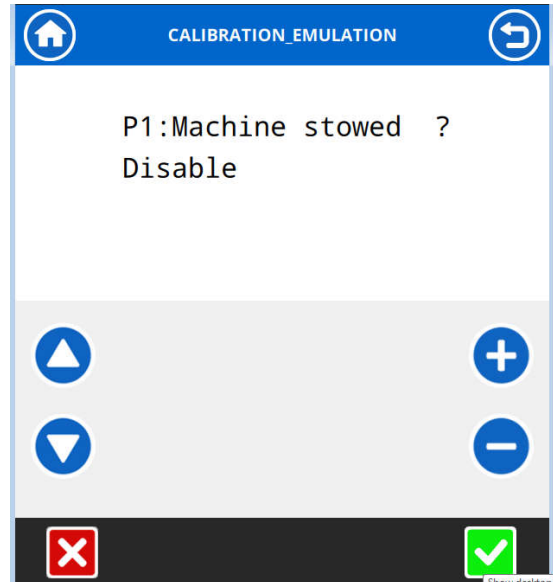
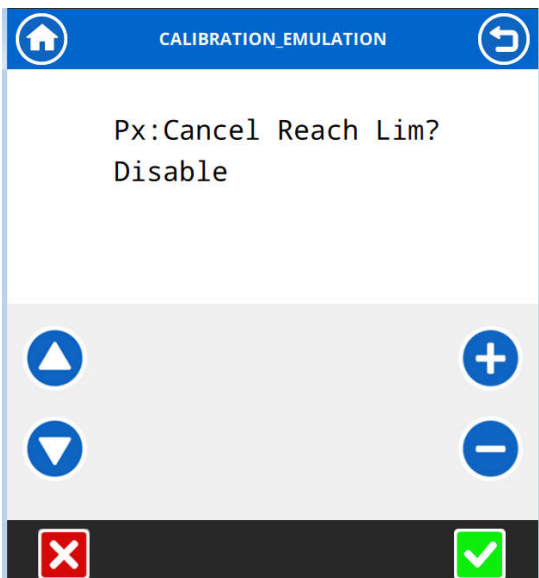



Next step

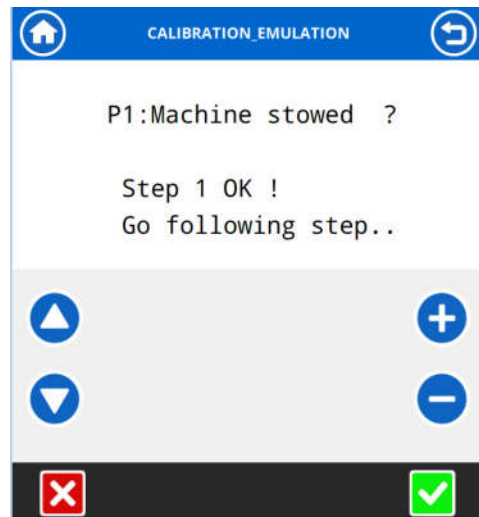
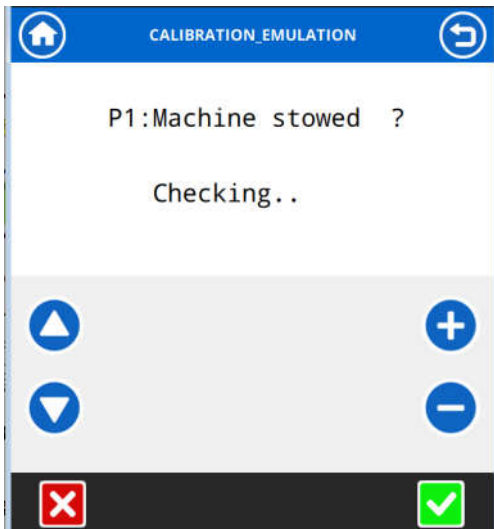

Next step

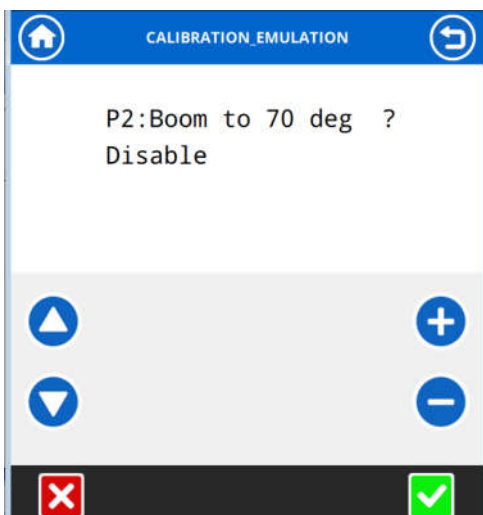

Next step



Next step



Next step

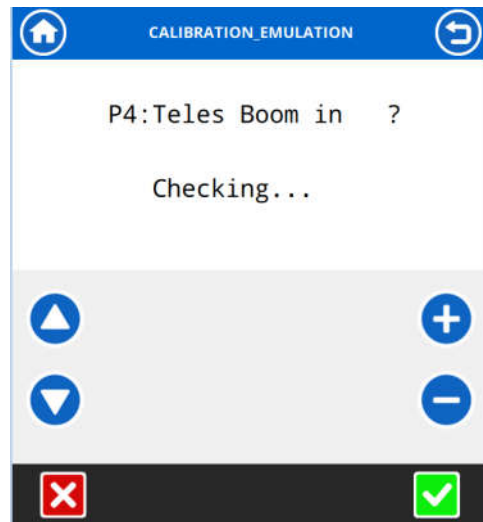
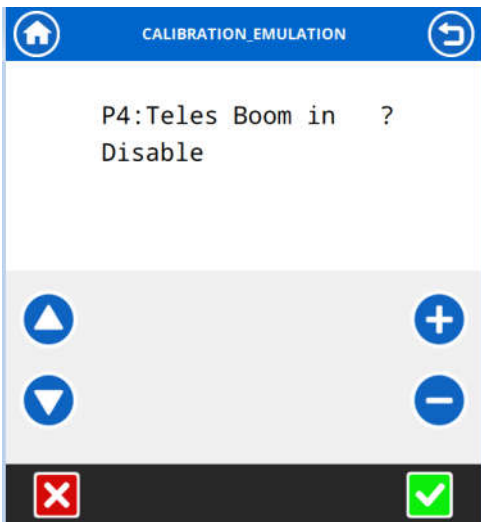

Next step



Next step



Next step

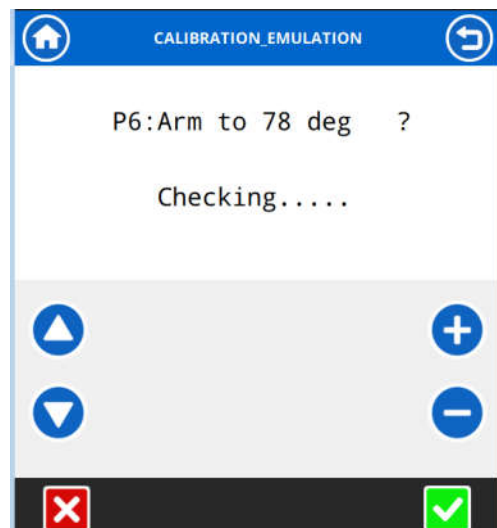

Next step

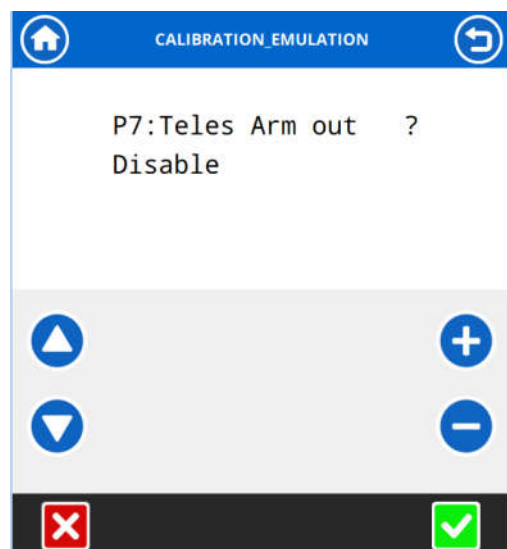

Next step



Next step

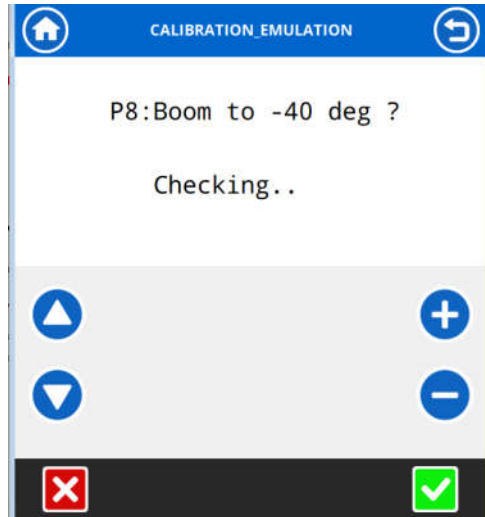
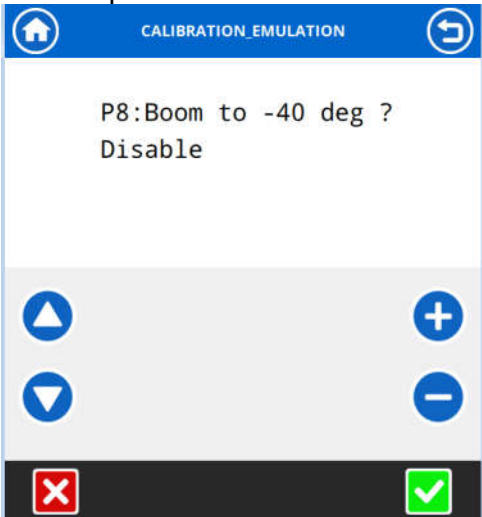

Next step

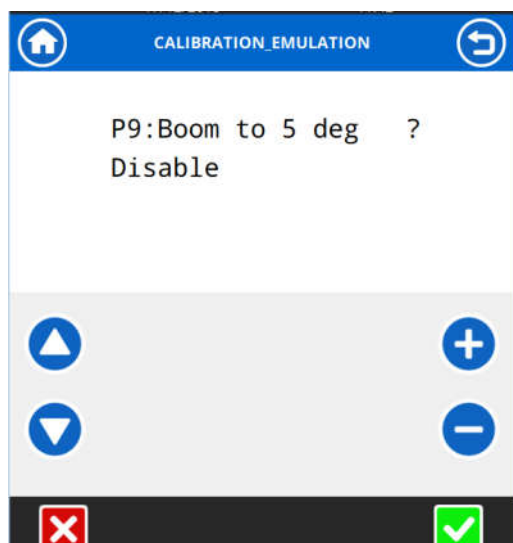



Next step

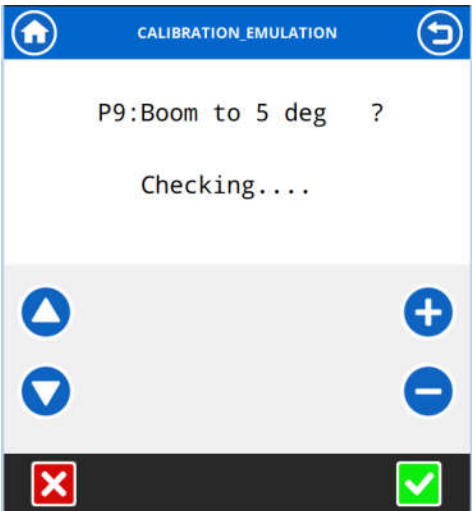

Next step

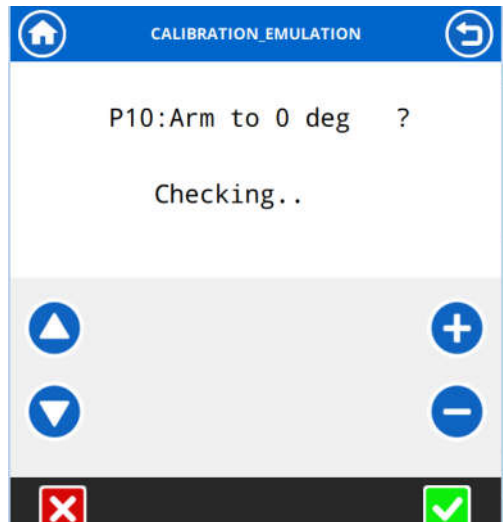

Next step



Next step

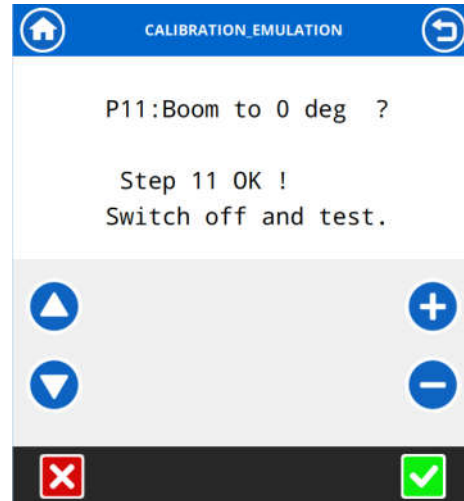

Go in advanced setting to activate Factory settings

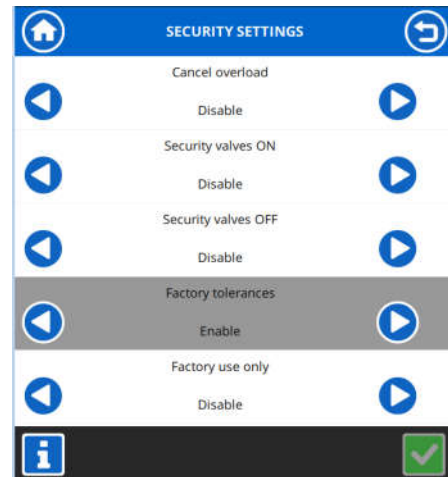
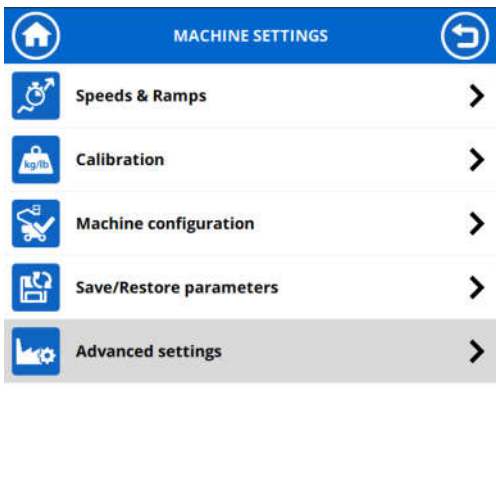

Perform all movement then check there is no alarm and any transducer OK

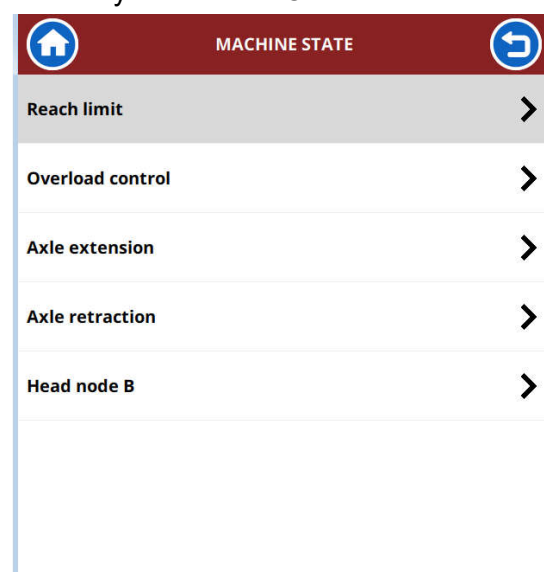
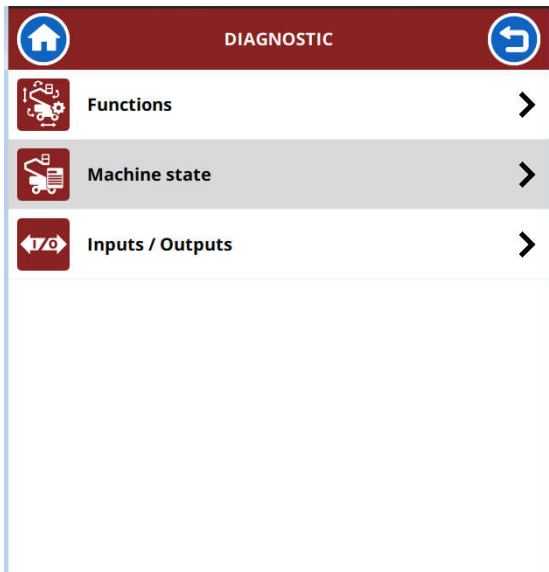

Check that every is OK as shown below

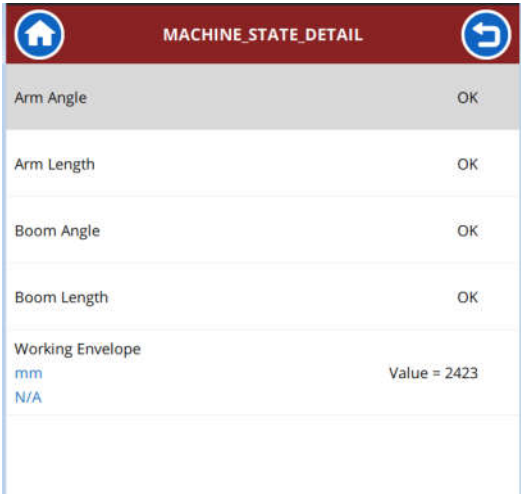

MACHINE_STATE_DETAIL	
Arm Angle	OK
Arm Length	OK
Boom Angle	OK
Boom Length	OK
Working Envelope	
mm	Value = 2423
N/A	

## 9. MACHINES EQUIPPED WITH KIT TN122

---

### 9.1. EXPLANATION

These machines are a mix between the 1st version and the NT

All The 1<sup>st</sup> version of HA41PX should normally be upgraded

All informations regarding the technical upgrade between these machines are explained in the TN122 available to your nearest HAULOTTE Services

The biggest modifications are

- Automatic compensation of the link part done by YV27/YV40
- Outreach limitation sensors SL1-SL2 are included in the left boom lifting cylinder (magnetostrictive sensor)
- the arm angle sensor SL5 detects the low position and the higher position is done by an ON/OFF sensor SQ7
- Boom angle detection done by 2 limit switches SQ3L (low and negative boom position) and SQ3H (high position)
- Start/stop engine done by the toggle switch (the E-stop remains for emergency stop only)
- For the calibrations, the outreach calibration is the same as for NT version
- The overload calibration remains the same as before (BPE calibration, refer instructions as shown below)
- The parameters menu is different (list not available on this manual)
- See on next pages the new schematics (hydraulic + electric called TN122)



## 9.2. SPECIFIC DATAS

On these models, there is 3 specific joysticks supplied in 4-20mA current, as the inputs on Head are in voltage, there is a resistance located in lower control box  
Value of resistance is  $470\Omega$   $\frac{1}{4}$  W (2901014520)

The joysticks 'signal is slightly different from the others models in voltage

Min Position	Neutral position	Maxi Position
4mA	12 mA	20 mA
0.63 VDC	1.9 VDC	3.16 VDC
125 points*	380 points*	645 points*

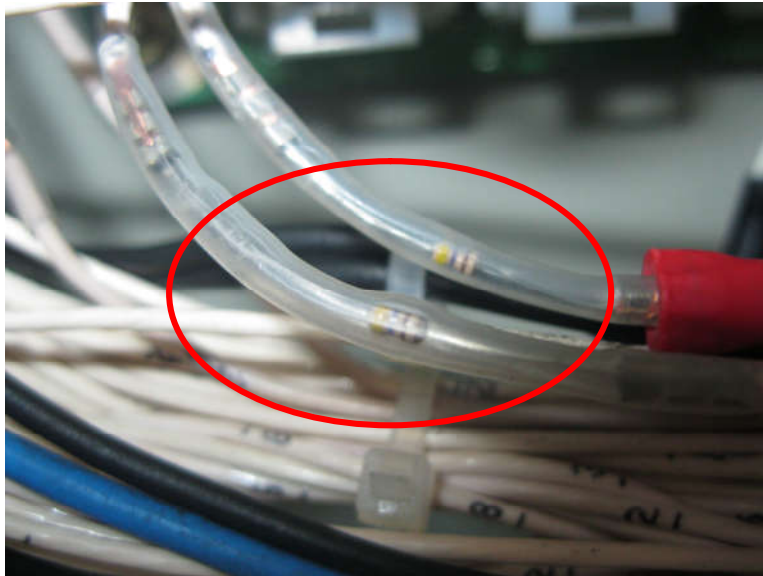

Same reason for the analogic sensors (SL1/SL2/SL5),  
The value of the resistances is more precise  $301\Omega$   $\frac{1}{4}$ W 0.1% (4000201370)



### 9.3. LIST OF PARAMETERS

Menu 2. PARAMETERS			
2.1 SPEEDS	P. Jib Up		+/- for modification (0 à 100%)
	P. Jib Down		
	P. Plat Rotate		
	P. Plat Level		
	P. Arm Down		
	P. Arm Up		
	P. Boom Down		
	P. Boom Up		
	P. Turret Right		
	P. Turret Left		
	P. Arm Ext. In		
	P. Arm Ext. Out		
	P. Boom Ext. In		
	P. Boom Ext. Out		
	P. Trans Fwd		
P. Trans Rev			
2.2 RAMPS	ACC Jib Up		+/- for modification (1 to 50)
	DEC Jib Up		
	ACC Jib Down		
	DEC Jib Down		
	ACC Plat. Rot.		
	DEC Plat. Rot.		
	ACC Plat. Level		
	DEC Plat. Level		
	ACC Arm Up		
	DEC Arm Up		
	ACC Arm Down		
	DEC Arm Down		
	ACC Boom Up		
	DEC Boom Up		
	ACC Boom Down		
	DEC Boom Down		
	ACC Turret Right		
	DEC Turret Right		
	ACC Turret Left		
	DEC Turret Left		
ACC Boom Ext. In			

	DEC Boom Ext. In		
	ACC Boom Ext. Out		
	DEC Boom Ext. Out		
	ACC Arm Ext. In		
	DEC Arm Ext. In		
	ACC Arm Ext. Out		
	DEC Arm Ext. Out		
2.3 OPTIONS	Transla. Buzzer	Activation of buzzer for drive mode	+/- for modification (Active ou Inactive)
	Movement buzzer	Activation of buzzer for movement	
	European mode	Standard mode (EN280 norms)	
	Austral. Mode	Australian (AS norms)	
	USA mode	US mode (ANSI norms)	
	Manual Preheat	Manual Preheating	
2.4 MAINTENANCE	Cancel Overload	Cancel the overload calibration mode	
	All secu valves ON	Command all the following safety valves YV41, YV42, YV34, YV38, YV35 and YV36.	Permit in static mode to check if there is no leak through these distributors and associated counterbalances valves.
	All secu valves OFF	Forbid the command on the following safety valves YV41, YV42, YV34, YV38, YV35 and YV36.	Permit in dynamic mode if safety valves are working well by asking a movement ; it must not be active.
	Factory tolerances	Reduce from 30% the tolerances on faults detection	Permit to check the accuracy of the transducers .
	! Only for factory !	Cancel some securities on machine	!!! not be used
2.5 FACTORY SETTINGS Accessible with code level 2 or 3	Factory Settings ?	Back to factory original values (ramps, speeds, options)	* for validation
2.6.1 CALIBRATION Reach limit Accessible only with level 3 daily code	Px : Cancel Reach lim?	Reset calibration.	+/- for cancelling
	P1 : Machine stowed ?	1 <sup>st</sup> point of calibration: Machine is stowed position.	
	P2 : Boom to 70° ?	2 <sup>nd</sup> point of calibration: Boom full up.	

	P3 : Teles boom out ?	3 <sup>rd</sup> point of calibration : telescopic boom fully extended	+/- for validate each step
	P4 : Boom tele in ?	4 <sup>th</sup> point of calibration: telescopic boom fully retracted.	
	P5 : Boom to 0° ?	5 <sup>th</sup> point of calibration: boom on turret.	
	P6 : Arm to 78° ?	6 <sup>th</sup> point of calibration: Arm full up.	
	P7 : Teles Arm in ?	7 <sup>th</sup> point of calibration: both telescopic arm fully extended.	
	P8 : Boom to - 40°?	8 <sup>th</sup> point of calibration: boom in negative position.	
	P9 : Boom to + 5° ?	9 <sup>th</sup> point of calibration: boom above horizontal angle (automatic stop at 5°).	
	P10 : Arm to 0° ?	10 <sup>th</sup> point of calibration: arm in stowed position.	
	P11 : Boom to 0° ?	11 <sup>th</sup> point of calibration: boom in stowed position.	
	2.6.2 Cal Overload Accessible with code level 2 (or 3)	Start jib learning ?	
2.7 SERIAL NUMBER Accessible with daily code level 3)	ADxxxxxx	Serial number of the machine.	+/- for modification

### Menu 3. INPUTS - OUTPUTS

<b>DIGITAL INPUTS</b>	SQ2	Detection of jib position	"ON" if jib in full down
	SM31HN	Neutral position of the orientation/lift joystick	"ON" if joystick not in the axis (axis X or Y)
	SA13U	Boom lift	"ON" if toggle switch pushed
	SA13D	Boom descent	"ON" if toggle switch pushed
	SM2HN	Neutral position of the arm joystick	"ON" if joystick not in axis
	SA14U	Arm lift	"ON" if toggle switch pushed
	SA14D	Arm descent	"ON" if toggle switch pushed
	SB6	Foot switch (pedal)	"ON"=if pedal pushed
	SA15L	Left turret rotation	"ON" if toggle switch pushed
	SA15R	Right turret rotation	"ON" if toggle switch pushed
	BPE J4.5	BPE board : overload signal	"ON"=overload
	DPlus	Signal on alternator	"ON"=engine running
	KMG1	relay KMG1 survey	"ON"=key switch at power ON and E-stop not pushed
	B8	Pressure switch for high speed detection	"ON"= high speed drive in process and machine not in stowed position



	SQ40	Detection turret position (limit switch )	"ON"= if turret aligned
	SQ11	Detection boom in stowed position	"ON"= boom and arm in stowed position
	SB3	Engine start/stop	"ON"= push in order to start the engine ( a 2 <sup>nd</sup> push will stop the engine)
	SQ7	Detection arm in upper position	"ON"=arm in upper position (>73°)
	SA2	Accelerator	"ON"= push in order to have the full engine rpm (~2400rpm)
	SQ42	Detection turret position (ILS : magnet switch)	"ON"= if turret aligned
	SQ43	Detection of magnets along the telescopic boom section	"ON"=sensor capteur en face d'un magnet du télescope flèche (10 magnets)
	SQ9	Detection of telescopic boom position	"ON"= if telescopic boom retracted
	SQ35	Detection of rear stabiliser	"ON"=if rear stabiliser is retracted
	SQ12	Detection of chain breadown ( boom foot)	"OFF"=chain broken
	SA18	Generator ( only upper controls)	"ON"= if toggle switch pushed
	SA3	Diferential lock	"ON"=if toggle switch pushed
	SQ45	Detection of magnet position along the 2 <sup>nd</sup> telescopic arm section	"ON"=capteur en face d'un magnet du télescope bras 2e fût (5 magnets)
	SA9	Selection toggle switch arm/telescopic boom	"ON"= if arm selected / "OFF" if boom selected
	SQ1	Slope sensor	"OFF"= slope sensor activated
	B4	Pressure switch detection hydraulic oil overheating	"OFF"=if hydraulic oil overheated
	SQ44	Detection of magnet position along the 1st arm telescopic extension	"ON"=capteur en face d'un magnet du télescope bras 1er fût (5 magnets)
	SQ34	Detection of front stabiliser	"ON"= if front stabiliser retracted
	SA5_SA21_U	Basket compensation ( up)	"ON"= if toogle switch pushed
	SA4L	Left basket rotation	" ON"= if toogle switch pushed
	BPE_J4.3	BPE board : signal of upper position of the jib	"ON"= if in upper detection detected
	SA12R	Rear right steering	"ON"= if toogle switch pushed
	SA11	High speed selection switch	"ON"=if high speed is selected
	SM4HN	Neutral position drive joystick	"ON"= joystick out of neutral (pushed or pulled)
	SA12L	Left right steering	"ON"= if toogle switch pushed

	SM4B	Rocker on joystick for right steering function	"ON"= if rocker pushed
	SM4A	Rocker on joystick for left steering function	" ON"= if rocker pushed
	FU7	State of fuse FU7	"OFF"=fuse blown
	FU8	State of fuse FU8	"OFF"=fuse blown
	V12_Basket	Selection basket position	"ON"=if basket selected
	V12_Turret	Selection turret position	"ON"=turret selected
	SQ3L	Detection of boom angle position	"ON" if boom > 0°
	SQ10	Détecteur position télescope bras rentré	"ON"=if telescopic arm retracted
	SA4R	Basket rotation ( right)	"ON"=if toggle switch pushedr
	SA21 SA5 D	Basket compensation (down)	"ON"= if toggle switch pushed
	SQ3H	Detection of boom angle	"ON" if boom < 50°
	V12_Frame	Selection chassis	"ON"=if key on chassis position
	SB7	Engine preheating	"ON"=if toggle switch pushedr
	SA6 SA7 D	Jib descent	"ON"=if toggle switch pushed
	SA6 SA7 U	Jib lift	"ON"=if toggle switch pushed
	SA8I	Telescopic boom retraction	"ON"=if toggle switch pushed
	SA8O	Telescopic boom extension	"ON"=if toggle switch pushed
	SQ13	Détecteur rupture de chaîne (Tête)	"OFF"=rupture de chaîne
	SQ30toSQ33	Detection axle position ( front/rear)	"ON"= if axle extended (4 sensors in serial)
	SQ36&SQ37	Detection axle position ( front/rear)	"ON"= if axle extended (2 sensors in serial)
	SA19	Enable switch ( turret)	"ON"=if toggle switch pushed
	B2	Detection engine overheating	"OFF"=if engine overheating detected
	B3	Detection lack of engine oil pressure	"OFF"=if no engine oil pressure (engine in stop mode)
	SQ41	Detection of fuel level	"ON"=if on reserve (if more than 10secs , light is ON)
	SQ27	Detection of the position of the link part compensation	"ON"=if link part is in straight position when boom is fully stowed
	SQ38&SQ39	Detection of rear/front axle positions ( retracted)	"ON"= if front :rear axles retracted (2 sensors mounted in series)
DIGITAL OUTPUTS	YV1	LS (Load Sensing) Valve	"ON"=if LS valve LS piloted
	YV19A	Basket right rotation valve	"ON"=if valve energised
	YV24	Hydraulic generator valve	"ON"=if valve energised

YV22A	Rear right axle valve	"ON"=if valve energised
YV22B	Left right axle valve	"ON"=if valve energised
YV36	Safety valve for telescopic arm section II	"ON"=if valve energised
YV8_31A	Axle/stabilisers/steering valve	"ON"=if valve energised
YV8_31B	Axle/stabilisers/steering valve	"ON"=if valve energised
HL8	Fuel reserve light	"ON"=if on reserve
YV19B	Left basket rotation valve	"ON"=if valve energised
YV15A	Basket compensation ( down)	"ON"=if valve energised
YV15B	Basket compensation (lift)	"ON"=if valve energised
YV18A	Jib descent valve	"ON"=if valve energised
YV18B	Jib lifting valve	"ON"=if valve energised
KA51	Dispatching relay for telesopic arm or boom lift	"ON"=if arm telescopic / "OFF"= boom lift
YV9	Differential lock valve	"ON"=if valve energised
YV35	Safety valve for telescopic arm section I	"ON"=if valve energised
YV33	Oscillating axle unlock valve	"ON"=if valve energised
HL9	Fault machine indicator	"ON"=fault detected: - 1 blinking=CA01...CA21 - 2 blinking = default JY01...J04 - 3 blinking =default TR01...TR03 - 4 blinking = default CH01 - 5 blinking default AU01 - 6 blinking s= default AL01...AL03 - 8 blinking s= default LP01...LP03 - 9 blinking = default OL01
KM5	Preheating command relay	"ON"=if relay energised
KM6	Accelerator relay	" ON"=if relay energised
HA2	Buzzer platform	"ON"=buzzer beeping
KMG2	Relay for ECU module supply (power is maintained)	"ON"= when system remains under power for a few seconds)
HL14_15	Outreach limitation indicators ( both controls)	"ON"= when outreach limitation is reached ( blinking when at the limit of zone)

	HA4	Turret horn	"ON"=buzzer energised
	KP1	Relay for engine supply	" ON"=if relay energised
	KA2	Starter relay	" ON"=if relay energised
	HL4	Engine oil pressure indicator	"ON"= if lack of pressure detected
	HL3	Engine oil overheating indicator	"ON"=if overheating detected
	HL2_10	Overload indicator	"ON"= if system in overload
	HL12	Slope sensor indicator	"ON"=if in machine in slope/tilt
	KA37	Relay for accessories	" ON"=if relay energised
	KA50	Dispatching relay arm lift/ telescopic boom	"OFF"=arm lift / "ON"=telescopic boom
	GND_YV4	Command of the negative signal on PVG YV4	"ON"=GND YV4 connectéd (PVG supplied)
	GND_YV7	Command of the negative signal on PVG YV7	" ON"=GND YV7 connectéd (PVG supplied)
	YV34	Safety valve for turret rotation	"ON"=if valve energised
	YV40	Link part compensation valve	"ON"=if valve energised
	YV21A	Right steering front axle valve	"ON"=if valve energised
	YV12	Brake release valve	"ON"=if valve energised
	YV10	High speed valve	"ON"=if valve energised
	YV21B	Left steering front axle valve	"ON"=if valve energised
	YV38	Safety valve for arm lifting	"ON"=if valve energised
	YV27	Arm shifting valve	"ON"=if valve energised
	BPE_Learn	Communication on BPE overload board: calibration request	"ON"=if calibration is in process
ANALOG INPUTS	SL2	Boom angle transducer	input [0.0-5.0]V / sensor [4-20]mA through resistor R106 301Ohms-1/4W
	SL1	Boom angle transducer	input [0.0-5.0]V / sensor [4-20]mA through resistor R105 301Ohms-1/4W
	SL5	Arm angle transducer	input [0.0-5.0]V / sensor [4-20]mA through resistor R107 301Ohms-1/4W
	SL3	Boom length transducer	input [0-17]V / potentiométric sensor [0-Vbatt]V



	SL4	Boom length transducer	input [0-17]V / potentiométric sensor [0-Vbatt]V
	SL7	Arm length transducer	input [0-17]V / potentiométric sensor [0-Vbatt]V
	SL8	Arm length transducer	input [0-17]V / potentiométric sensor [0-Vbatt]V
	SM31Y	Joystick lift - Axe Y	input [4-20]mA
	SM2Y	Joystick telescopic - Axe Y	input [4-20]mA
	SM31X	Joystick orientation - Axe X	input [4-20]mA
	SM4Y	Joystick drive - Axe Y	input [4-20]mA
	VBAT	Power on ECU module node A	input [0-17]V
ANALOG OUTPUTS	YV30A	PWM (Pulse Width Modulation) FWD drive valve	0 to 1115mA
	YV30B	PWM (Pulse Width Modulation) REV drive valve	0 to 1115mA
	YV2	Proportional PVG valve for steering/extension stabilisers/jib-bsket movements	25% - 50% - 75% of Vbat
	YV5	Proportional PVG valve for orientation tourelle	25% - 50% - 75% of Vbat
	YV6	Proportional PVG valve for telescopic arm	25% - 50% - 75% of Vbat
	YV7	Proportional PVG valve for telescopic boom	25% - 50% - 75% of Vbat
	YV3	Proportional PVG valve for arm lift	25% - 50% - 75% of Vbatt
	YV4	Proportional PVG valve for boom lift	25% - 50% - 75% of Vbat
<b>Menu 4. DIAGNOSTIC</b>			
Reach limit	Mode	Datas to check the status of the machine	Not calib =machine must be calibrated. OK = machine is OK. Failure(s) = machine in restrictive mode.
	Abacus	Theoretical working envelop (mm)	in mm
Arm	SL5 angle	Value of arm angle SL5	in deg x100
	SQ7	State of the limit switch (arm upper position)	ON if arm full up (78°)
	SQ27	Sate of the ILS sensor of link compensation part	ON if link part is aligned straight position when machine is in stowed position
	SL7 length	Value of arm telescopic length	in mm
	SL8 length	Value of arm telescopic length	in mm
	Arm zone	zone of telescopic arm	compris entre 0 et 21
	SQ10	State of telescopic arm detection made by this limit switch	ON if telescopic arm fully retracted
	SQ44	State of ILS magnet sensor on the 1 <sup>st</sup> telescopic arm section	ON if front of magnet
SQ45	State of ILS magnet sensor on the 2 <sup>nd</sup> telescopic arm section	ON if front of magnet	
Boom	SL1 angle	Value of boom angle	in deg x 100
	SL2 angle	Value of boom angle	in deg x100
	SQ11	State of arm/boom limit switch	ON if arm and boom in stowed position
	SQ3H	State of boom switch < 50°	ON if boom < 50°
	SQ3L	State of boom switch > 0°	ON if boom > 0°

	SL3 length	Value of boom length	in mm
	SL4 length	Value of boom length	en mm
	SQ9	State of telescopic boom switch	ON if telescopic boom retracted
	SQ43	état du détecteur magnet télescope flèche	ON if in front of magnet
	Boom Zone	Telescopic boom zone	Zone between 0 et 11
	Error	Error in abacus/working envelop	in mm (<0 if inside abascus, =0 abascus OK que, >0 if outside abascus)
Overload	Jib angle	Relative value of jib angle	in deg x 10
	Abs. Angle	Absolute value of jib angle	in deg x 10
	Rod .pressure	Value of pression in small chamber of jib cylinder	in bar x 10
	Bore pressure	Value of pression in large chamber of jib cylinder	in bar x 10
Other	Axle out	State of sensors "axles extended"	OK if sensors are in the right position
	Axle in	State of sensors "axles retracted"	
<b>Menu 5. INFORMATIONS</b>			
DATE AND HOUR		Date and hour	* for modification in daily code level 3 only)
VERSIONS		Versions of softwares	
JOURNAL 1		Not available on this model	
<b>Menu 6. FAILURES</b>			
Alarms translation(drive)	TR01: Drive	Machine unfolded since more 3s and running in YV30A or YV30B higher than 650mA during more 200ms	Regulated CourantMaxMicro at 650mA
	TR02: Drive	Machine unfolded since more 3s and open B8 and FU8 present during more 500ms	check B8
	TR03: Drive	No drive since 100ms and open circuit on YV30A or YV30B since 100ms and FU70 present	Disconnected YV30A or disconnected YV30B or (YV30A or YV30B) supplied without validation of drive)
Alarms chains	CH01: Chain broken	Telscopic boom chian broken SQ12 or SQ13 at 0	Check chain+ limit switchs SQ12/SQ13
Alarms joysticks	JY01: Joystick Trans	Electric fault on drive joystick signal out of range ( < 0.2V or > 4.8V or signal between 0.65V and 2.35V and no neutral signal or signal between 2.65V and 4.35V and no neutral signal	Check joystick value on JY01 (0.5/2.5/4.5VDC)
	JY02: Joystick Teles	Electric fault on telescopic joystick signal out of range ( < 0.2V or > 4.8V or signal between 0.65V and 2.35V and no neutral signal or signal between 2.65V and 4.35V and no neutral signal	Check joystick value on JY02 (0.5/2.5/4.5VDC)
	JY03: Joystick Lift	Electric fault on orientation/lift joystick signal out of range ( < 0.2V or > 4.8V or signal between 0.65V and 2.35V and no neutral signal or signal between 2.65V and 4.35V and no neutral signal	Check joystick value on JY03 (0.5/2.5/4.5VDC)
Alarms sensors and transducers	CA01: SL1 out of range	SL1 out of range Angle SL1 > at + 75° or < at minus 45°	Check SL1
	CA02: SL2 out of range	SL2 out of range Angle SL2 > + 75° or < at minus 45°	Check SL2

CA03: out of range	SL3 out of range Length SL3 > (5980+150)mm or < at -150mm.	Check SL3
CA04: out of range	SL4 out of range Length SL4 > (5980+150)mm or < at -150mm.	Check SL4
CA05: out of range	SL5 out of range Angle SL5 > at + 83° or < minus 5°	Check SL5
CA06: out of range	SL7 out of range Length SL7 > (7655+150)mm or < at -150mm.	Check SL7
CA07: out of range	SL8 out of range Length SL8 > (7655+150)mm or < at -150mm.	Check SL8
CA08: SL1-SL2 diff	Incoherence between SL1 and SL2 above the tolerance Difference between SL1 and SL2 > 3°	Check SL1 et SL2
CA09: SL3-SL4 diff	Incoherence between SL3 et SL4 above the tolerance Difference between SL3 et SL4 > 250mm	Check SL3 et SL4
CA10: SL7-SL8 diff	Incoherence between SL7 et SL8 above the tolerance Difference between SL7 et SL8 > 250mm	Check SL7 et SL8
CA11: Boom Ang-SQ3H	Incoherence between angle flèche et SQ3H Angle flèche > 55° et SQ3H à 1	Check SQ3H
CA12: Boom Ang-SQ3L	Incoherence between boom angle and SQ3L Boom angle < -5° and SQ3L = 1	Check SQ3L
CA13: Boom Ang-SQ11	Incoherence between boom angle and SQ11 (boom angle > 10° or boom angle < -10° or boom angle > 10°) and SQ11 = 1	Check SQ11
CA14: Arm Ang-SQ7	Incoherence between arm angle and SQ7 Arm angle < 74° and SQ7 = 1	Check SQ7 and SL5
CA15: Arm Ang-SQ27	Incoherence between arm angle and SQ27 arm angle > 10° and SQ27 = 1	Check SQ27 and SL5
CA16: Arm Length-SQ10	Incoherence between arm length and SQ10 Arm length > 200mm and SQ10 = 1	Check SQ10 and SL7-SL8
CA17: Arm Length-Zone	Incoherence between arm length and SQ44-SQ45 (ILS zones ) Magnet 0 : 0mm (Zone 0) (Zone 1) Magnet 1 : 640mm (Zone 2) (Zone 3) Magnet 2 : 1280mm (Zone 4) (Zone 5) Magnet 3 : 1920mm (Zone 6) (Zone 7) Magnet 4 : 2560mm (Zone 8) (Zone 9) Magnet 5 : 3200mm (Zone 10) (Zone 11) Magnet 6 : 4480mm (Zone 12) (Zone 13) Magnet 7 : 5120mm (Zone 14) (Zone 15) Magnet 8 : 5760mm (Zone 16) (Zone 17) Magnet 9 : 6400mm (Zone 18) (Zone 19) Magnet 10 : 7040mm (Zone 20) (Zone 21) The alarm will appear if length and zone are incoherent at ~ 140mm	Check SQ44-SQ45 (+ magnets) and SL7-SL8
CA18: Boom Length-SQ9	Incoherence between boom length and SQ9 boom length > 200mm and SQ9 = 1	Check SQ9 and SL3-SL4

	CA19: Boom Length-Zone	Incoherence between boom length and SQ43 (ILS zones) Magnet 0 : 0mm (Zone 0) (Zone 1) Magnet 1 : 3796mm (Zone 2) (Zone 3) Magnet 2 : 4246mm (Zone 4) (Zone 5) Magnet 3 : 4696mm (Zone 6) (Zone 7) Magnet 4 : 5146mm (Zone 8) (Zone 9) Magnet 5 : 5596mm (Zone 10) (Zone 11) The alarm will appear if length and zone are incoherent at ~ 140mm.	Check SQ43 (+ magnets) and SL3-SL4
	CA20: Arm Zone-SQ10	Incoherence between SQ44-SQ45 (arm zones) and SQ10 Arm zones $\geq 2$ and SQ10 = 1	Check SQ44-SQ45 (+magnets) and SQ10
	CA21: Boom Zone-SQ9	Incoherence between SQ43 (boom zones) and SQ9 boom zones $\geq 2$ and SQ9 = 1	Check SQ43 (+magnets) et SQ9
Alarms reach limitation arm/boom	LP01: Fr.LimitOut Arm	Arm front reach limitation Angle bras $< 74^\circ$ and arm length $> 500$ mm.	Check outreach limitation system : all transducers (SL1,SL2, SL3, SL4, SL5), actuators YV3/YV4/YV6 and YV7
	LP02: Fr.LimitOut Boo	Boom front reach limitation Arm angle $< 70^\circ$ and Boom angle $> 58^\circ$	
	LP03: Fr.LimitOut Boo	Boom rear reach limitation Error on abascus/envelop $> 350$ mm	
Alarms overload system	OL01	Load Management System absent	Proceed to overload calibration
Alarms fuses	AL01: FU70 20A fired	FU70 burnt FU70 at 0	Check fuse FU70
	AL02: FU8 5A fired	FU8 burnt FU8 at 0	Check fuse FU8
	AL03: Key selector	Problem on key selection SA1 (FU5 and FU6 and FU2 = 1) or (FU5 and FU6 and FU2 = 0)	Check key selector SA1
Alarms emergency circuit	AU01: Emergency stop	Fault on emergency circuit KMG1 wire 254 at 0 and FU70 = 1	Check emergency circuits and relay KMG1
Alarms module Head battery	BT01: Battery low	Year provided by ECU node A is at 2000 when power is ON	Replace Head module
Alarms EEPROM on Head module	EP01	Fault on EEPROM inside the ECUU module node A	Replace Head module



## 9.4. CALIBRATION PROCESS

### 9.4.1. LOAD SYSTEM

During the procedure:

- The SA1 key must remain switched ON.
- The engine is running.
- The machine is on a flat floor.
- The machine is in stowed position.
- The calibration must be done from the turret control box.

Caution, it is necessary to use the OPTIMIZER with the code level 2 ( code 2031).

With an electronic level, put the basket at 0° by using the basket compensation switch.

Go in the menu **2.Parameters > 2.6. Calibration – Overload learning?**

Put 250 kg in the basket and validate



- Lower the jib to the maximum and maintain the command activated during 5 seconds.
- Raise the jib to the maximum. (The jib will stop automatically every 5°.)
- Once the jib in maximum upper position, maintain the command activated during 5 seconds.
- Lower the jib to the lowest position.
- Raise the jib again to approximately 10°.
- Switch off and switch on the machine.
- The procedure is finished.

Remark: If a step has not been respected, switch off the machine and start again the full process from the beginning.

### 9.4.2. OUTREACH SYSTEM

During the procedure:

- The SA1 key must remain switched ON.
- The engine is running.
- The machine is on a flat floor.
- The calibration must be done from the turret control box.
- During all movements, the dead man switch must be activated.

Caution, it is necessary to use the optimizer with the code level 3 (daily code).

The respect of the positioning of all elements of the machine is very important.

If these rules are not respected, the sensors would make some wrong measurements and create some risks for the stability of the machine.

The module is in calibration mode: The engine and reach limit lights are flashing, the buzzer is beeping.

If the machine is not in calibration mode, it is necessary to cancel the previous calibration as explained below:

## Cancelling of the previous calibration:

- Menu 2.PARAMETERS / 2.6.1 CALIBRATION / PX / Cancel ?

```
Px:Cancel Reach Lim?
Disable
```

- Validate :



- Switch OFF and switch ON the machine, the previous calibration is cancelled.

## Position 1: Machine stowed:

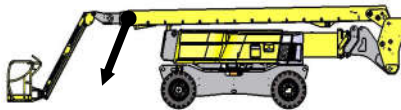

- Boom and arm must be on the turret, Boom and arm telescopes must be fully retracted, the turret must be in the axis and the jib must be in lower position.

```
P1:Machine stowed ?
Disable
```

- Validate the position 1 in the menu Parameters/Calibration/P1: Machine stowed?



- If OK appears, go to step 2. If not, check the faulty sensor and start again the full process from the beginning.

- At this step, it is possible to check the sensors value (Menu INPUT/OUTPUT or DIAGNOSTIC/BOOM):

SL3: 5.71 % of Vbat +/- 3.8 %  
 SL4: 94.25 % of Vbat +/- 3.8 %  
 SL5 = 1.40V +/- 0.10V  
 SL7 = 6.40% of Vbat +/- 3.8%  
 SL8 = 94.25% of Vbat +/- 3.8%

SQ10 = ON  
 SQ9 = ON  
 SQ11 = ON  
 SQ40 = ON  
 SQ42 = ON

SQ1 = ON  
 SQ3H = ON  
 SQ3L = ON  
 SQ7 = OFF

## Position 2: Boom at +70°:

- Raise the boom to the maximum.

```
P2:Boom to 70 deg ?
Disable
```

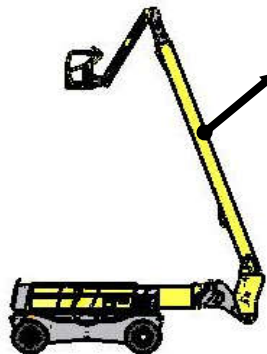

- Validate the position 2 in the menu Parameters/Calibration/P2: Boom to 70 deg?



- If OK appears, go to step 3. If not, check the faulty sensor and start again the full process from the beginning.

- At this step, it is possible to check the sensors value (Menu INPUT/OUTPUT or DIAGNOSTIC/BOOM):

SL1 = 0,98V +/- 0,10V [198 +/- 21]  
SL2 = 4,53V +/- 0,10V [971 +/- 21]

SQ10 = ON  
SQ9 = ON  
SQ11 = OFF  
SQ40 = ON  
SQ42 = ON

SQ1 = ON  
SQ3H = OFF  
SQ3L = ON  
SQ7 = OFF

**Position 3: Telescopic boom fully extended:**

- Extend fully the telescopic boom extension.



- Validate the position 3 in the menu Parameters/Calibration/P3: Teles Boom out?



- If OK appears, go to step 4. If not, check the faulty sensor and start again the full process from the beginning.

- At this step, it is possible to check the sensors value (Menu INPUT/OUTPUT or DIAGNOSTIC/BOOM):

SL3 = 56.29% of Vbat +/- 3.8%  
SL4 = 43.15% of Vbat +/- 3.8%

SQ10 = ON  
SQ9 = OFF  
SQ11 = OFF  
SQ40 = ON  
SQ42 = ON

SQ1 = ON  
SQ3H = OFF  
SQ3L = ON  
SQ7 = OFF

## Position 4: Telescopic boom fully retracted:

- Fully retract the telescopic boom.

```
P4:Teles Boom in  ?
Disable
```



- Validate the position 4 in the menu Parameters/Calibration/P4: Teles Boom in?



- If OK appears, go to step 5. If not, check the faulty sensor and start again the full process from the beginning.

- At this step, it is possible to check the sensors value (Menu INPUT/OUTPUT or DIAGNOSTIC/BOOM):

SQ10 = ON	SQ1 = ON
SQ9 = ON	SQ3H = OFF
SQ11 = OFF	SQ3L = ON
SQ40 = ON	SQ7 = OFF
SQ42 = ON	

## Position 5: Boom at 0°:

- Lower the boom to 0°.

```
P5:Boom to 0 deg  ?
Disable
```



- Validate the position 5 in the menu Parameters/Calibration/P5: Boom to 0 deg?



- If OK appears, go to step 6. If not, check the faulty sensor and start again the full process from the beginning.

- At this step, it is possible to check the sensors value (Menu INPUT/OUTPUT or DIAGNOSTIC/BOOM):

SQ10 = ON	SQ40 = ON	SQ3H = ON
SQ9 = ON	SQ42 = ON	SQ3L = ON
SQ11 = ON	SQ1 = ON	SQ7 = OFF



## Position 6: Arm at 78°:

- Raise the arm to the maximum.

```
P6:Arm to 78 deg ?
Disable
```

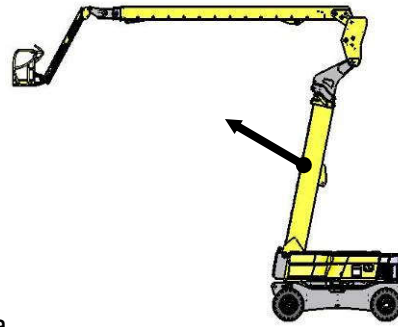

- Validate the position 6 in the menu Parameters/Calibration/Arm to 78 deg.



- If OK appears, go to step 7. If not, check the faulty sensor and start again the full process from the beginning.

- At this step, it is possible to check the sensors value (Menu INPUT/OUTPUT or DIAGNOSTIC/BOOM):

SL5 = 4,09V +/- 0.10V

SQ10 = ON  
 SQ9 = ON  
 SQ11 = OFF  
 SQ40 = ON  
 SQ42 = ON

SQ1 = ON  
 SQ3H = ON  
 SQ3L = ON  
 SQ7 = ON

## Position 7: Telescopic arm fully extended:

- Fully extend the telescopic arm extensions

```
P7:Teles Arm out ?
Disable
```

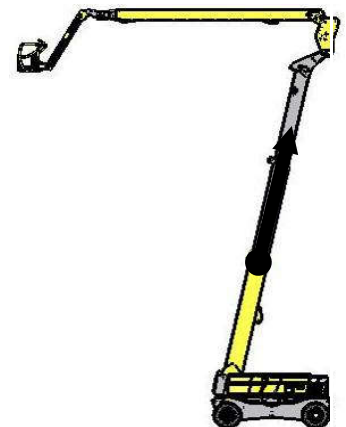

- Validate the position 7 in the menu Parameters/Calibration/P7: Teles Arm out?



- If OK appears, go to step 8. If not, check the faulty sensor and start again the full process from the beginning.

- At this step, it is possible to check the sensors value (Menu INPUT/OUTPUT or DIAGNOSTIC/BOOM):

SL7 = 72,29% of Vbat +/- 3,8%  
 SL8 = 28,53% of Vbat +/- 3,8%

SQ10 = OFF  
 SQ9 = ON  
 SQ11 = OFF

SQ40 = ON  
 SQ42 = ON  
 SQ1 = ON

SQ3H = ON  
 SQ3L = ON  
 SQ7 = ON

**Position 8: Boom at -40°:**

- Lower the boom to the maximum.

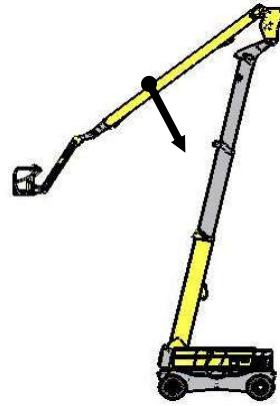

P8:Boom to -40 deg ?  
Disable

- Validate the position 8 in the menu Parameters/Calibration/P8: Boom to -40 deg?



- If OK appears, go to step 9. If not, check the faulty sensor and start again the full process from the beginning.

- At this step, it is possible to check the sensors value (Menu INPUT/OUTPUT or DIAGNOSTIC/BOOM):

SL1 = 4,82V +/-0,10V [977 +/- 21]  
SL2 = 0,95V +/- 0,10V [193 +/- 21]

SQ10 = OFF  
SQ9 = ON  
SQ11 = OFF  
SQ40 = ON  
SQ42 = ON

SQ1 = ON  
SQ3H = ON  
SQ3L = OFF  
SQ7 = ON

**Position 9: Boom at +5°:**

- Lift the boom to the electrical cut at +5°

P9:Boom to 5 deg ?  
Disable

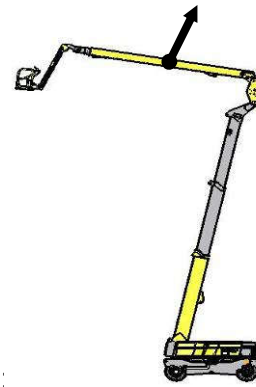

- Validate the position 9 in the menu Parameters/Calibration/P9:



- If OK appears, go to step 10. If not, check the faulty sensor and start again the full process from the beginning.

At this step, it is possible to check the sensors value (Menu INPUT/OUTPUT or DIAGNOSTIC/BOOM):

SQ10 = OFF  
SQ7=ON  
SQ9 = ON

SQ11 = OFF  
SQ40 = ON

SQ42 = ON  
SQ1 = ON

SQ3H = ON  
SQ3L – ON

**Position 10: Arm at 0°:**

- Retract and lower completely the arm.

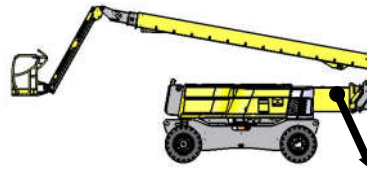
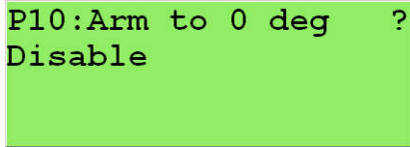

- Validate the position 10 in the menu Parameters/Calibration/P10: Arm to 0 deg?



- If OK appears, go to step 11. If not, check the faulty sensor and start again the full process from the beginning.

At this step, it is possible to check the sensors value (Menu INPUT/OUTPUT or DIAGNOSTIC/BOOM):

SQ10 = ON	SQ1 = ON
SQ9 = ON	SQ3H = ON
SQ11 = OFF	SQ3L = ON
SQ40 = ON	SQ7 = OFF
SQ42 = ON	

**Position 11: Boom at 0°:**

- Lower completely the boom.

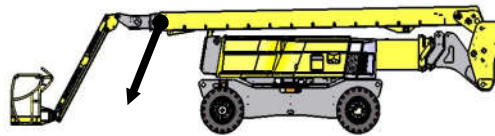
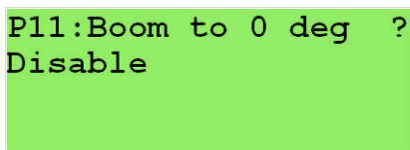

- Validate the position 11 in the menu Parameters/Calibration/P11: Boom to 0deg?



- If OK appears, the calibration is done, the turret lights stop flashing, the buzzer stops beeping. If not, check the faulty sensor and start again the full process from the beginning.

At this step, it is possible to check the sensors value (Menu INPUT/OUTPUT or DIAGNOSTIC/BOOM):

SQ10 = ON	SQ1 = ON
SQ9 = ON	SQ3H = ON
SQ11 = ON	SQ3L = ON
SQ40 = ON	SQ7 = OFF
SQ42 = ON	

### How to check the accuracy of the sensors adjustment:

- 1) Reset all failures "Times" in menu 6.FAILURES
- 2) Validate in 2.4. MAINTENANCE/ Option "Factory tolerances".  
Once activated, this option will reduce the tolerances on the failures' detection.  
(It will automatically deactivate when machine is switched OFF).
- 3) Proceed to a complete cycle:  
Machine in stowed position.  
Raise the arm to 78°, and extend both telescopes.  
Raise the boom to 70° and extend fully the telescopes.  
Lower the main boom at - 40° (The telescopic boom should retract by itself when reaching the limit of the working zone)
- 4) Put back the machine in stowed position.
- 5) If some failures appear during this cycle, check the mounting of the concerned sensors (gap, connection...) and solve the problem.



## 10. LIST OF SCHEMATICS

---

Below is all schematics (electric/hydraulic) of the different versions of the studied model

10.1. **HYDRAULIC FUNCTION 159P325420**

**HYDROSTATIC TRANSMISSION**

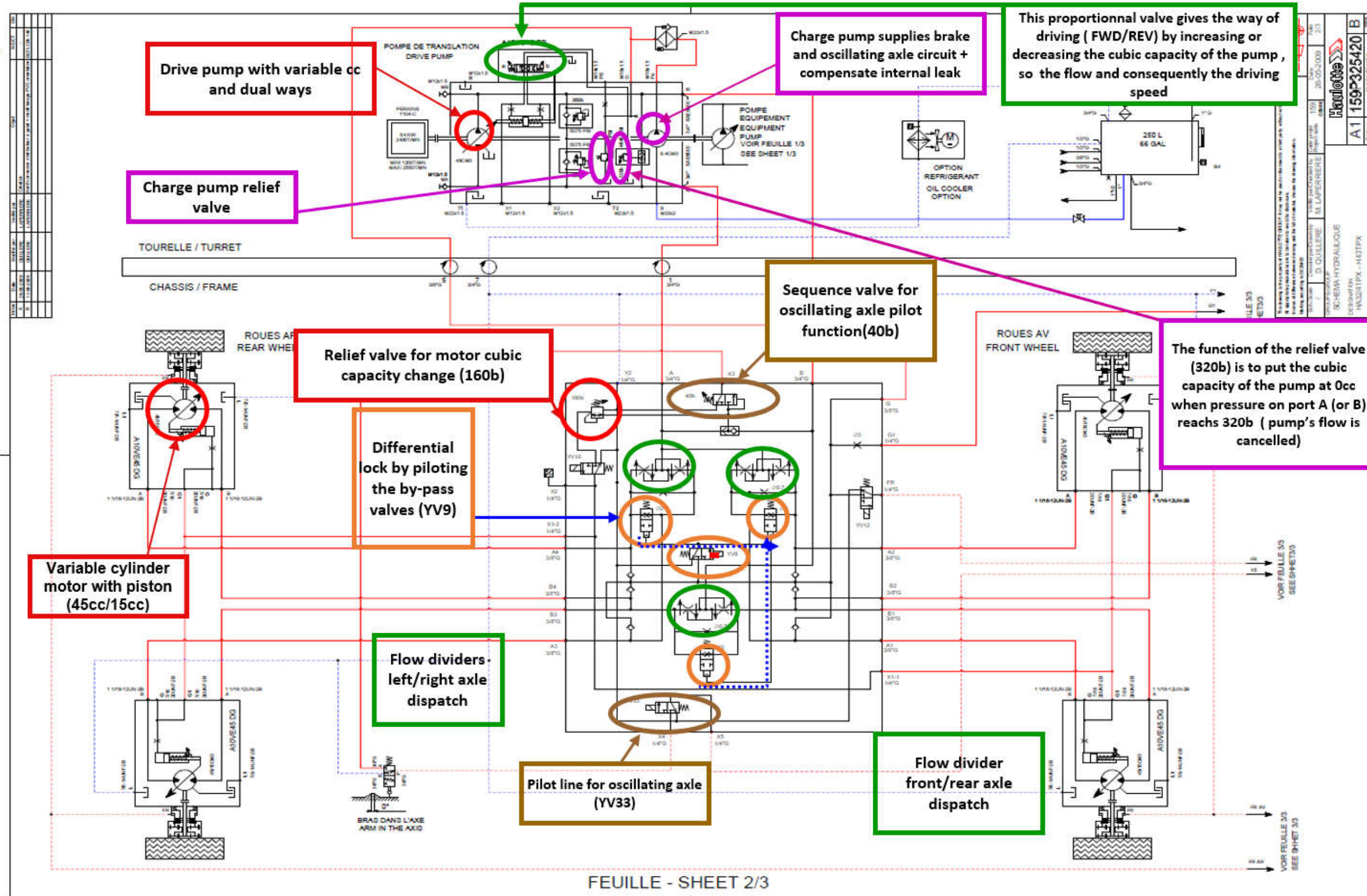

REV.	DESCRIPTION	DATE
1	PRELIMINAIRE	20-05-2009
2	REVISION	20-05-2009
3	REVISION	20-05-2009
4	REVISION	20-05-2009
5	REVISION	20-05-2009
6	REVISION	20-05-2009
7	REVISION	20-05-2009
8	REVISION	20-05-2009
9	REVISION	20-05-2009
10	REVISION	20-05-2009
11	REVISION	20-05-2009
12	REVISION	20-05-2009
13	REVISION	20-05-2009
14	REVISION	20-05-2009
15	REVISION	20-05-2009
16	REVISION	20-05-2009
17	REVISION	20-05-2009
18	REVISION	20-05-2009
19	REVISION	20-05-2009
20	REVISION	20-05-2009
21	REVISION	20-05-2009
22	REVISION	20-05-2009
23	REVISION	20-05-2009
24	REVISION	20-05-2009
25	REVISION	20-05-2009
26	REVISION	20-05-2009
27	REVISION	20-05-2009
28	REVISION	20-05-2009
29	REVISION	20-05-2009
30	REVISION	20-05-2009
31	REVISION	20-05-2009
32	REVISION	20-05-2009
33	REVISION	20-05-2009
34	REVISION	20-05-2009
35	REVISION	20-05-2009
36	REVISION	20-05-2009
37	REVISION	20-05-2009
38	REVISION	20-05-2009
39	REVISION	20-05-2009
40	REVISION	20-05-2009
41	REVISION	20-05-2009
42	REVISION	20-05-2009
43	REVISION	20-05-2009
44	REVISION	20-05-2009
45	REVISION	20-05-2009
46	REVISION	20-05-2009
47	REVISION	20-05-2009
48	REVISION	20-05-2009
49	REVISION	20-05-2009
50	REVISION	20-05-2009
51	REVISION	20-05-2009
52	REVISION	20-05-2009
53	REVISION	20-05-2009
54	REVISION	20-05-2009
55	REVISION	20-05-2009
56	REVISION	20-05-2009
57	REVISION	20-05-2009
58	REVISION	20-05-2009
59	REVISION	20-05-2009
60	REVISION	20-05-2009
61	REVISION	20-05-2009
62	REVISION	20-05-2009
63	REVISION	20-05-2009
64	REVISION	20-05-2009
65	REVISION	20-05-2009
66	REVISION	20-05-2009
67	REVISION	20-05-2009
68	REVISION	20-05-2009
69	REVISION	20-05-2009
70	REVISION	20-05-2009
71	REVISION	20-05-2009
72	REVISION	20-05-2009
73	REVISION	20-05-2009
74	REVISION	20-05-2009
75	REVISION	20-05-2009
76	REVISION	20-05-2009
77	REVISION	20-05-2009
78	REVISION	20-05-2009
79	REVISION	20-05-2009
80	REVISION	20-05-2009
81	REVISION	20-05-2009
82	REVISION	20-05-2009
83	REVISION	20-05-2009
84	REVISION	20-05-2009
85	REVISION	20-05-2009
86	REVISION	20-05-2009
87	REVISION	20-05-2009
88	REVISION	20-05-2009
89	REVISION	20-05-2009
90	REVISION	20-05-2009
91	REVISION	20-05-2009
92	REVISION	20-05-2009
93	REVISION	20-05-2009
94	REVISION	20-05-2009
95	REVISION	20-05-2009
96	REVISION	20-05-2009
97	REVISION	20-05-2009
98	REVISION	20-05-2009
99	REVISION	20-05-2009
100	REVISION	20-05-2009



# LOW SPEED DRIVE (FWD)

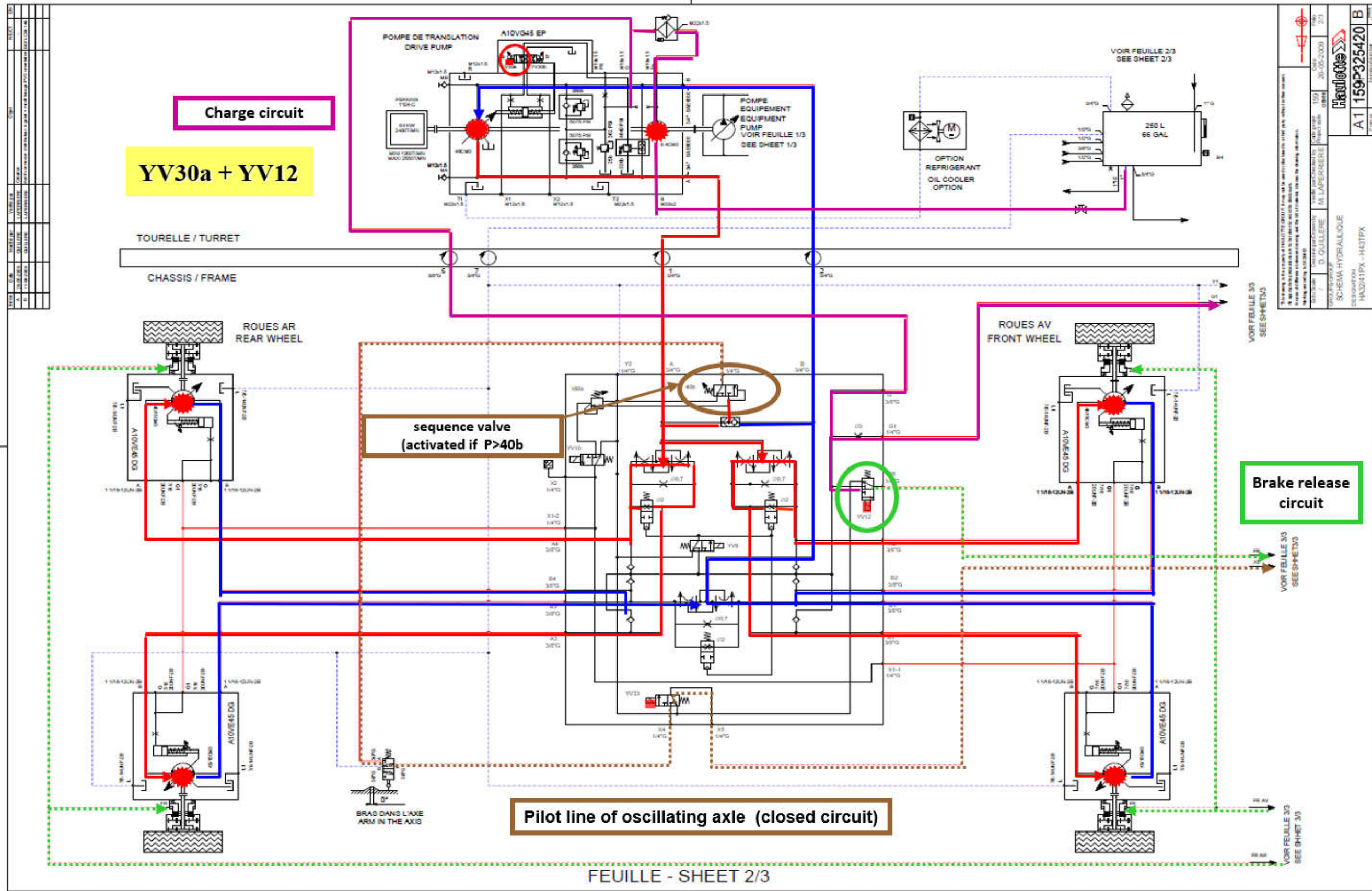

REV.	DATE	DESCRIPTION

Haulotte  
 D. GUILLERE M. LAPERRERE  
 20-05-2009  
 SCHEMA HYDRAULIQUE  
 HA041PX-H43TPX  
**A1 159P325420 B**  
 2/3

FEUILLE - SHEET 2/3



# HIGH SPEED DRIVE (FWD)

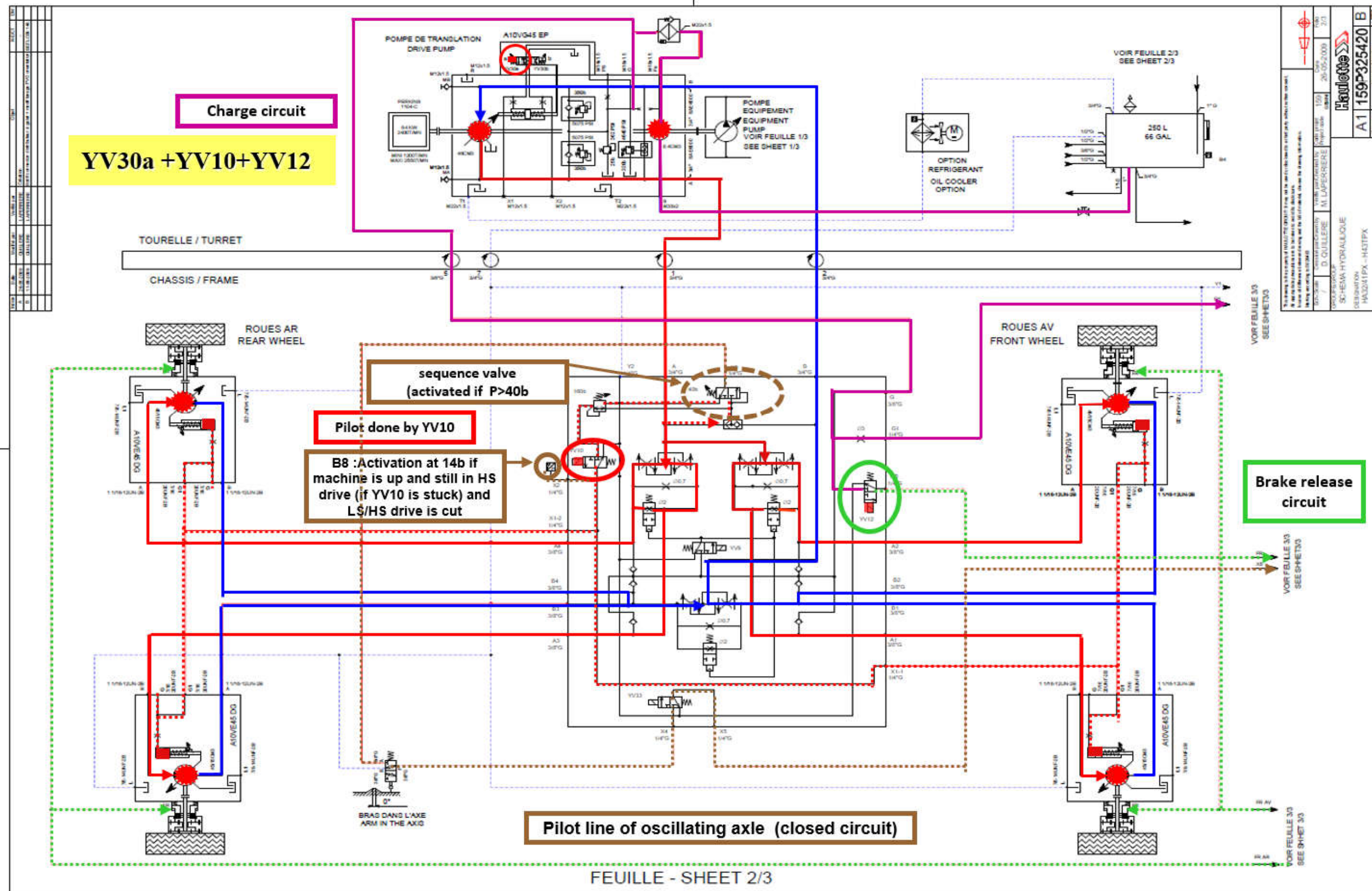

D. QUILIERE M. LAPERRERE		
DATE	20-05-2008	006
REVISION		2/3
A1 159P325420 B		
SCHEMA HYDRAULIQUE HAZ011PX - H41TPX		



## OSCILLATING AXLE

**CONDITION FOR FREE AXLE :**

- Turret aligned
- Drive mode
- YV33 = 1

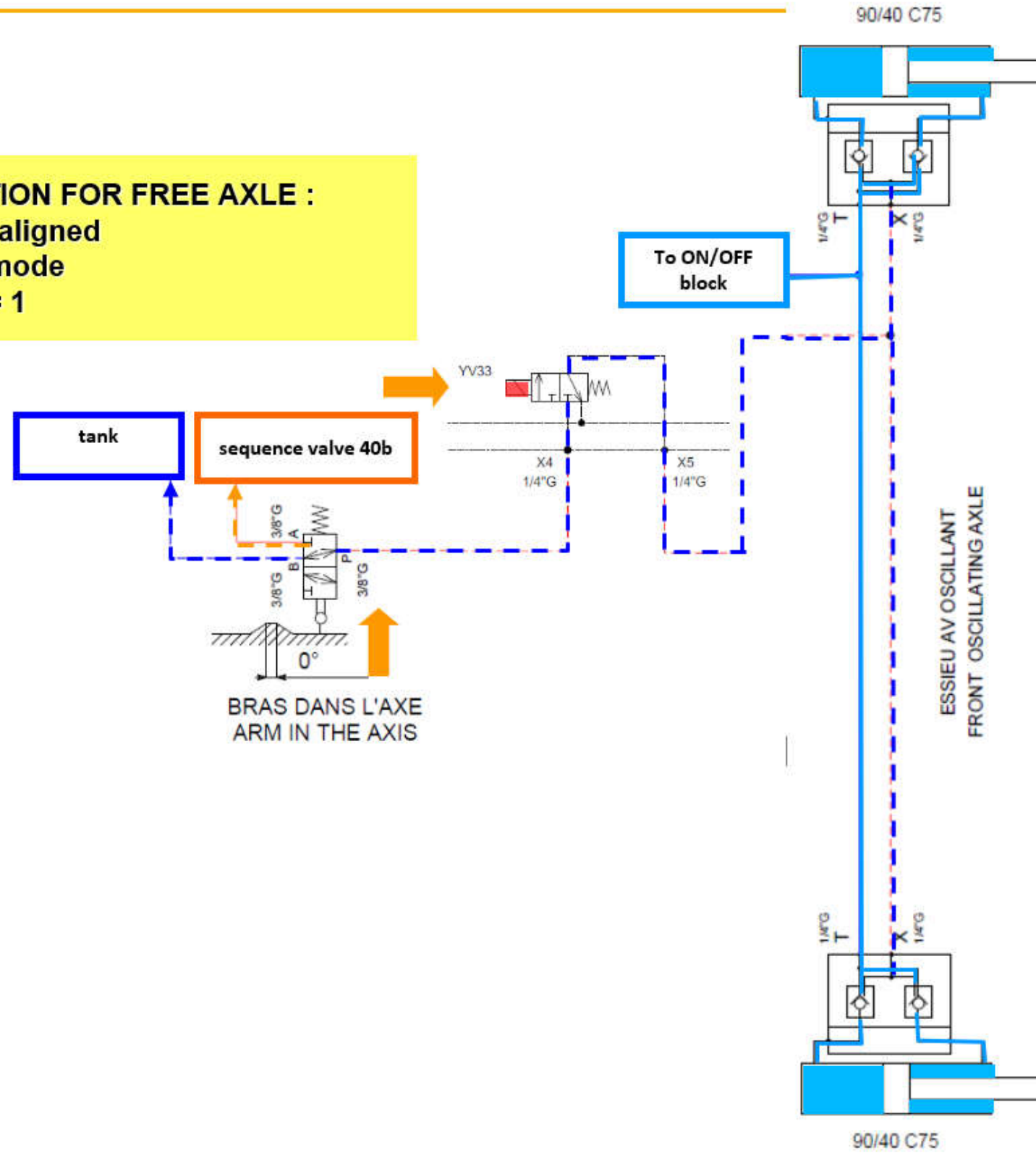

## OUTRIGGERS + AXLE EXTENSION (rear axle)

The lever must be held during the whole process in order to prevent mechanical strength on the axle during the movements ( retraction and/or extension)

When YV 8 =1 , all axes movements are authorised

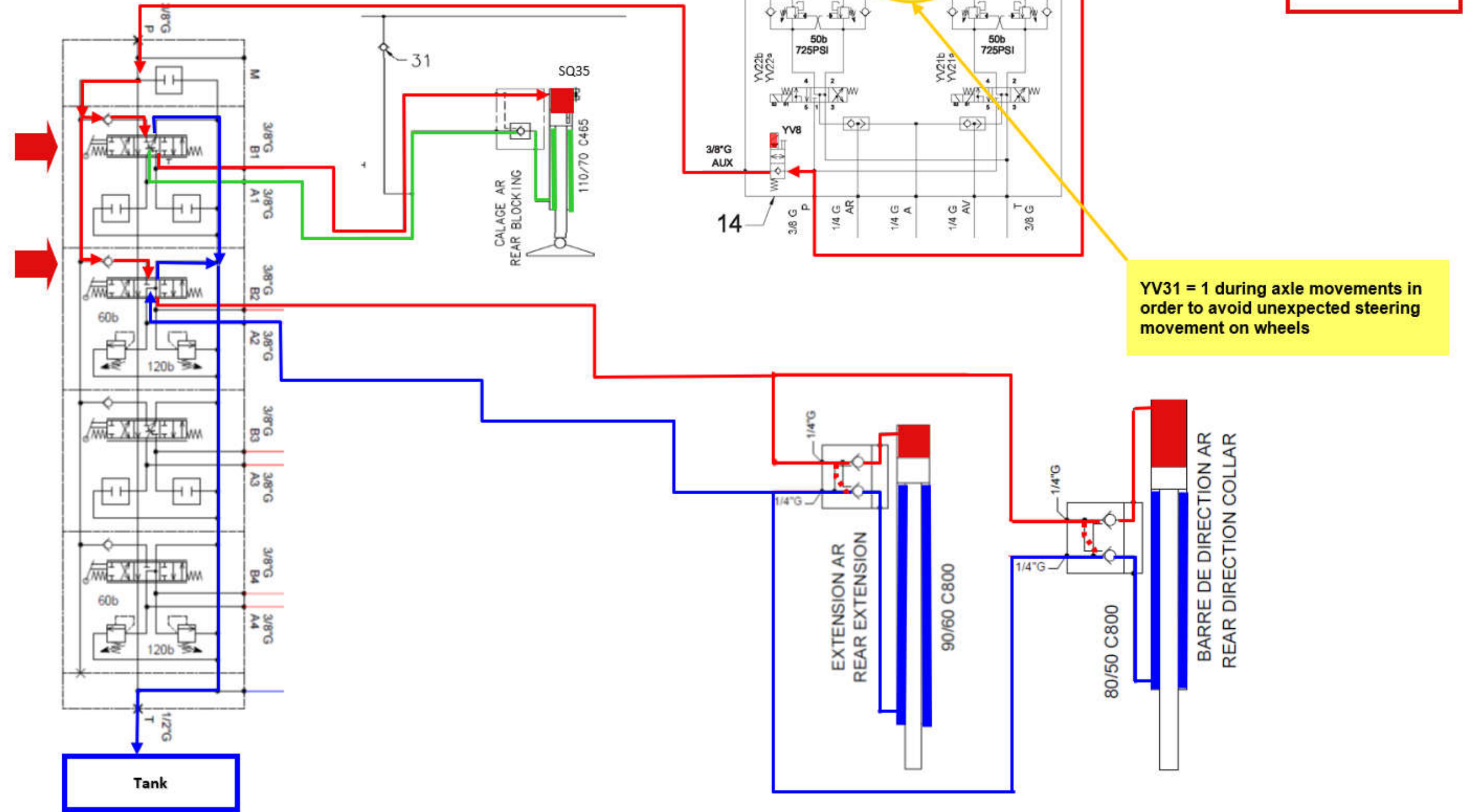

YV31 = 1 during axle movements in order to avoid unexpected steering movement on wheels

PVG YV2 A6

## STEERING FRONT - REAR

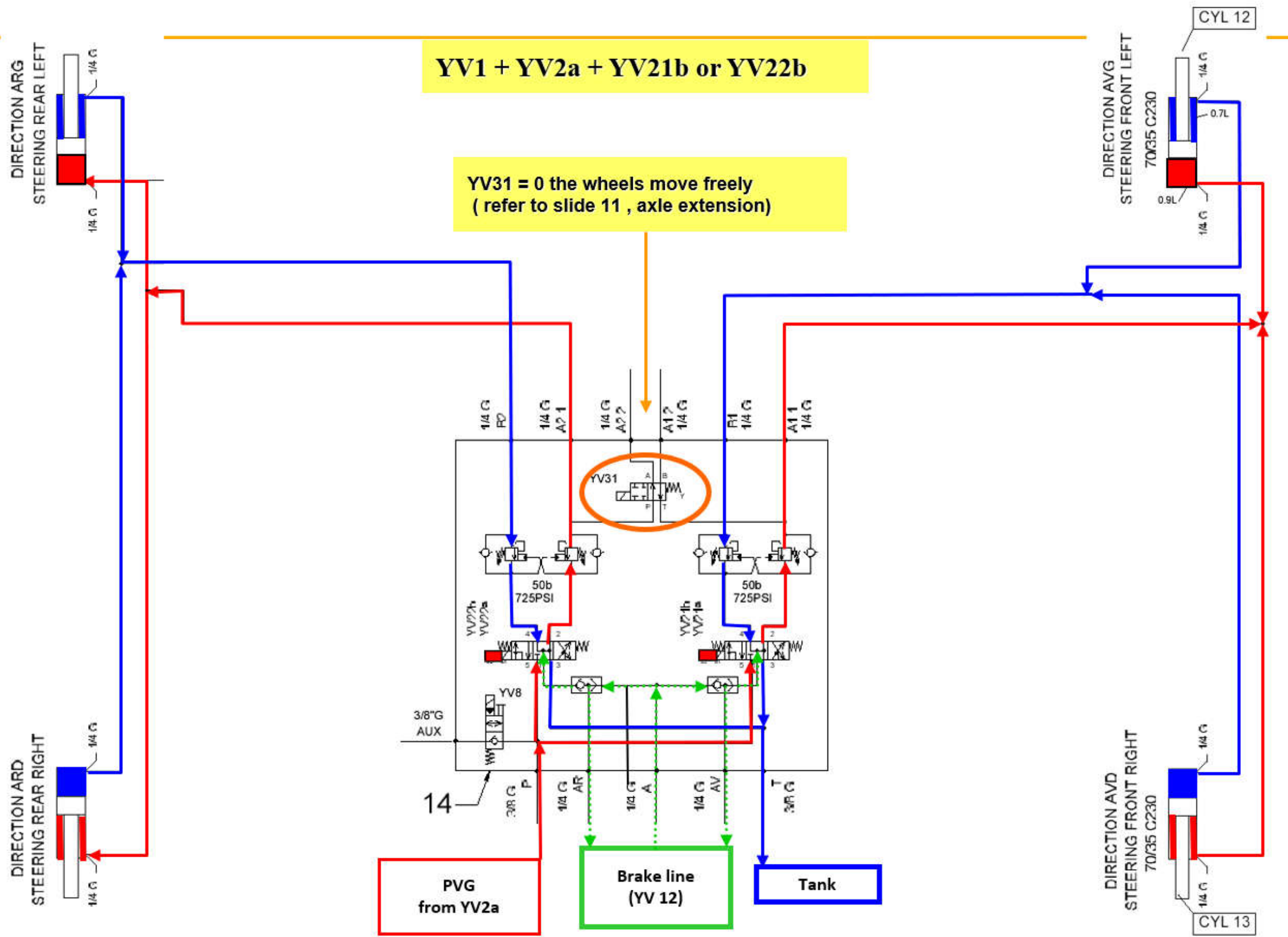



# ARM LIFT

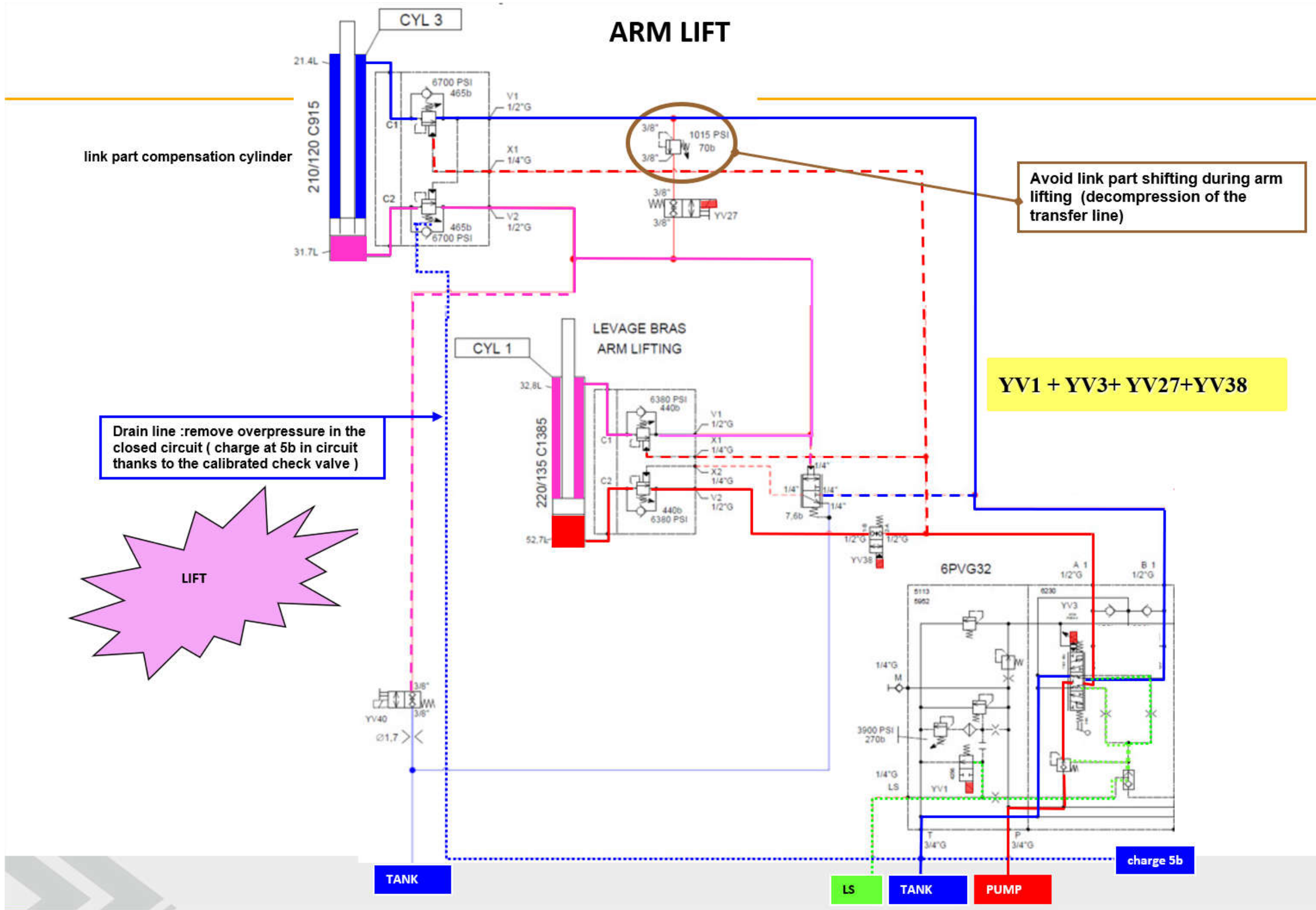



# ARM DESCENT CASE 1

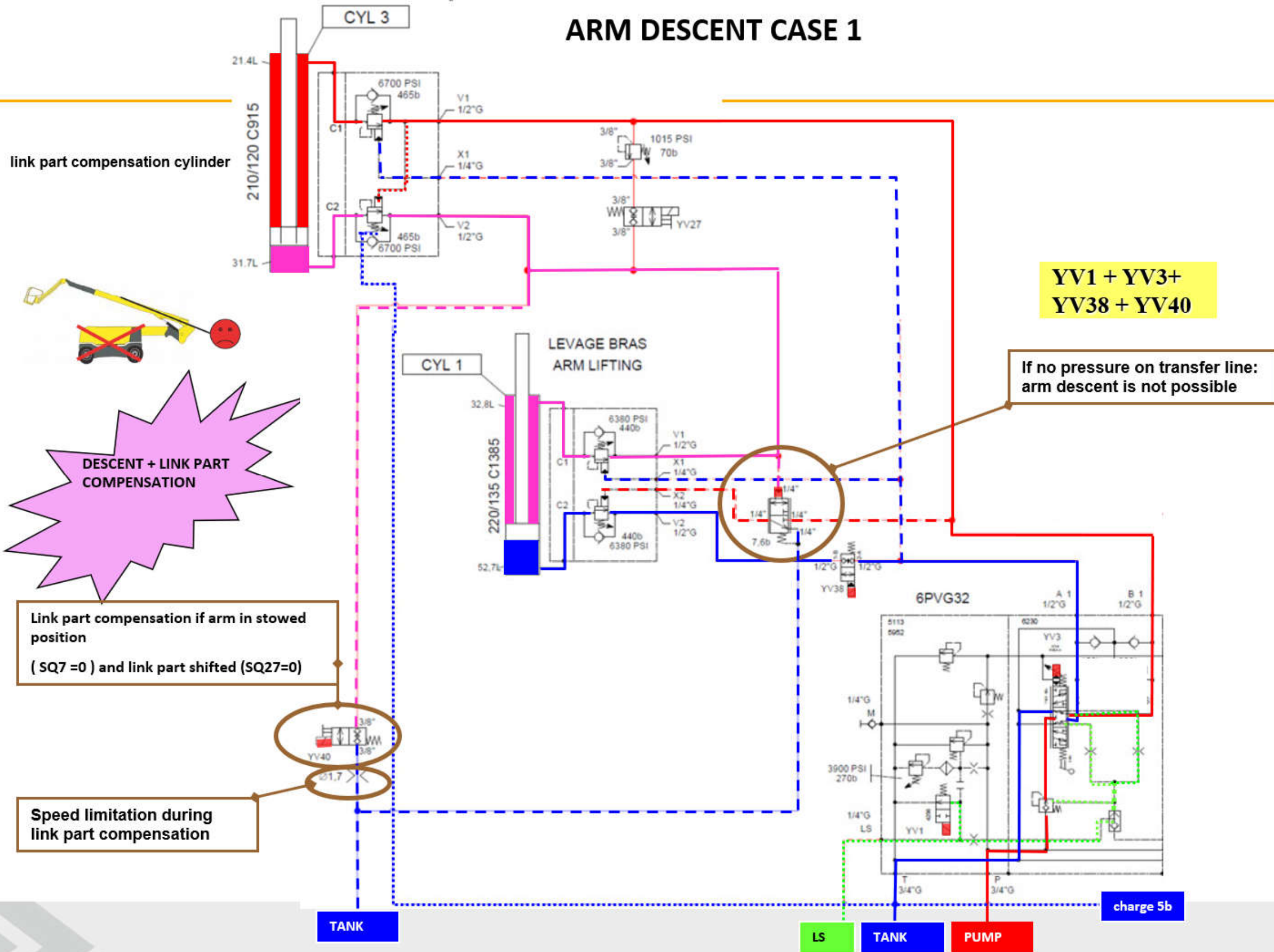

## ARM DESCENT CASE 2

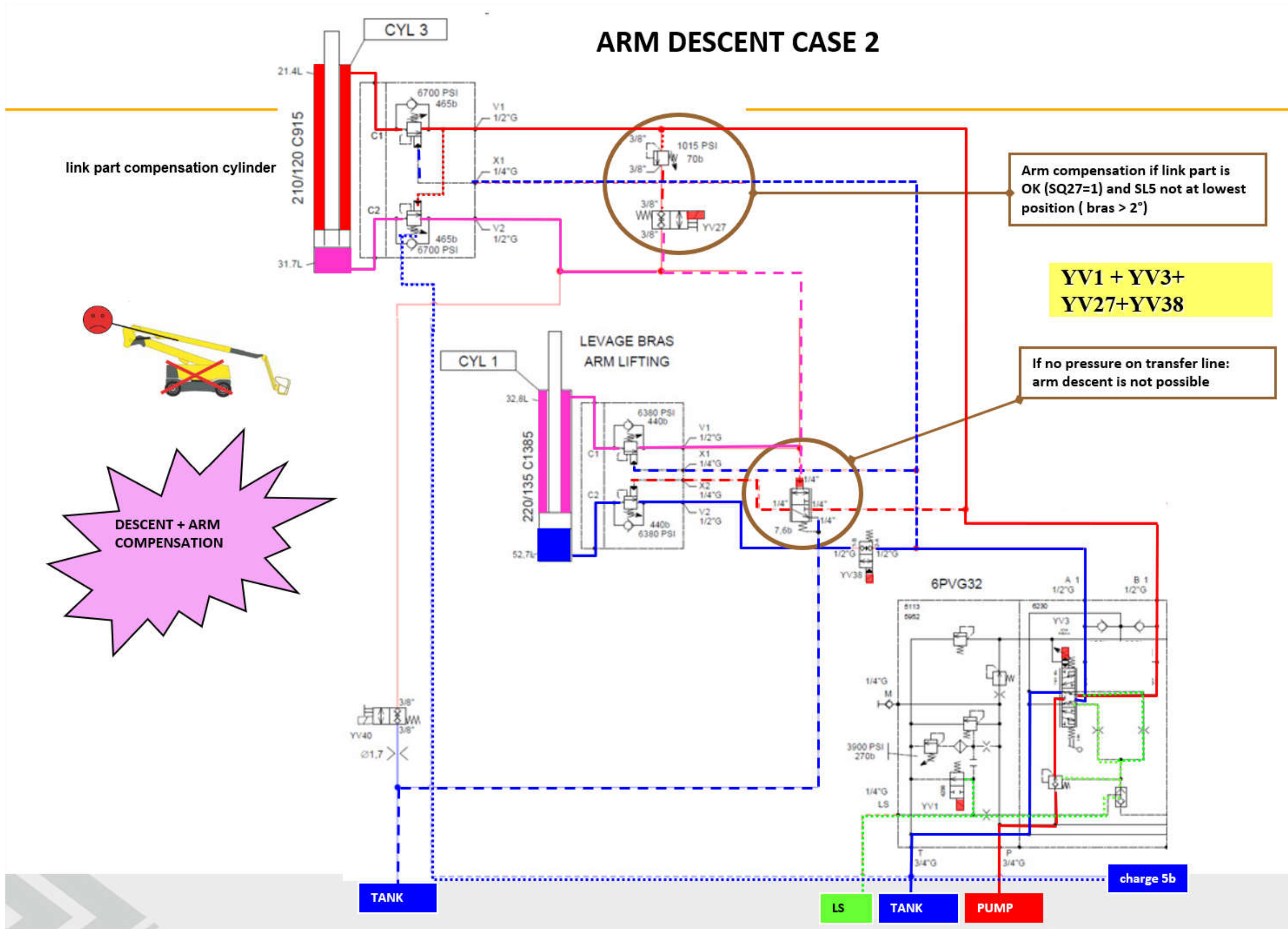



# ARM LIFT then TELESCOPIC EXTENSION

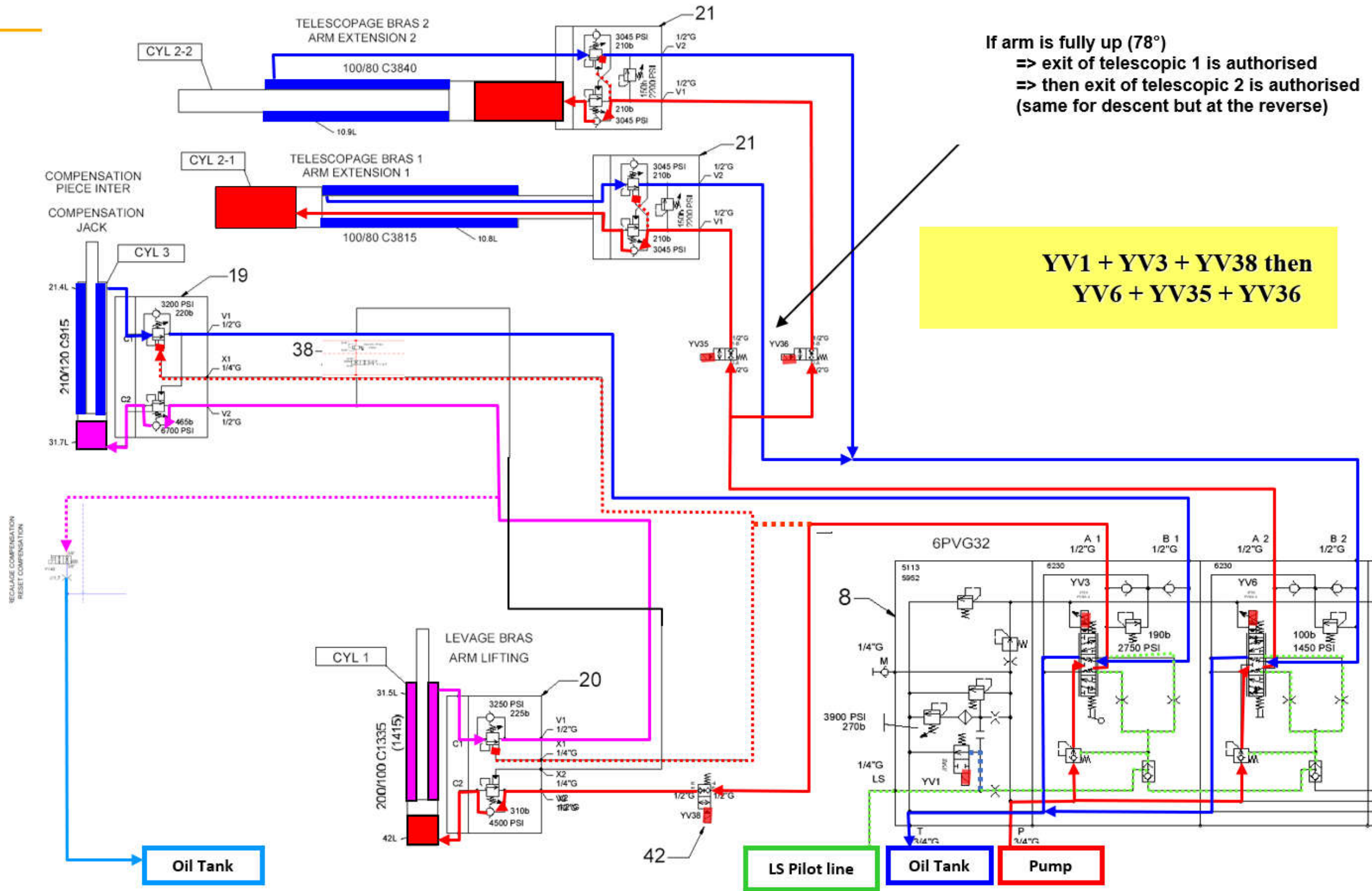

# MAIN BOOM DESCENT

# RELEVAGE FLECHE BOOM LIFT

The descent is securized by YV42 (no engine cut out if working zone is overlapped)

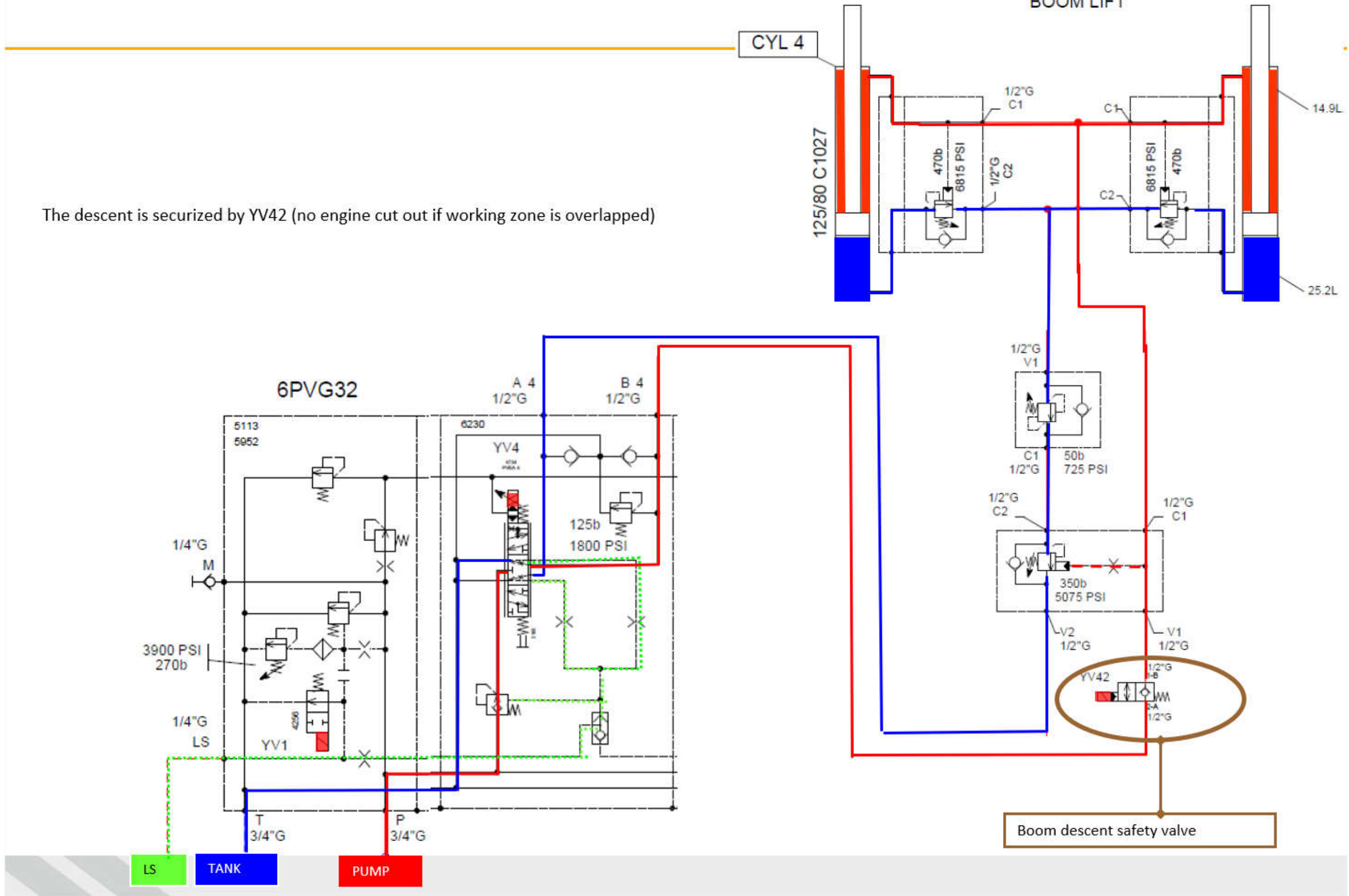



## TELESCOPIC BOOM EXTENSION

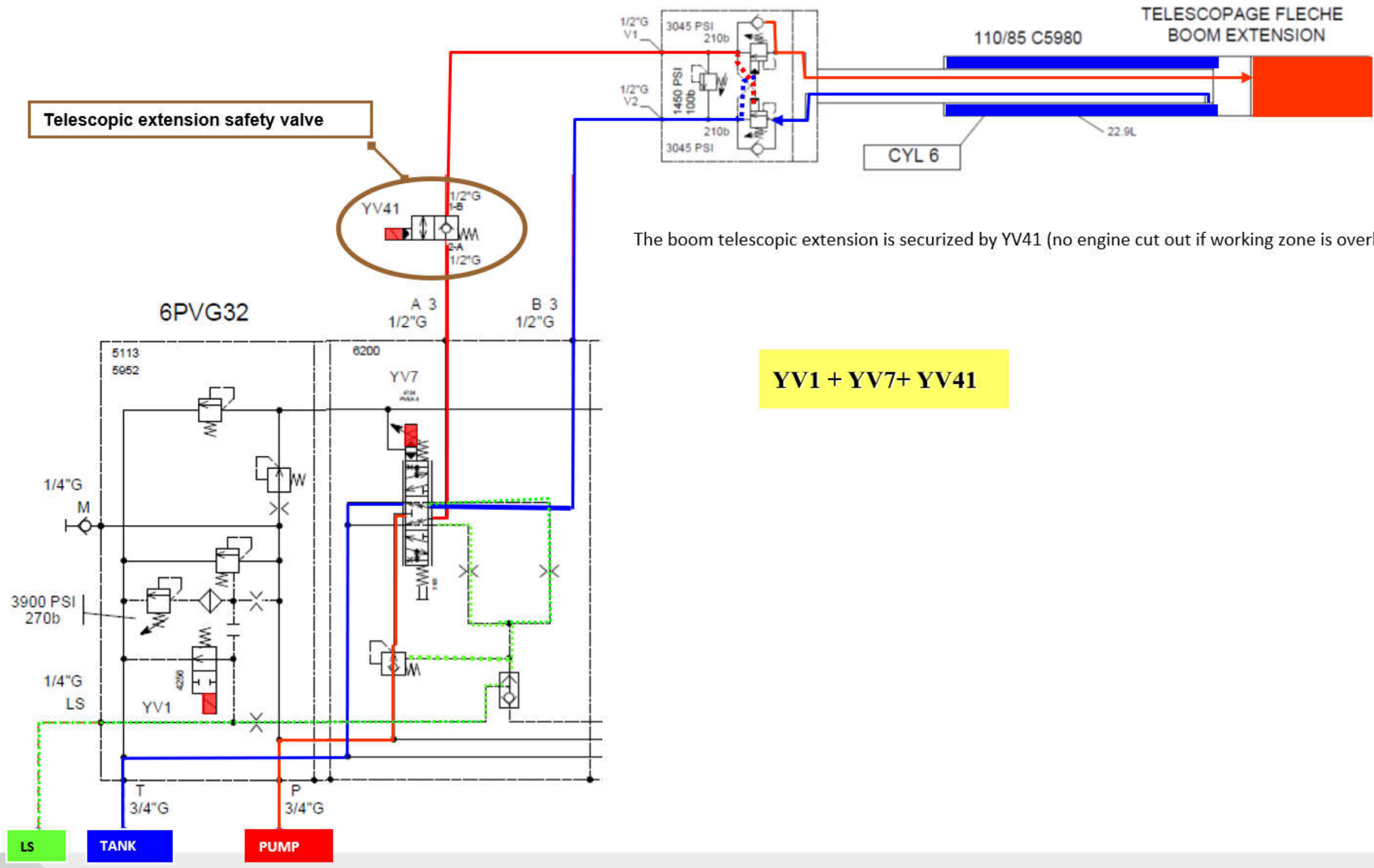

The boom telescopic extension is securized by YV41 (no engine cut out if working zone is overlapped)

**YV1 + YV7+ YV41**

# BOOM DESCENT

**YV1 + YV4 + YV42**

Piloted valve used to avoid boom descent in case of desynchronisation between the 2 cylinders  
 Piloted valve for boom descent in order to hold the load

RELEVAGE FLECHE  
BOOM LIFT

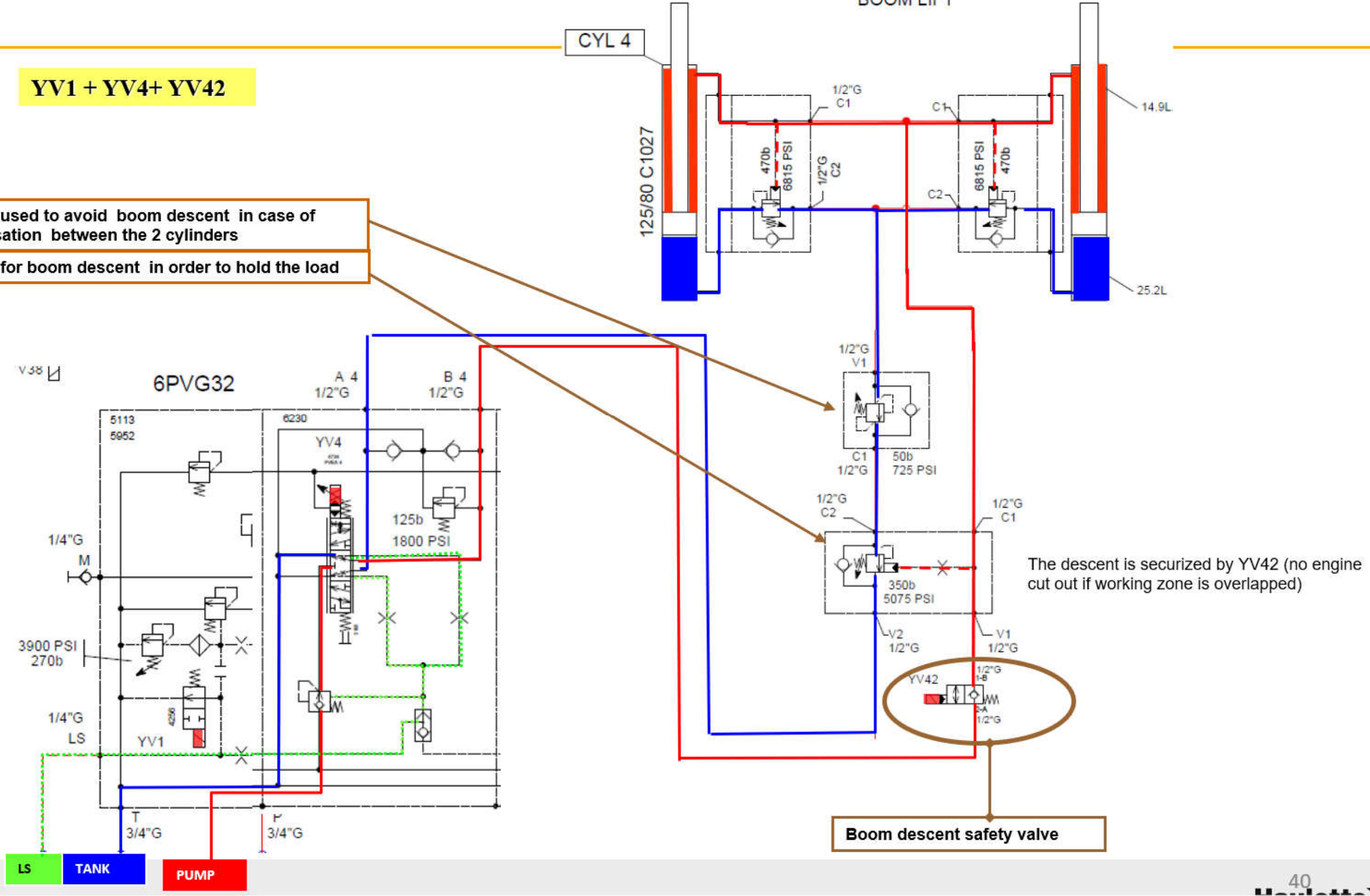

## TURNTABLE ROTATION

**YV1 + YV5+YV34**

Cut the circuit during movement in order to avoid unexpected movement due to some remaining pressure in the circuit

ORIENTATION TOURELLE  
TURRET SLEWING

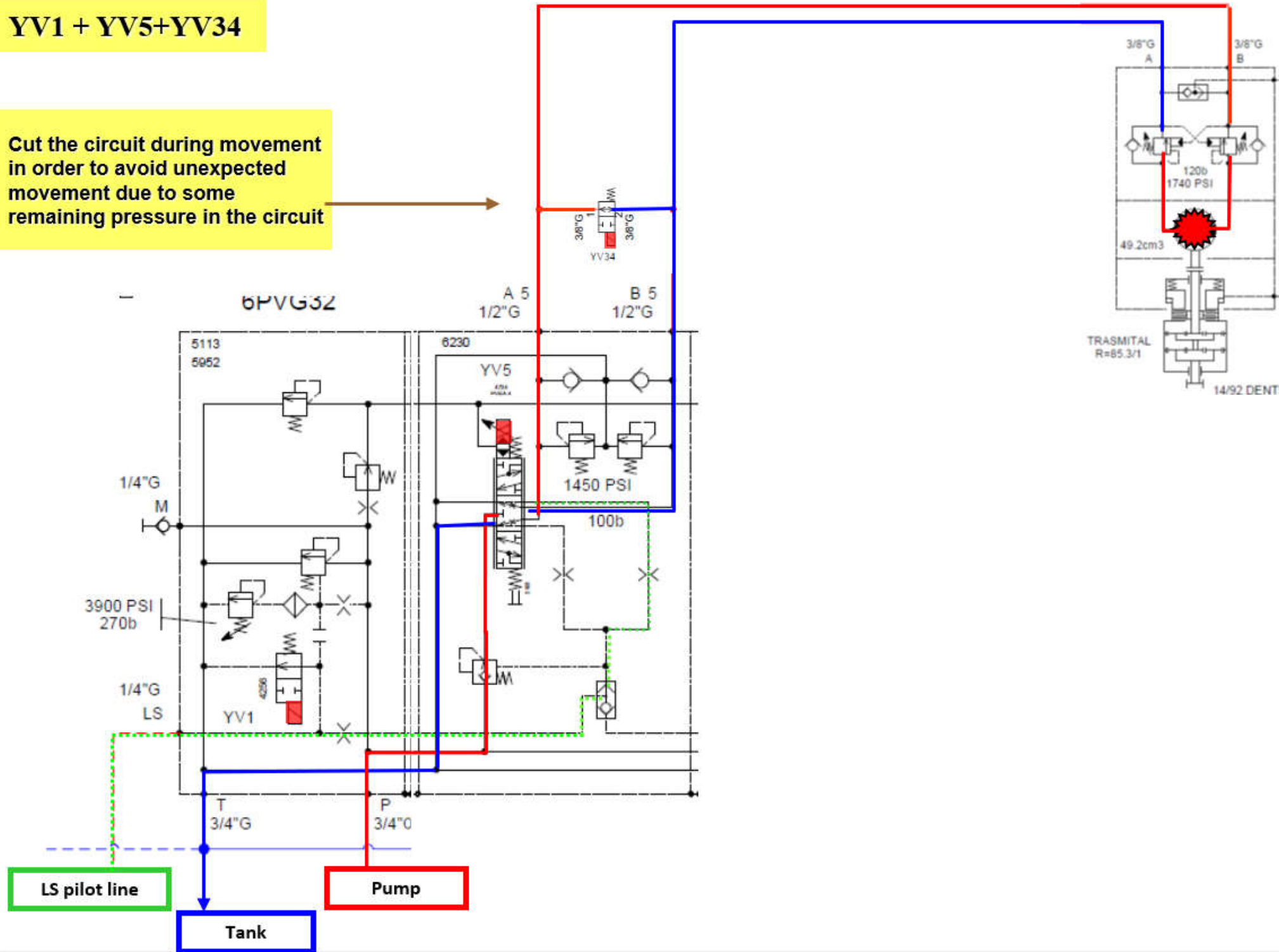



# BASKET COMPENSATION

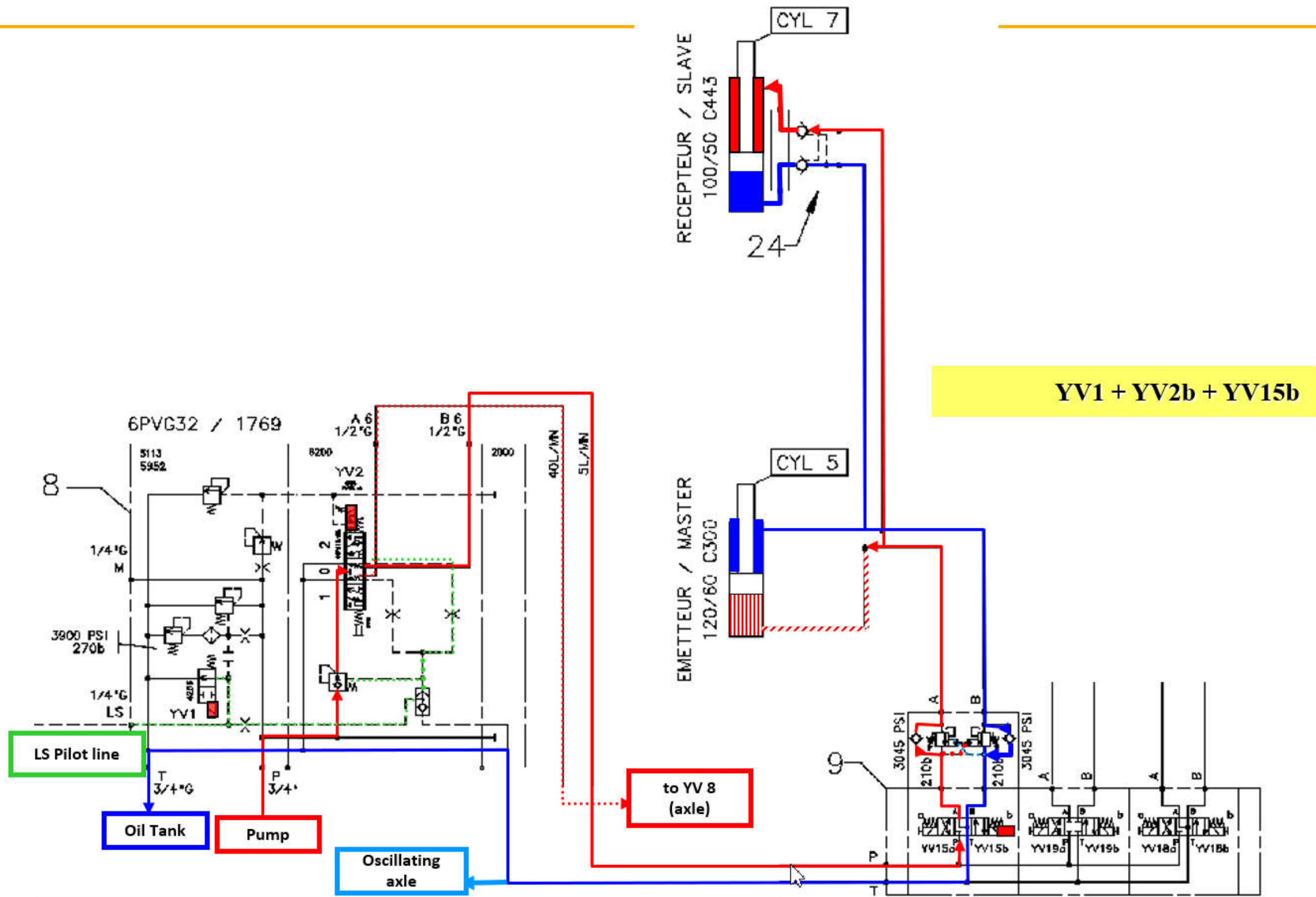



# BASKET ROTATION

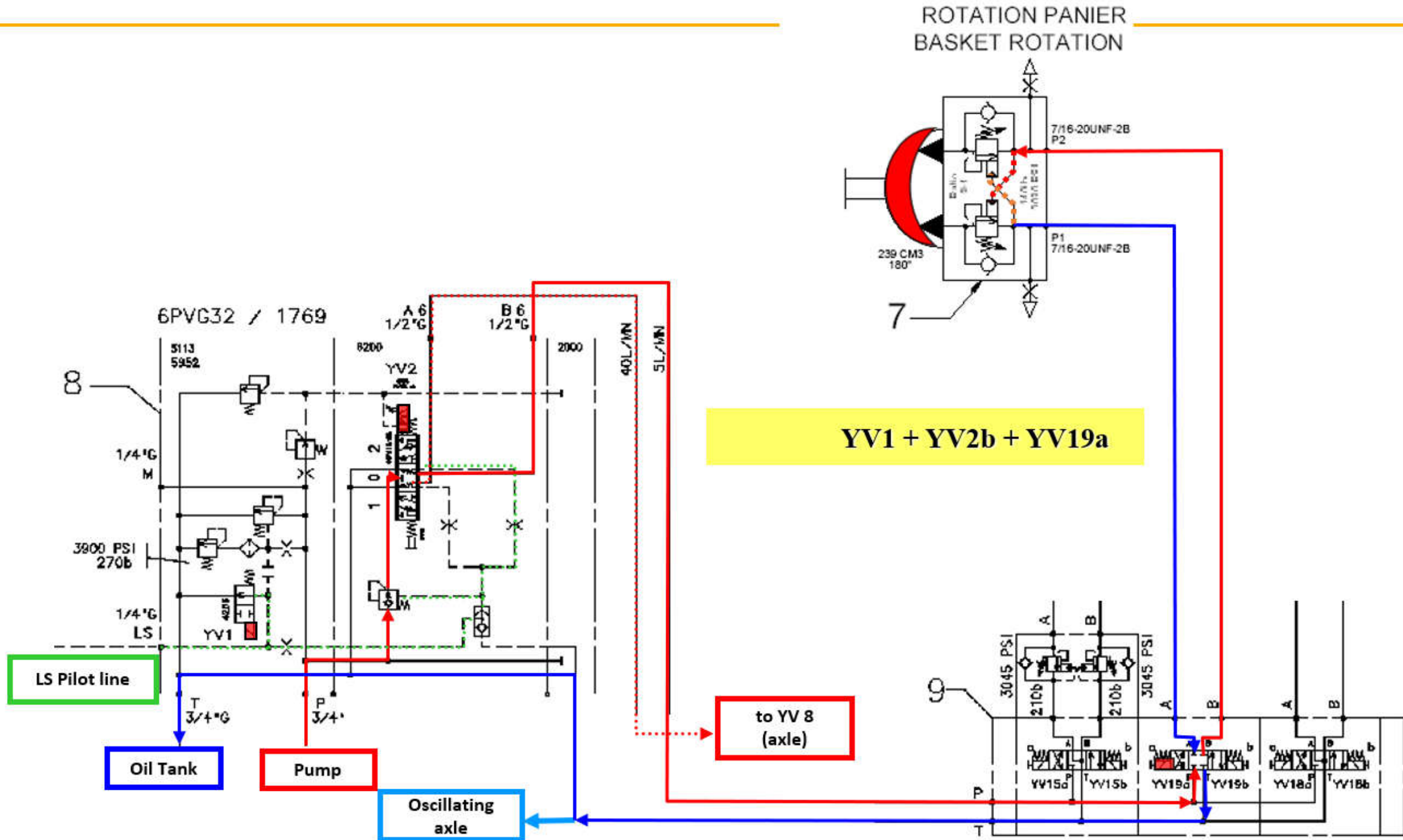

**YV1 + YV2b + YV19a**

to YV 8  
(axle)

# JIB LIFTING

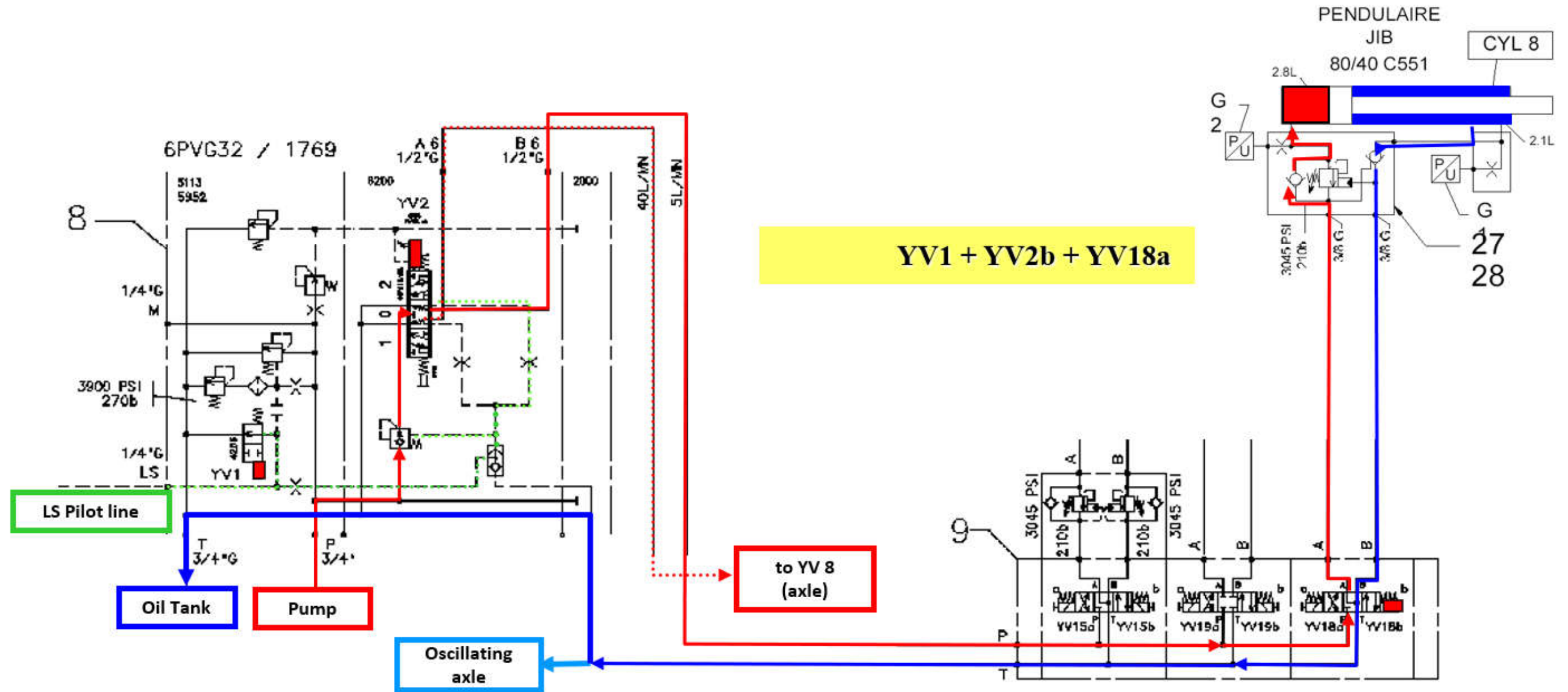

**10.2. ELECTRICAL FUNCTION 159P319780**

**ENGINE CIRCUIT FOLIO 01/08**

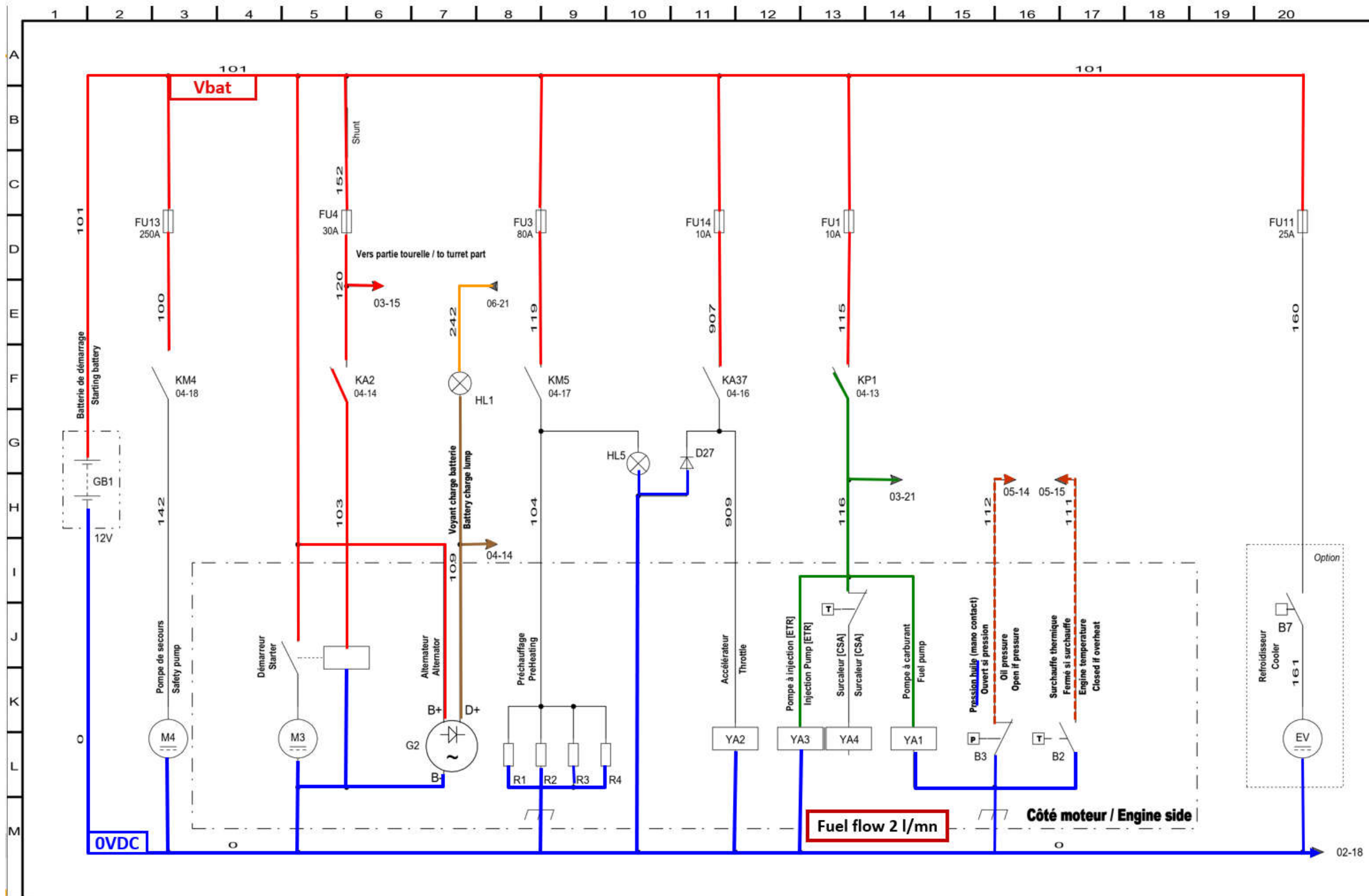



# CHASSIS CIRCUIT FOLIO 02/08

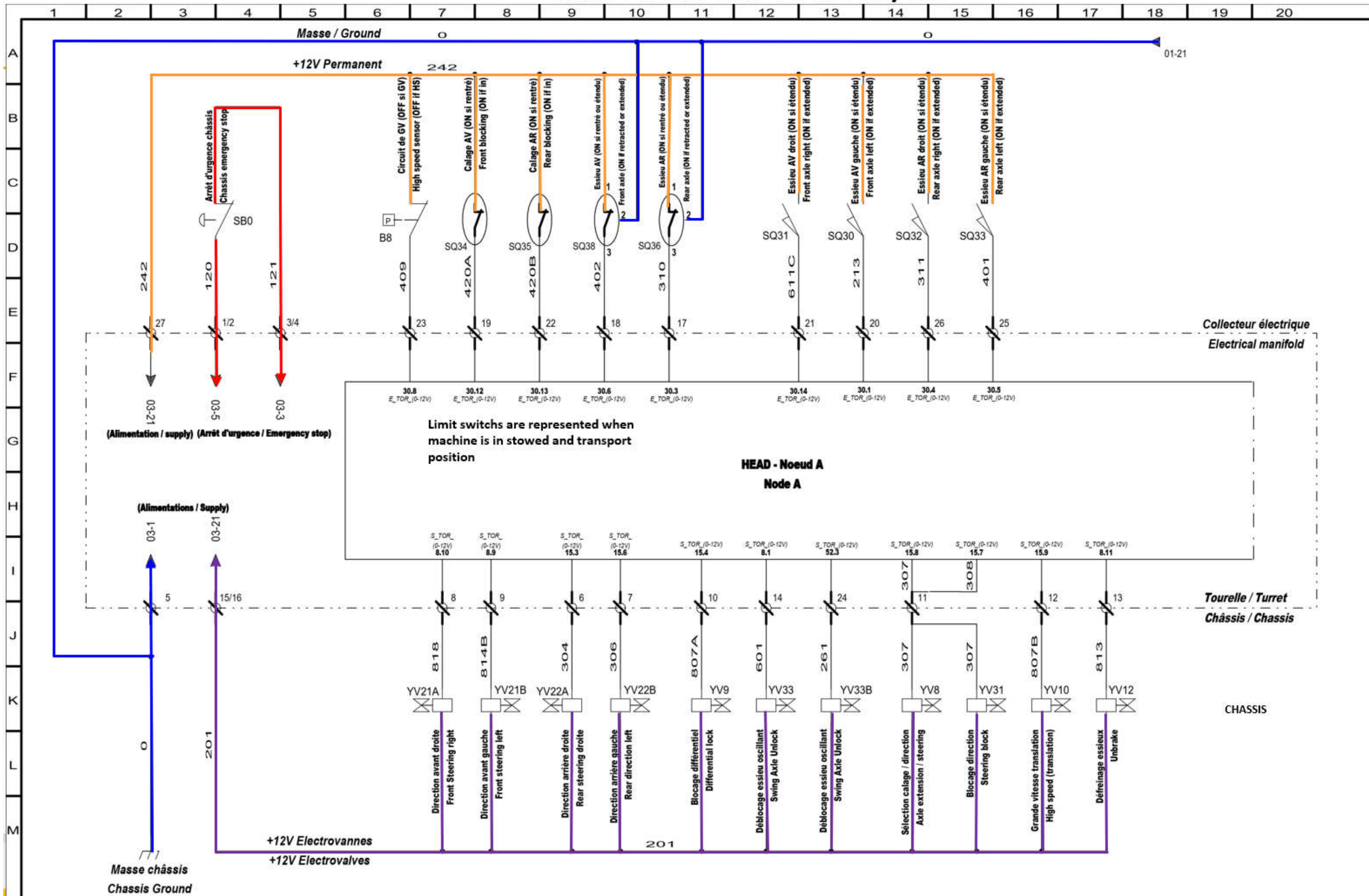



# TURRET CIRCUIT FOLIO 03/08

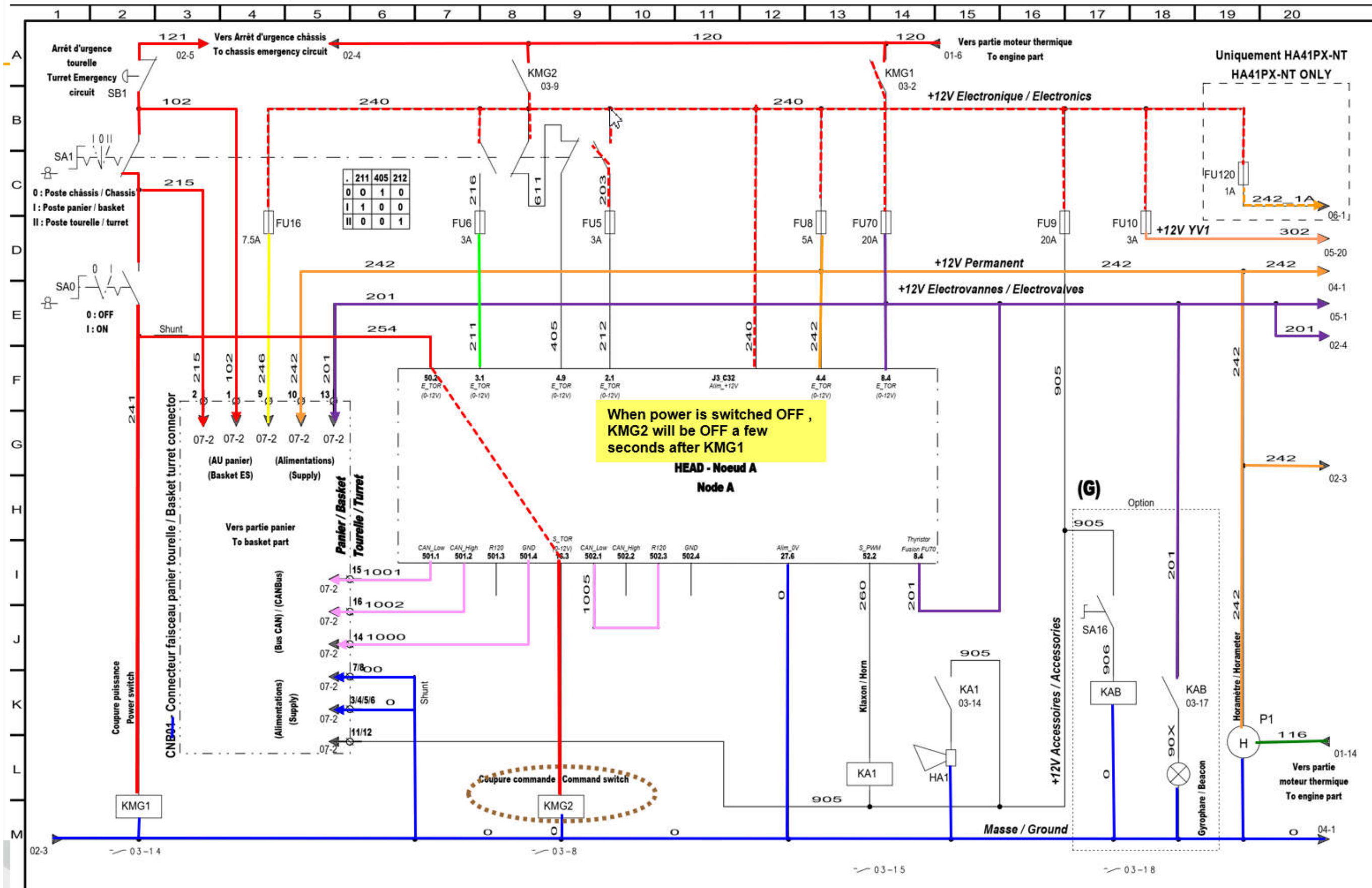

# TURRET CIRCUIT FOLIO 04/08

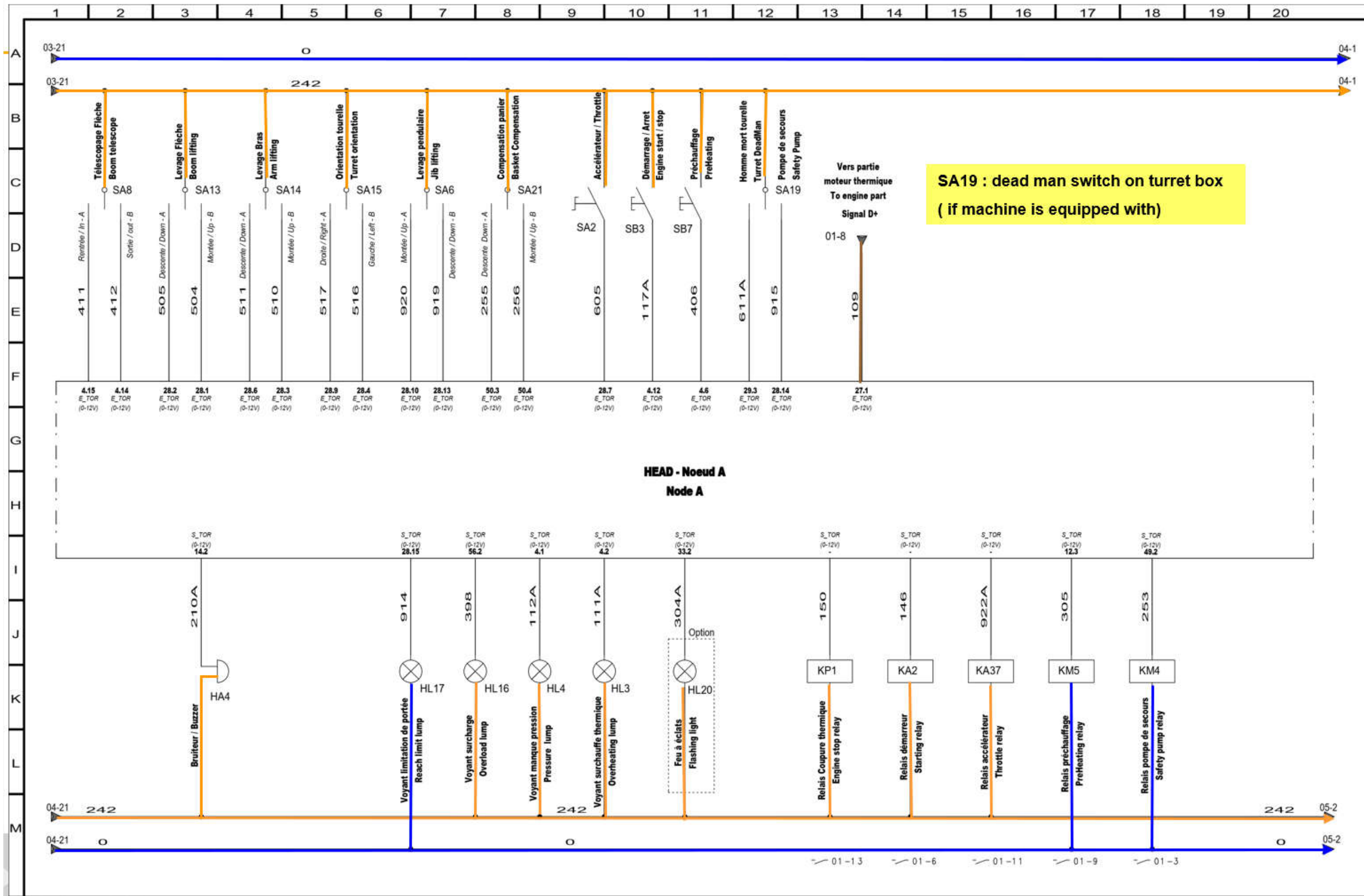

# TURRET CIRCUIT FOLIO 05/08

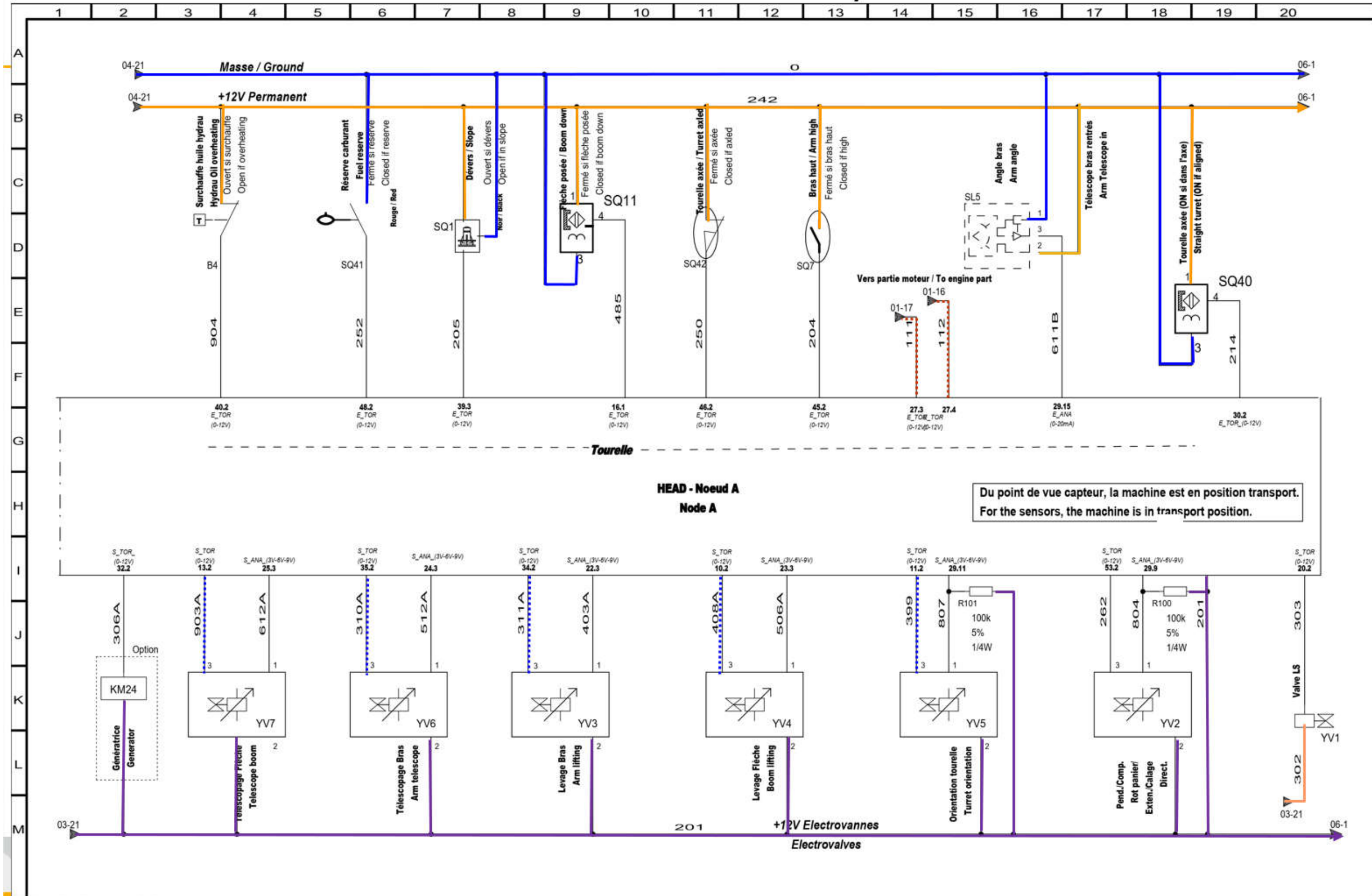



# TURRET CIRCUIT FOLIO 06/08

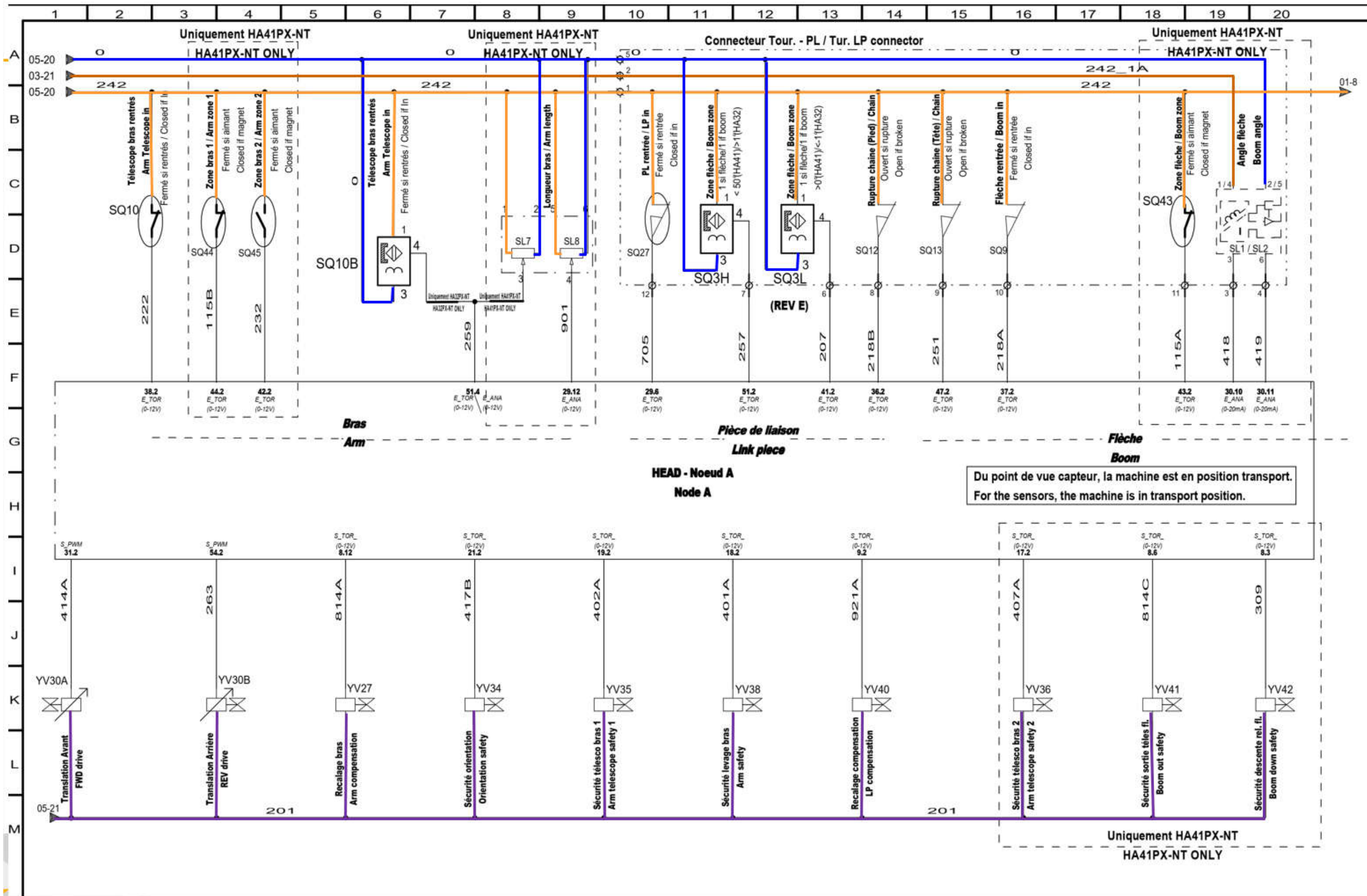



# BASKET CIRCUIT FOLIO 07/08

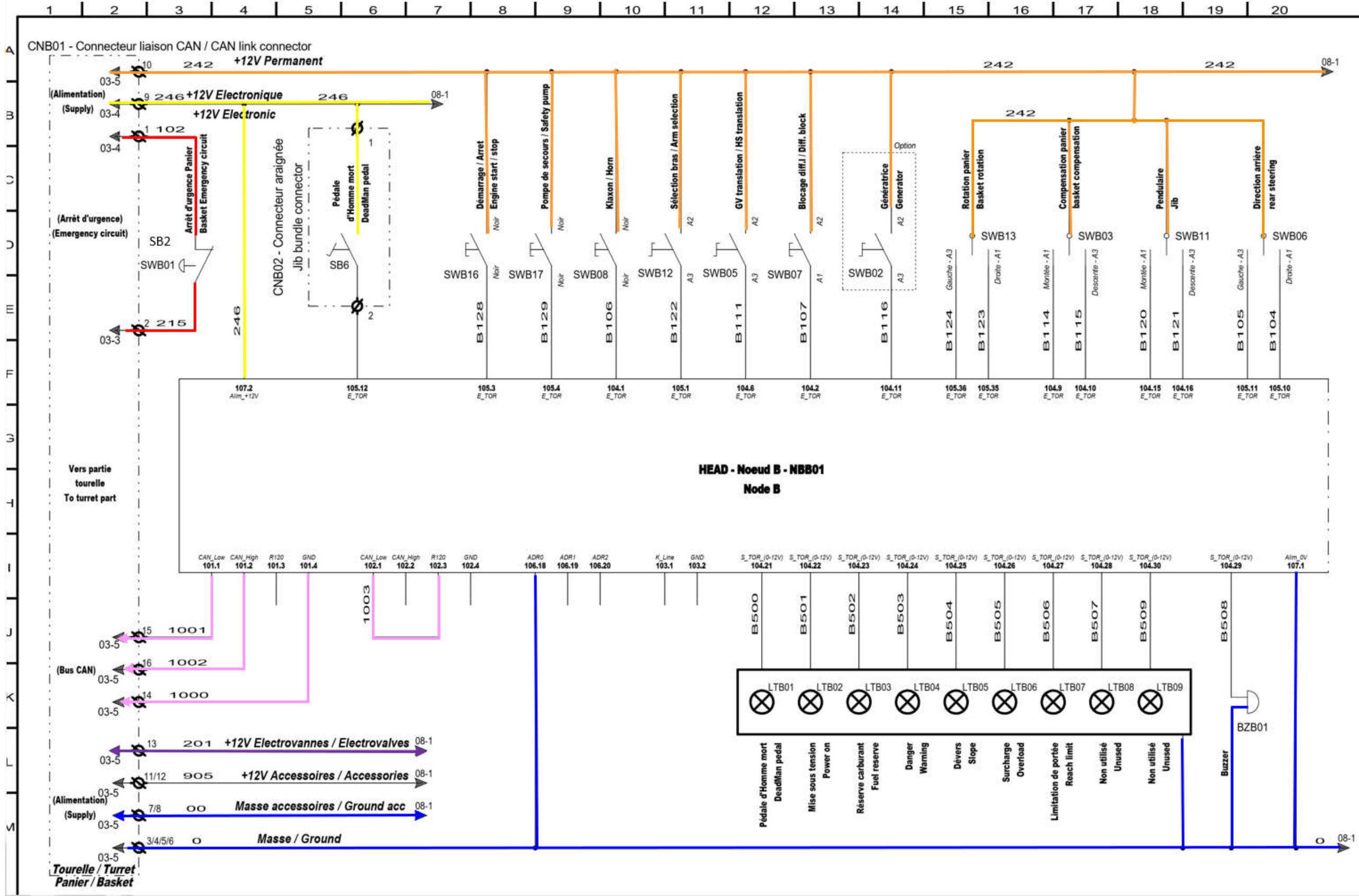

# BASKET CIRCUIT FOLIO 08/08

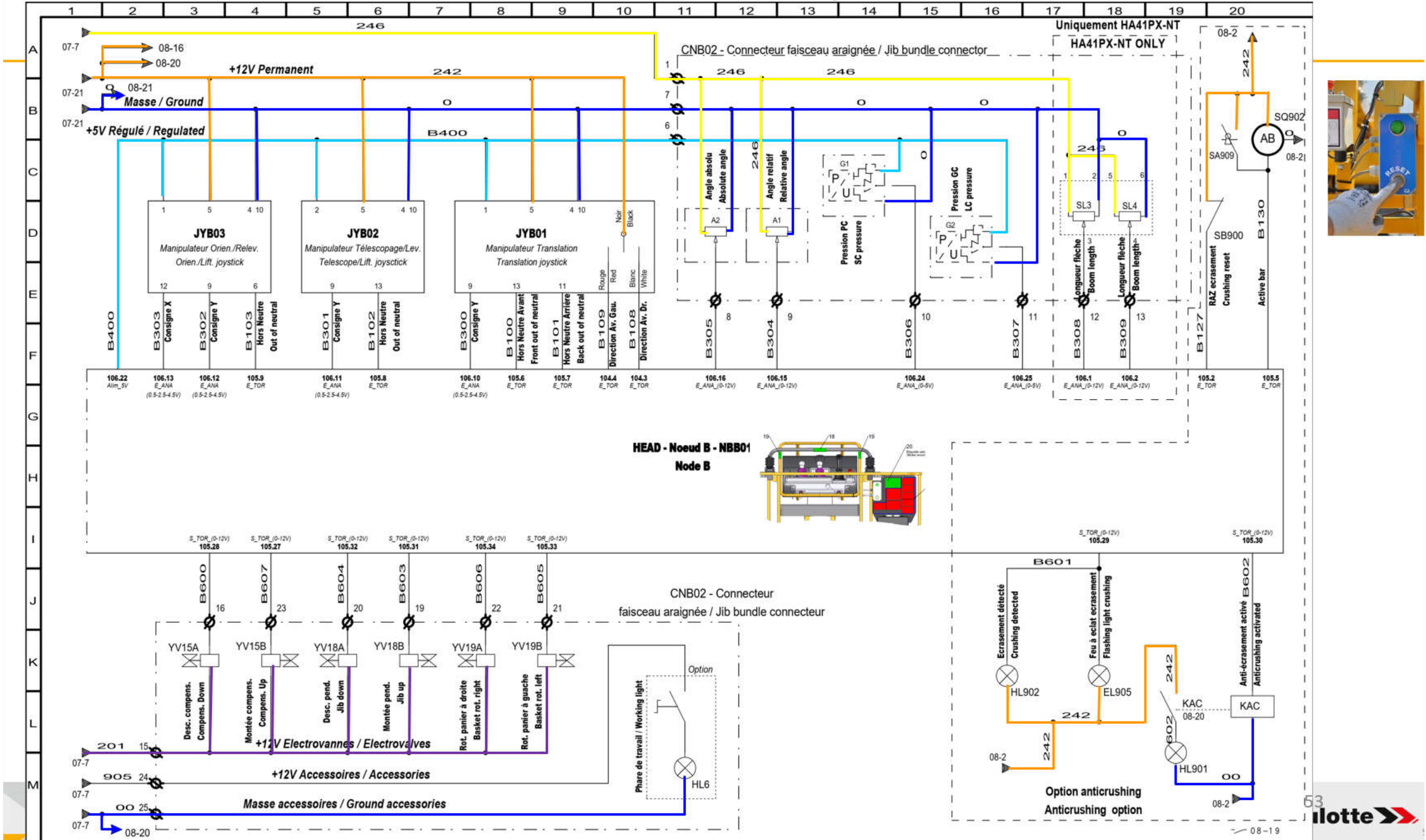



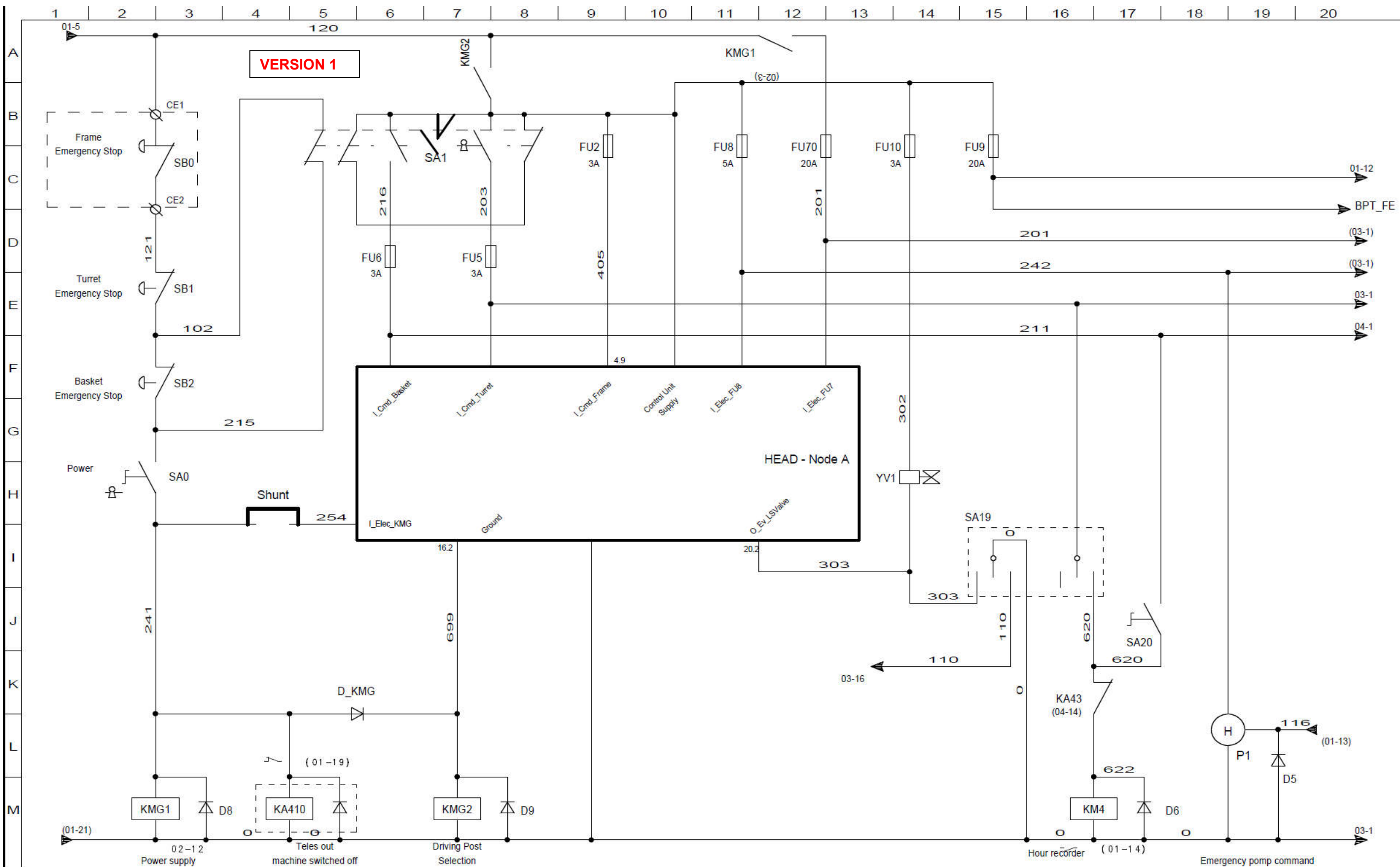

 La Péronnière BP 9 42152 L'HORME TEL: 04 77 29 24 24	DESSINE PAR B.Pallot	DATE DE CREATION 07/04/2005	HA41PX	MODIF HBA	IND D	DATE 10/07/2009	MODIFICATION Ajout KMG2	VISA B.Pallot	NBR TOTAL DE FOLIOS 06
	VERIFIE PAR F.Lemire	DATE DE VERIFICATION 11/04/2005		MODIF BPT	IND B	DATE 19/09/2006	MODIFICATION	VISA HBA	
								BPT	

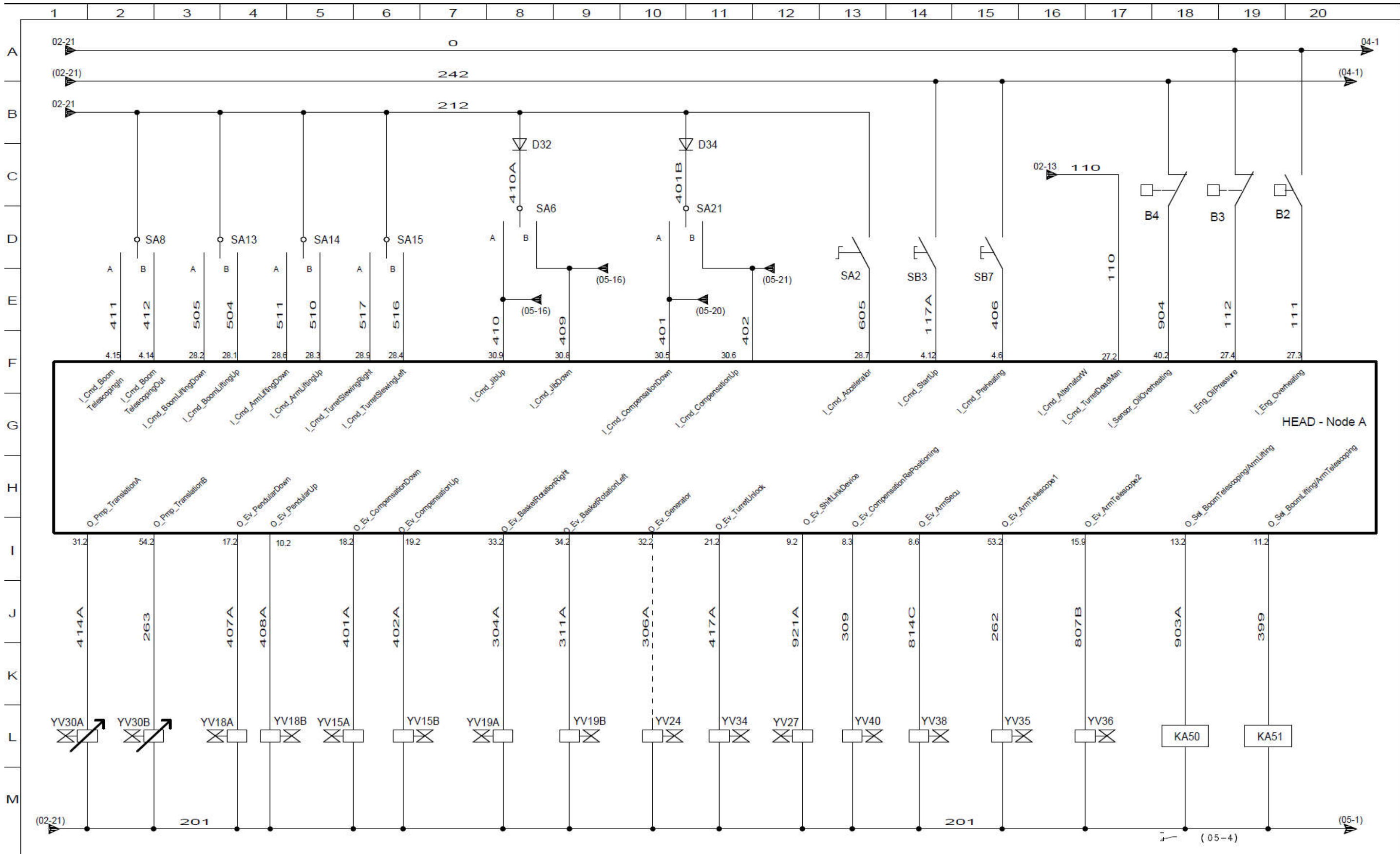



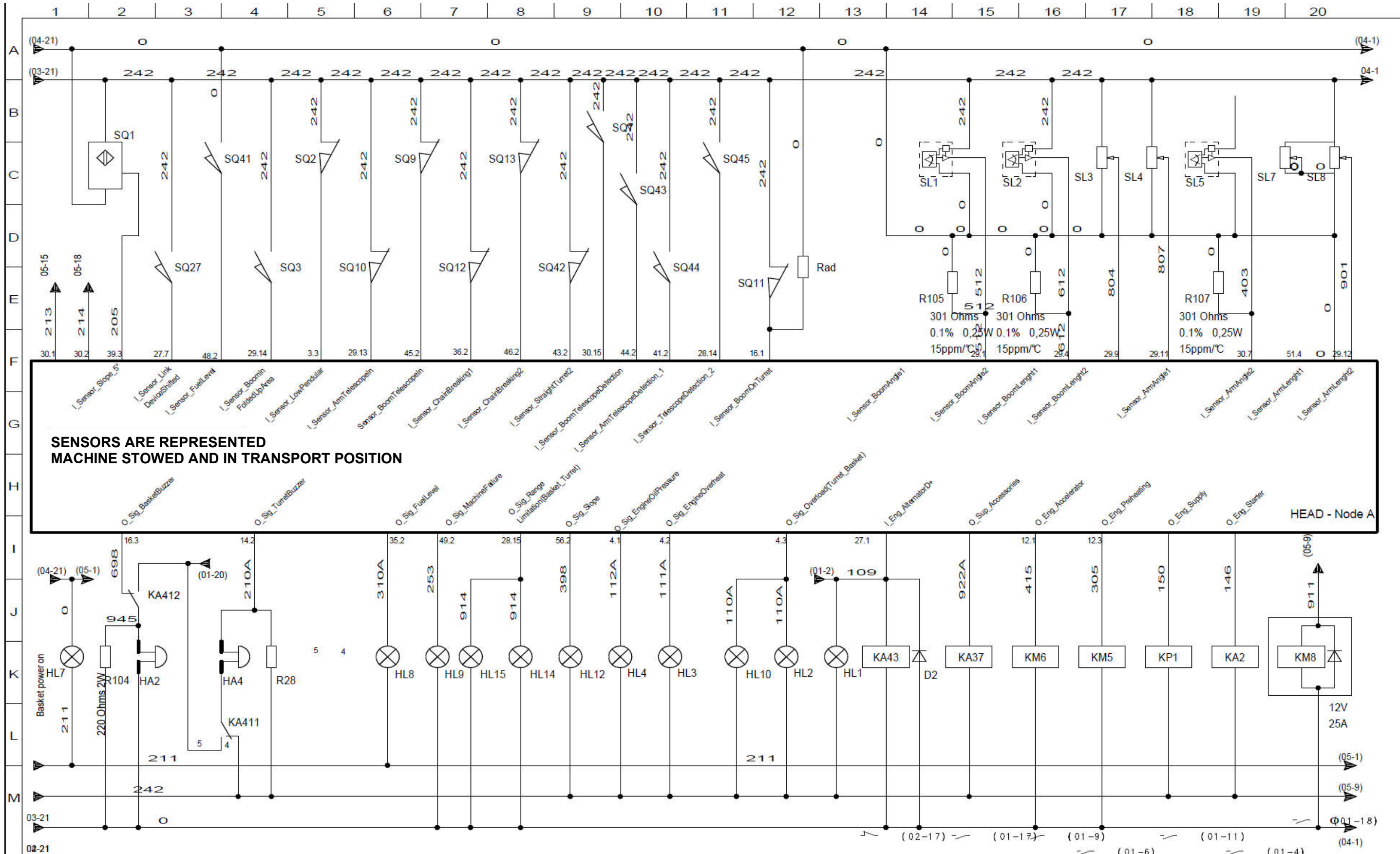

DESSINE PAR B.Pallot	DATE DE CREATION 07/04/2005
VERIFIE PAR F.Lemire	DATE DE VERIFICATION 11/04/2005

HA41PX	
--------	--

MODIF	IND	DATE	MODIFICATION	VISA
D		10/07/2009	ajout SQ27	
B		19/09/2006		BPT

NBRE TOTAL DE FOLIOS 06	<b>SCHEMAS</b>	<b>04</b>
----------------------------	----------------	-----------

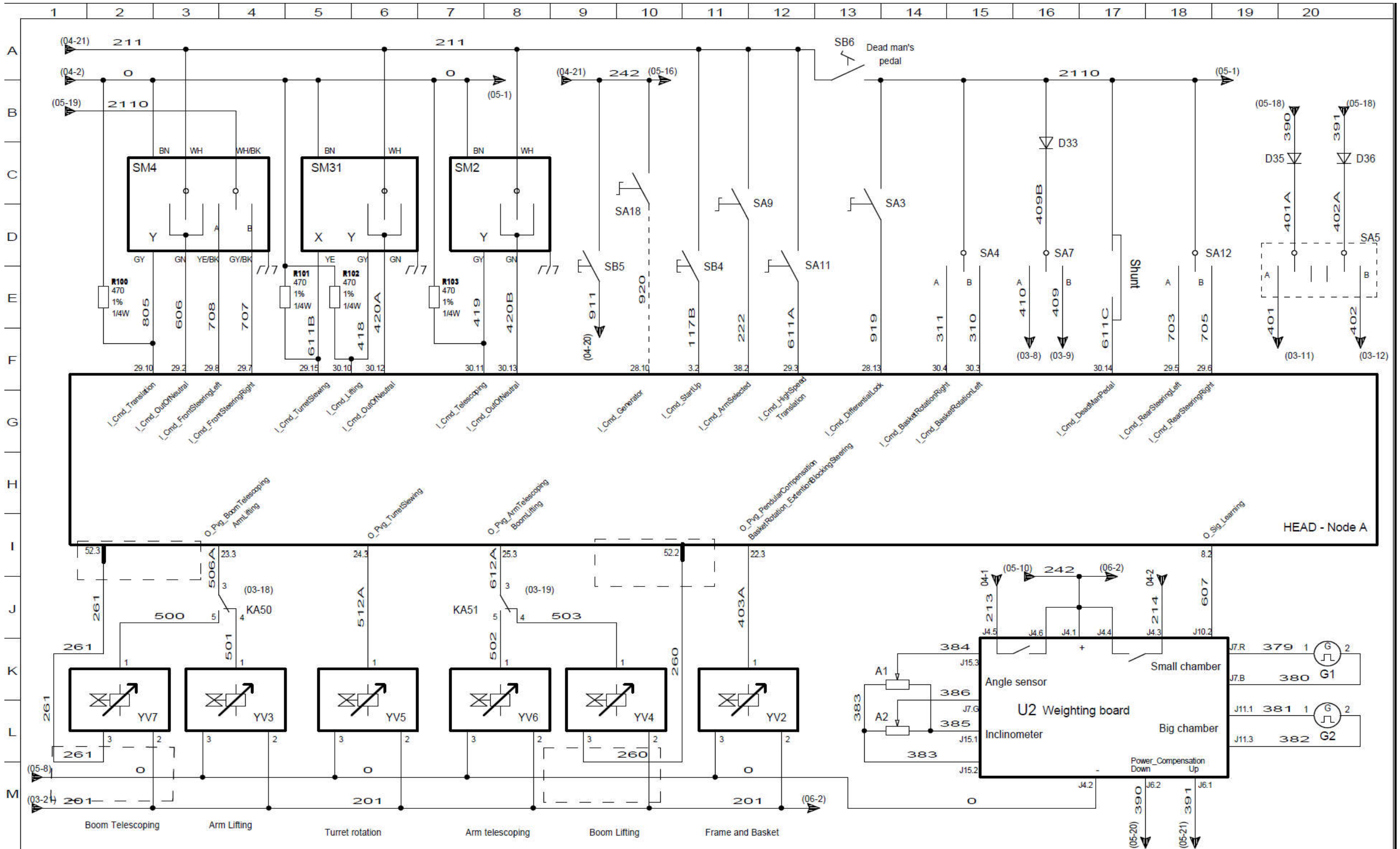



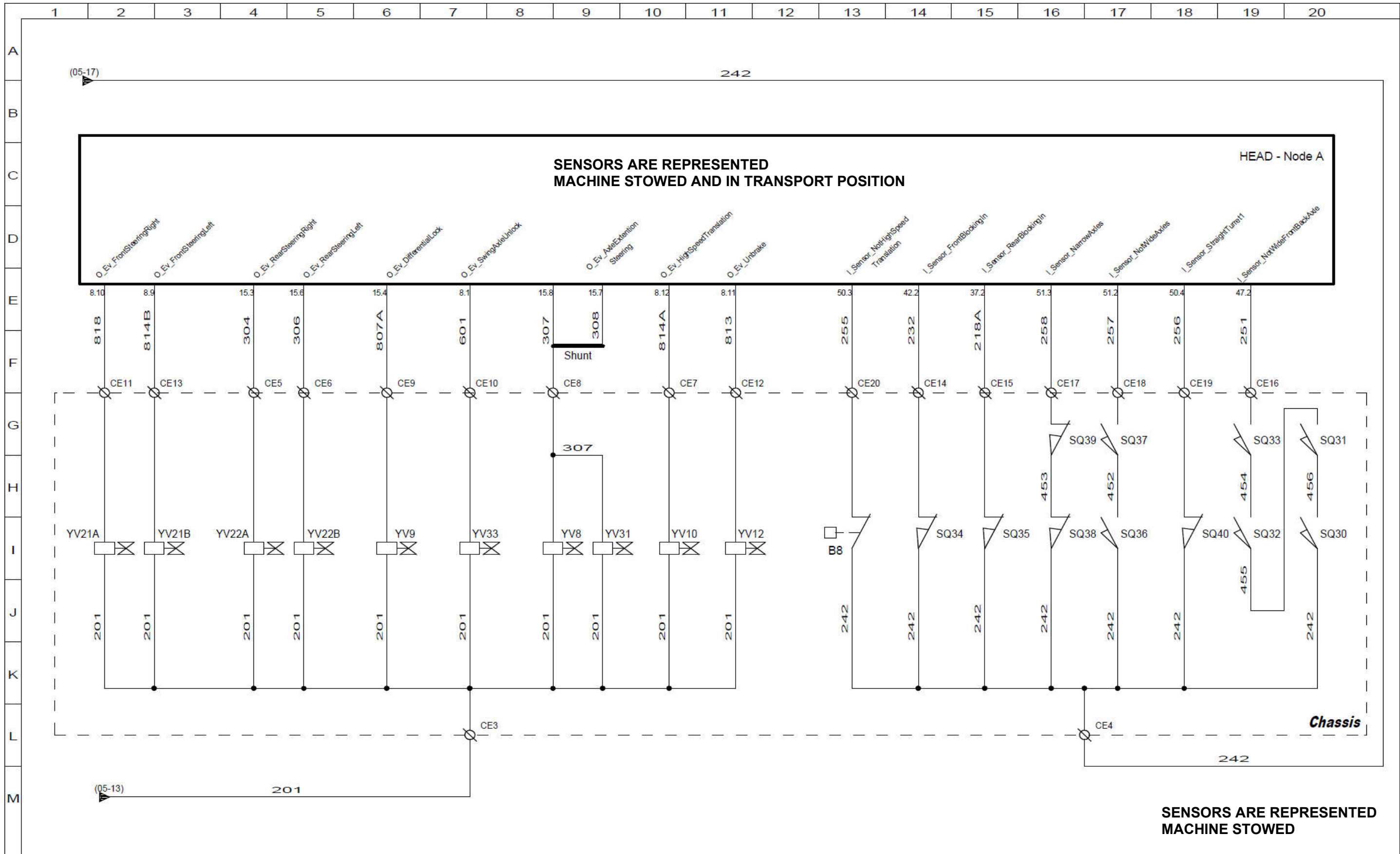

 La Péronnière BP 9 42152 L'HORME TEL: 04 77 29 24 24	DESSINE PAR B.Pallot	DATE DE CREATION 07/04/2005	HA41PX	MODIF	IND	DATE	MODIFICATION	VISA	NBRE TOTAL DE FOLIOS 06
	VERIFIE PAR F.Lemire	DATE DE VERIFICATION 11/04/2005							SCHEMAS

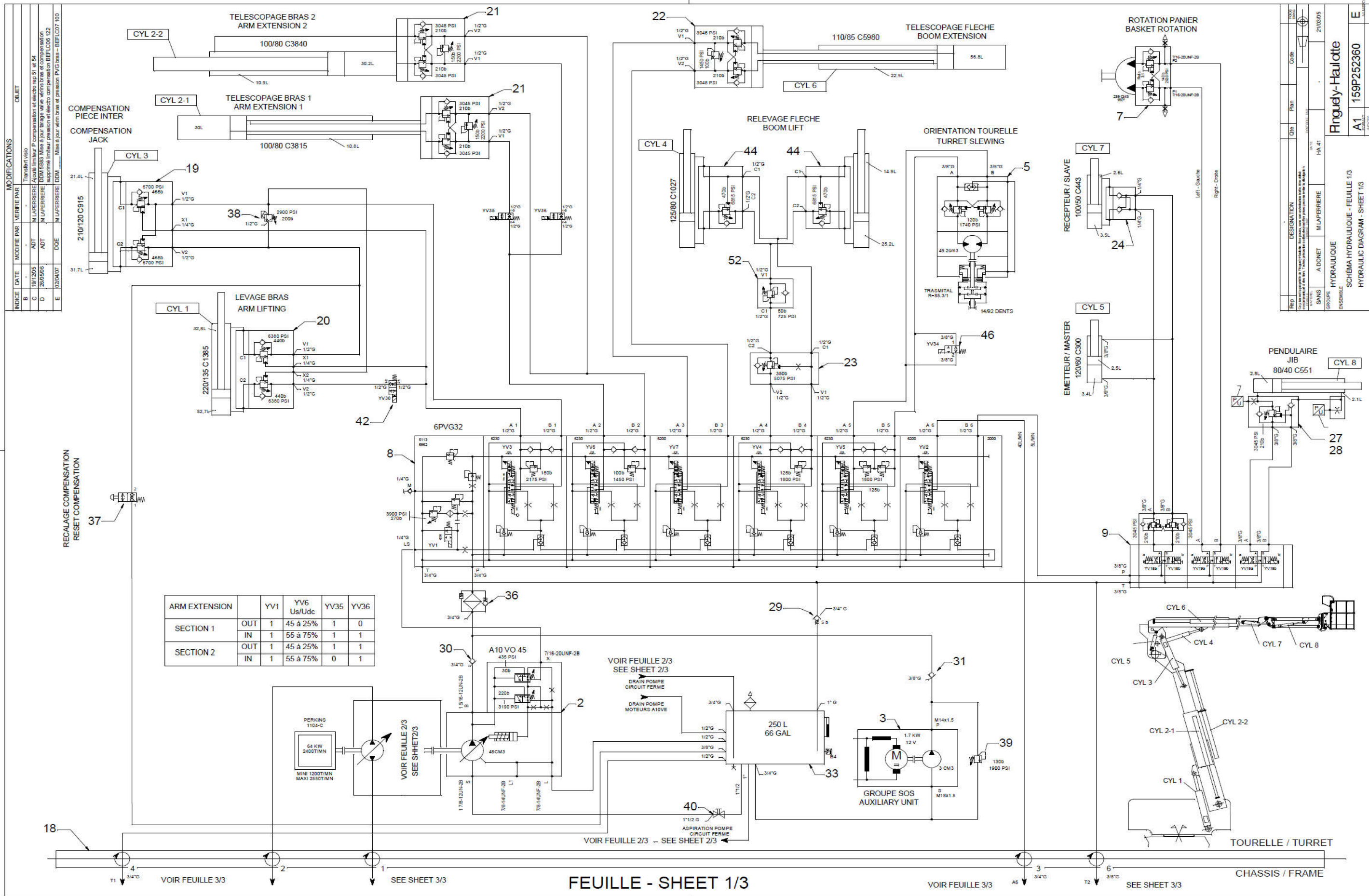

ARM EXTENSION		YV1	YV6 Us/Udc	YV35	YV36
SECTION 1	OUT	1	45 à 25%	1	0
	IN	1	55 à 75%	1	1
SECTION 2	OUT	1	45 à 25%	1	1
	IN	1	55 à 75%	0	1

**INDEXE DATE MODIFIE PAR VERIFIE PAR OBJET**

B - 19/12/05 MLAPERRIERE ADT Transfert visio

C - 28/05/06 MLAPERRIERE ADT DDM 5583 Mise à jour large valve, vannes bras et compensation

D - 02/04/07 MLAPERRIERE DDM Mise à jour limiteur pression et électro compensation BFLC001 122

E - 02/04/07 MLAPERRIERE DDM Mise à jour vrm bras et pression PVG bras - BFLC007 100

**DESIGNATION**  
HA 41

**PROJET**  
HA 41

**GROUPES**  
A DONNET MLAPERRIERE

**ENSEMBLE**  
HYDRAULIQUE

**SCHEMA HYDRAULIQUE - FEUILLE 1/3**

**A1 159P252360**

**E**



MODIFICATIONS		
INDICE	DATE	MODIFIE PAR
B	19/12/05	M LAPERRIERE
C	28/05/06	ADT
D	02/04/07	DOE
E		

OBJET  
Transfert visio  
M LAPERRIERE  
Ajouté limiteur P compensation et électro rep 51 et 54  
M LAPERRIERE  
DDM 5883 Mise à jour large valve véris bras et compensation  
supplément in situ pression et électro compensation BEFLC06122  
M LAPERRIERE  
DDM  
Mise à jour véris bras et pression PVG bras - BEFLC07100

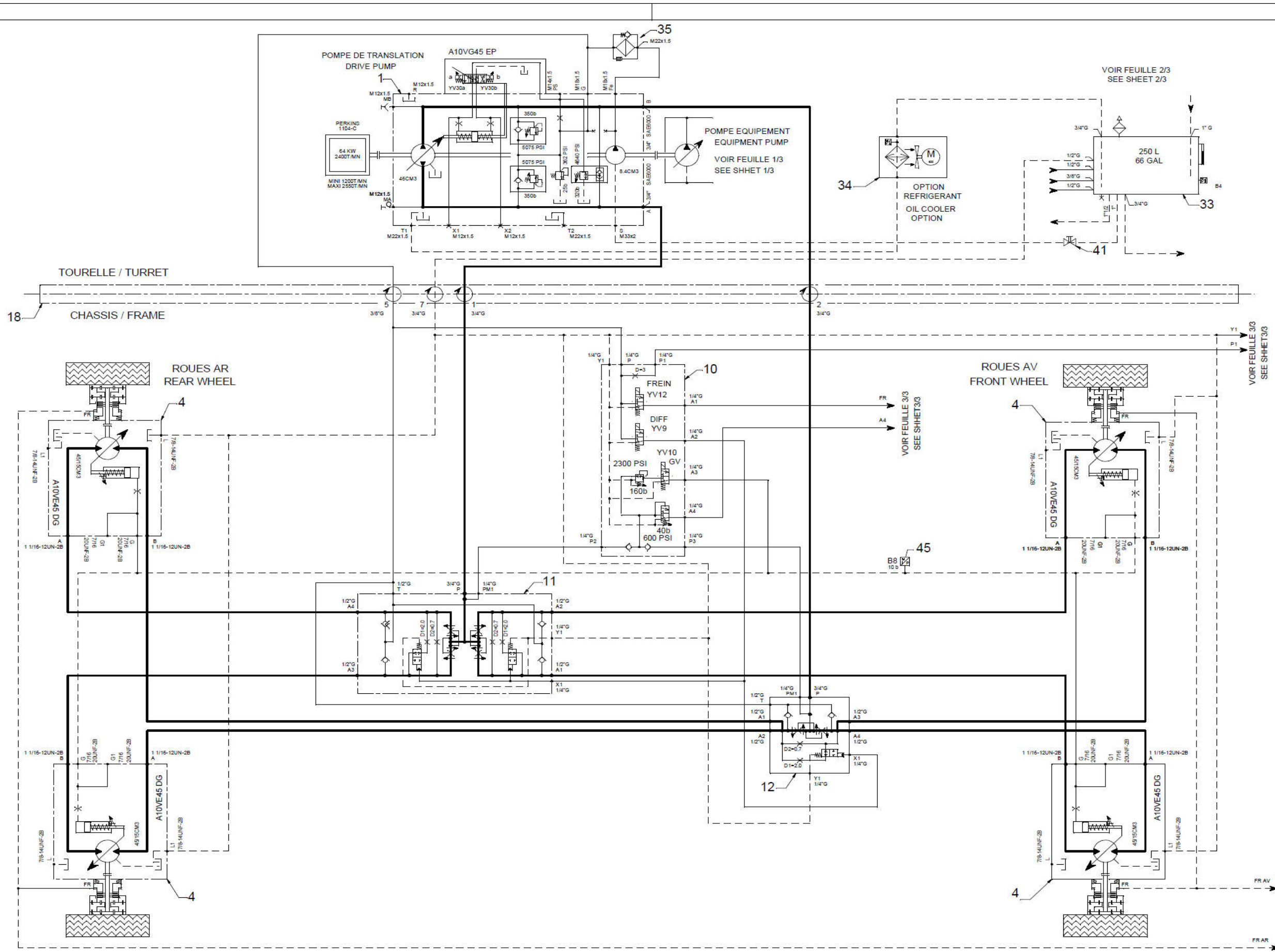

FEUILLE - SHEET 2/3

Rep	DESIGNATION	Code	1500,05
1	TOURELLE	HA 41	
HYDRAULIQUE			
SCHEMA HYDRAULIQUE - FEUILLE 2/3			
HYDRAULIC DIAGRAM - SHEET 2/3			
A1			E
159P252360			

MODIFICATIONS		
INDICE	DATE	MODIFIE PAR / VERIFIE PAR
B	-	-
C	19/12/05	M. LAPERRIERE
D	26/05/06	ADT
E	02/04/07	DOE

OBJET  
Transfert visio  
Ajout limiteur P compensation et electro rep 51 et 54  
DDM 583.3 Mise à jour tarage valve bras et compensation  
supporte limiteur pression et electro compensation BEFL006.122  
DDM 583.3 Mise à jour valve bras et pression PVG bras - BEFL007.100

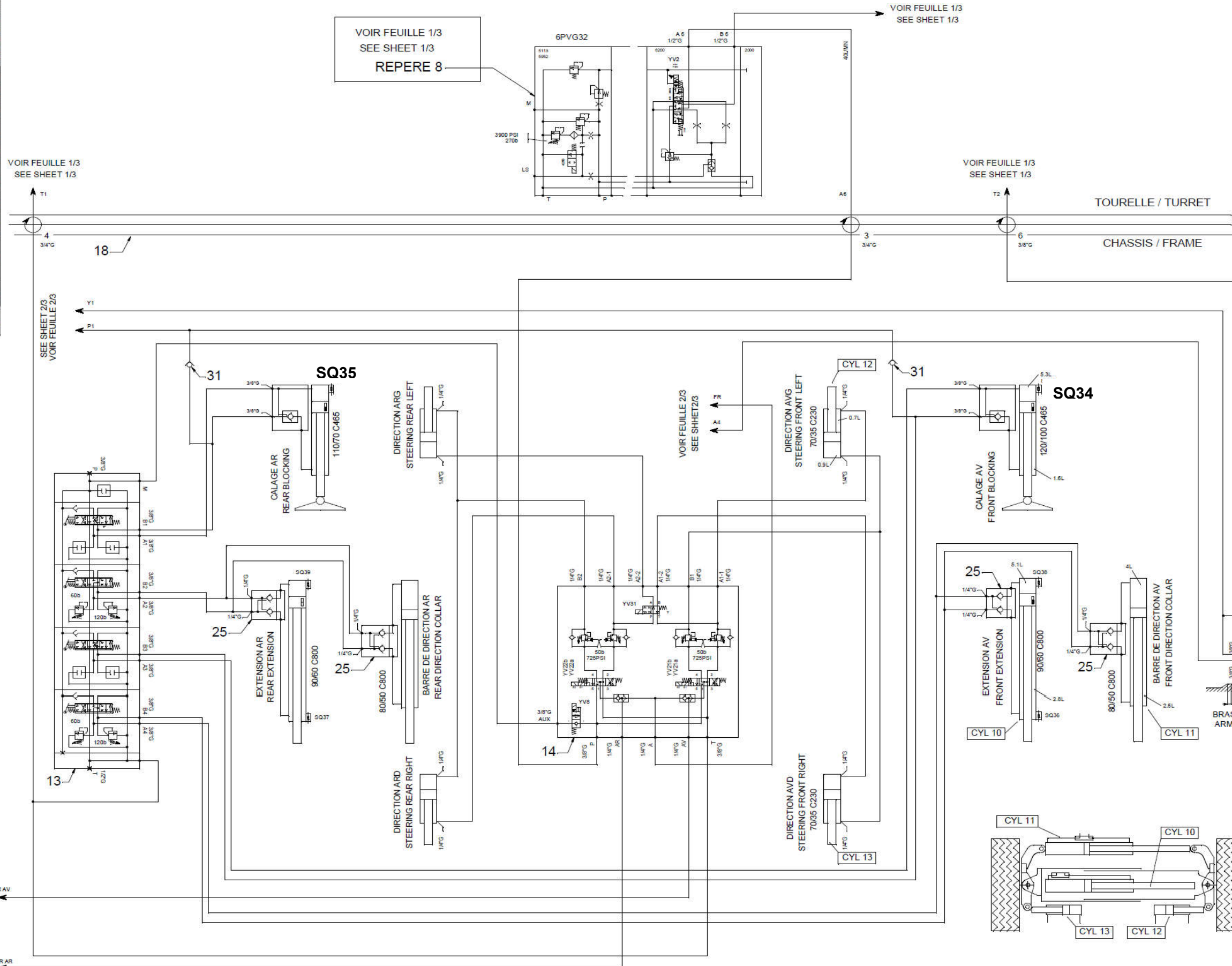

VOIR FEUILLE 1/3  
SEE SHEET 1/3  
REPERE 8

VOIR FEUILLE 1/3  
SEE SHEET 1/3

VOIR FEUILLE 1/3  
SEE SHEET 1/3

VOIR FEUILLE 1/3  
SEE SHEET 1/3

SEE SHEET 2/3  
VOIR FEUILLE 2/3

VOIR FEUILLE 2/3  
SEE SHEET 2/3

FEUILLE - SHEET 3/3

DESIGNATION		QTE	REF	REMARQUE
90/40 C75	ESSEU AV OSCILLANT	1		
90/40 C75	ESSEU AR OSCILLANT	1		

  

REVISION	DATE	DESIGNATEUR	VERIFIEUR	APPROUVE
01		A. DONET	M. LAPERRIERE	HA-41

  

GROUPES	HYDRAULIQUE
REVISIONS	SCHEMA HYDRAULIQUE - FEUILLE 3/3
FORMAT	A1 159P252360
PROJET	E



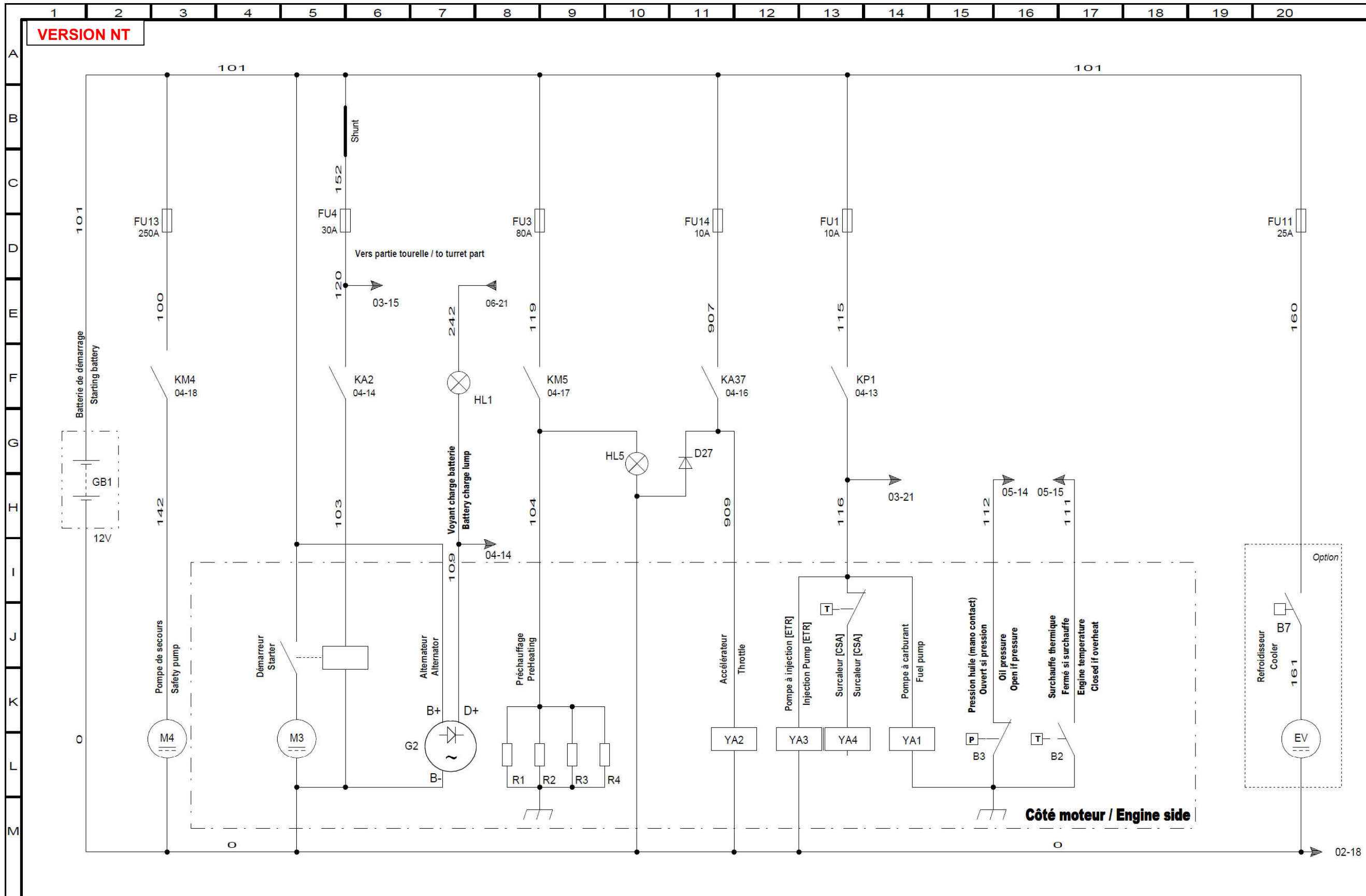

<b>Haulotte</b> <b>GROUP</b> La Péronnière BP 9 42152 L'HORME TEL: 04 77 29 24 24	DESSINE PAR I. Troncy	DATE DE CREATION 18/02/2010	HA32_41PX-NT Partie Moteur - Engine Part 159P319780	MODIF LDF	IND F	DATE 18/07/2013	MODIFICATION Creation anticrushing option	VISA CL	NBRE TOTAL DE FOLIOS 08
	VERIFIE PAR L. Di Florio	DATE DE VERIFICATION 18/02/2010		LDF	IND E	DATE 12/11/2012	MODIFICATION invert pin SQ3H/L	VISA ITR	
				LDF	IND D	DATE 06/06/2012	MODIFICATION capteurs panier sur 246	VISA ITR	159P319780
				LDF	IND C	DATE 26/03/2012	MODIFICATION cablage pedale. MAJ/rq SAV	VISA ITR	

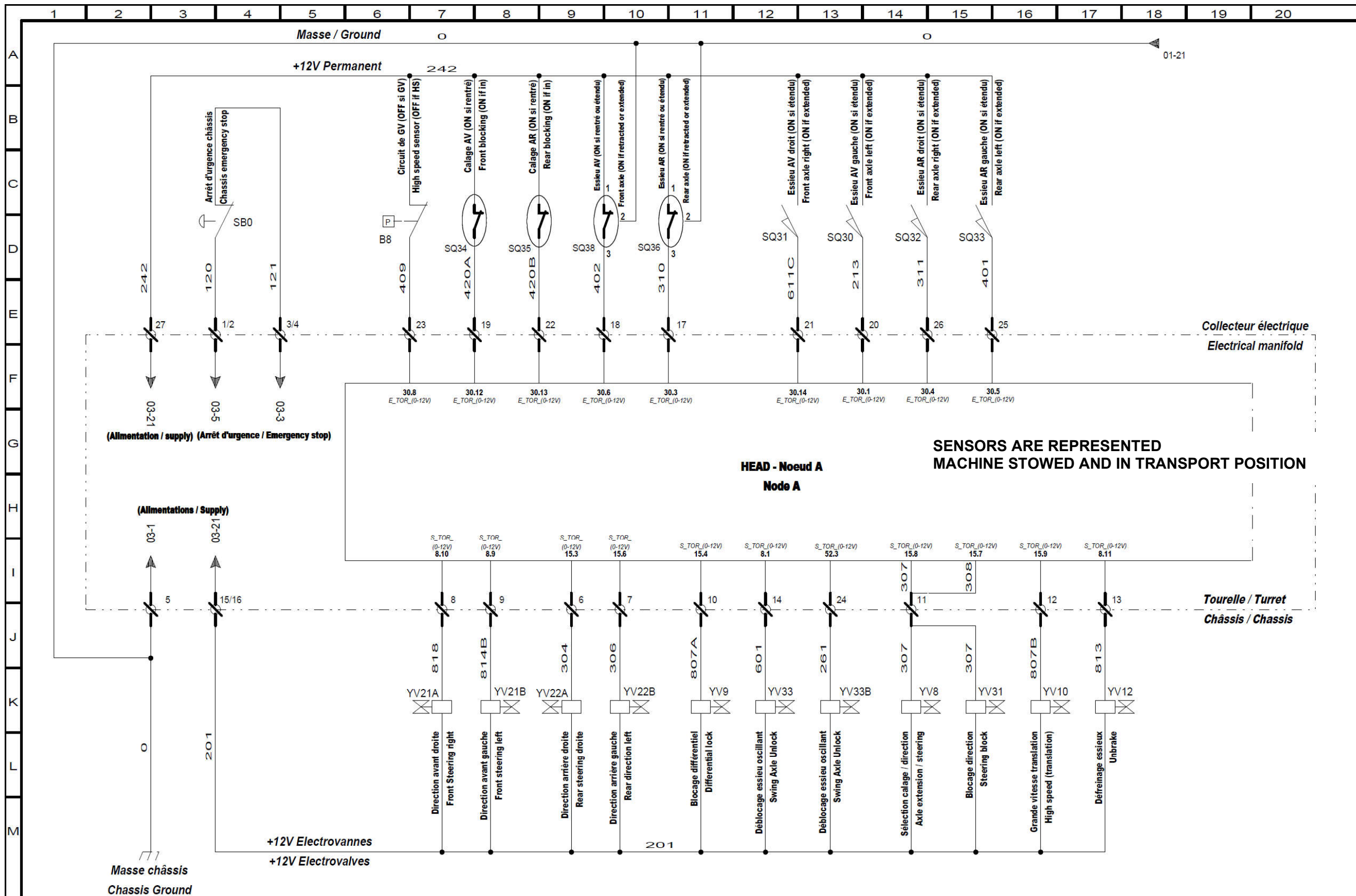

**SENSORS ARE REPRESENTED  
MACHINE STOWED AND IN TRANSPORT POSITION**



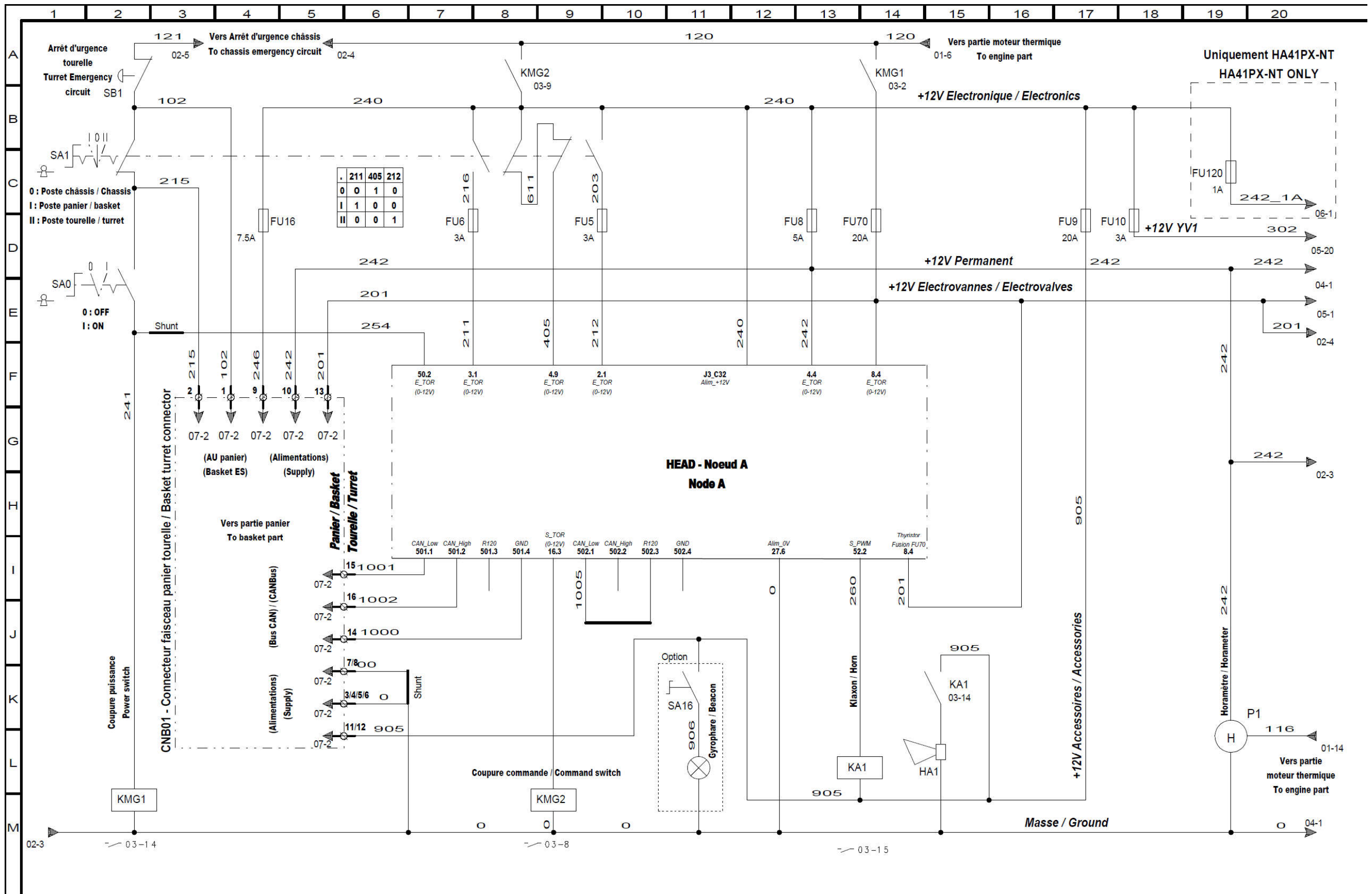

·	211	405	212
0	0	1	0
I	1	0	0
II	0	0	1

**Haulotte**  
GROUP  
La Péronnière  
BP 9 42152 L'HORME TEL: 04 77 29 24 24

DESSINE PAR  
I. Troncy  
DATE DE CREATION  
18/02/2010

VERIFIE PAR  
L. Di Florio  
DATE DE VERIFICATION  
18/02/2010

HA32\_41PX-NT  
Partie Tourelle - Turret Part  
159P319780  
F

MODIF	IND	DATE	MODIFICATION	VISA	NBRE TOTAL DE FOLIOS
					08
					159P319780
					03

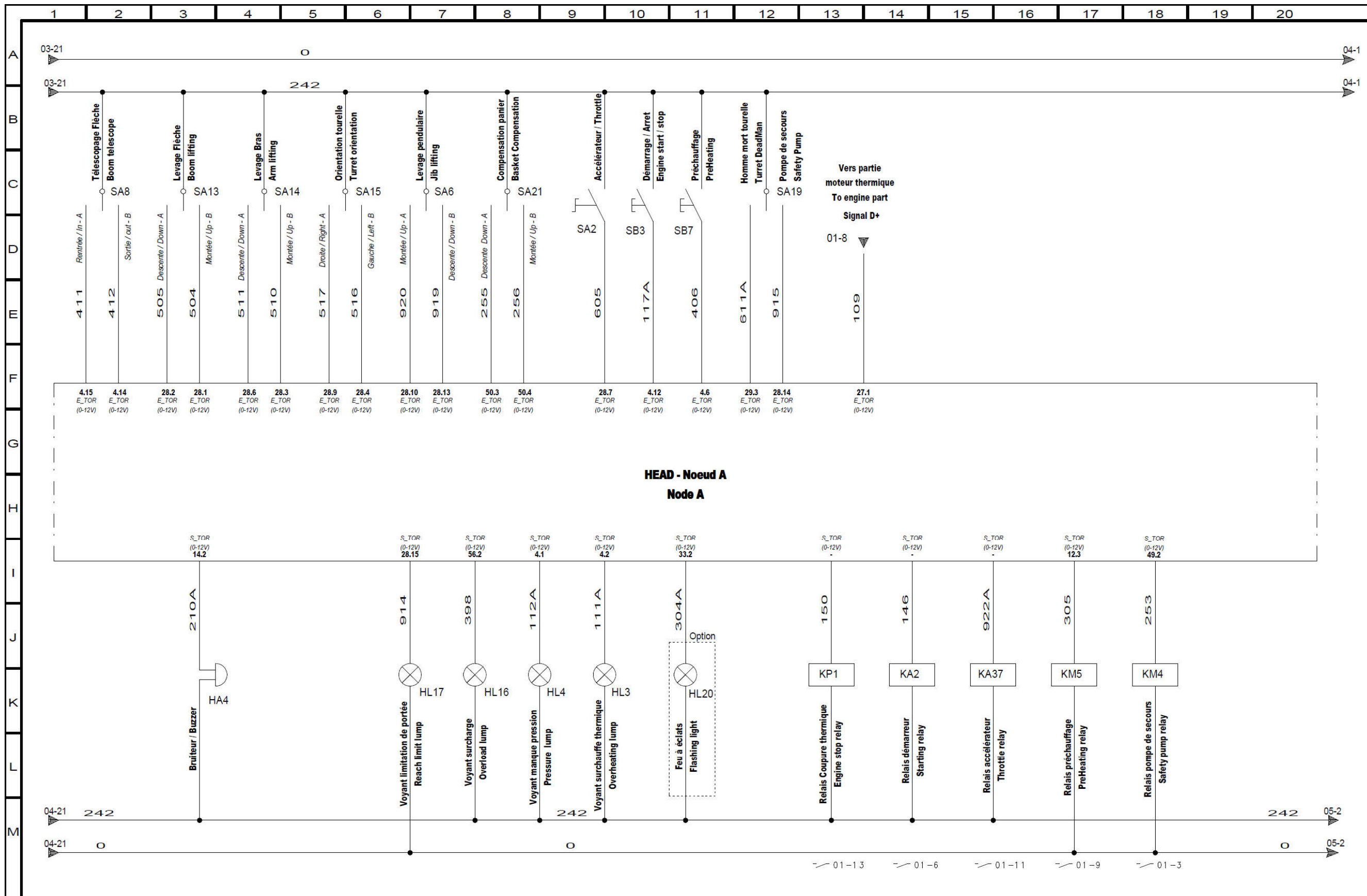

**HEAD - Noeud A**  
**Node A**

<p>La Péronnière BP 9 42152 L'HORME TEL: 04 77 29 24 24</p>	DESSINE PAR I. Troncy	DATE DE CREATION 18/02/2010	HA32_41PX-NT Partie Tourelle - Turret Part 159P319780	MODIF	IND	DATE	MODIFICATION	VISA	NBRE TOTAL DE FOLIOS 08  159P319780 <b>04</b>
	VERIFIE PAR L. Di Florio	DATE DE VERIFICATION 18/02/2010		F					

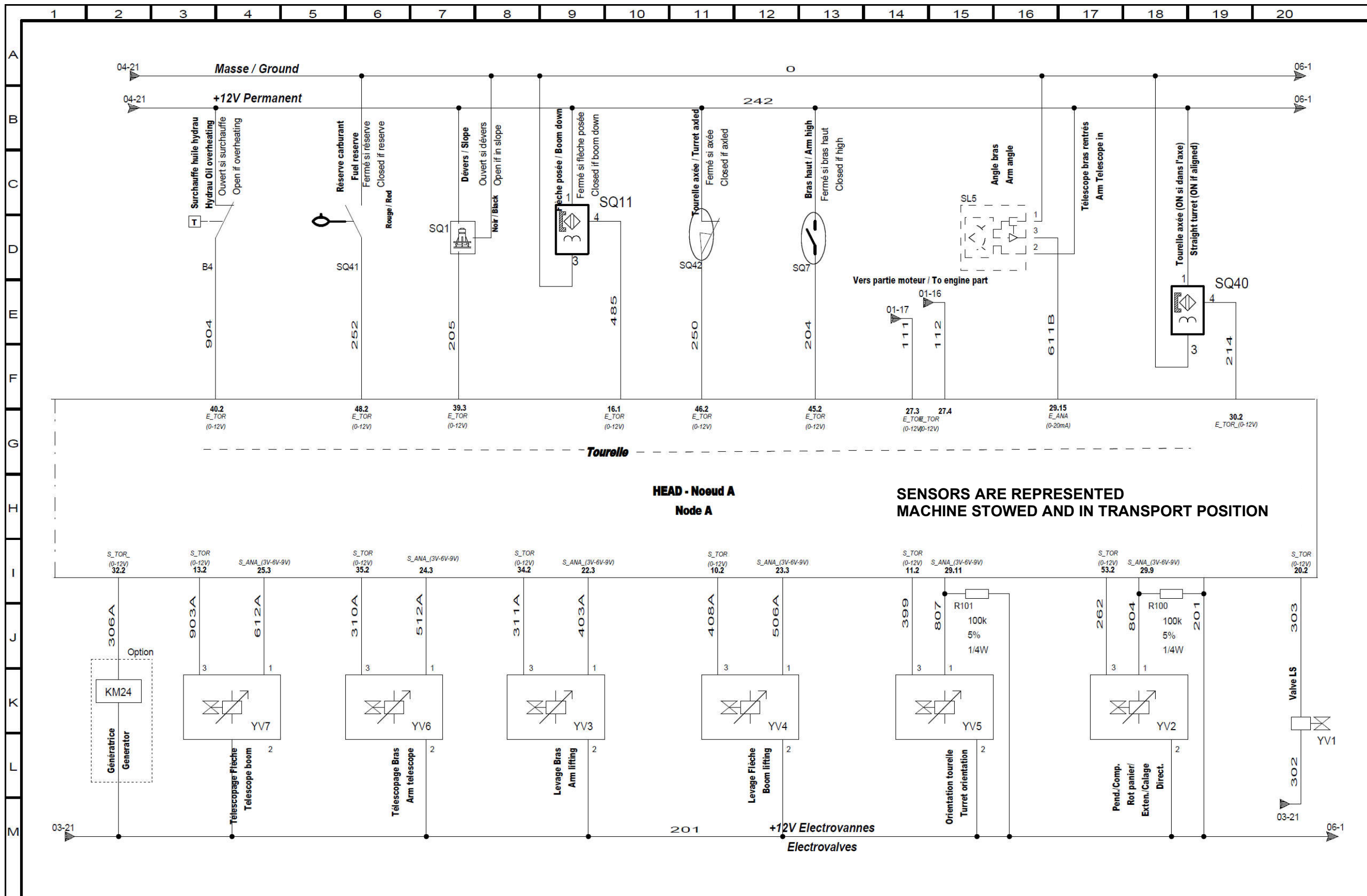

**HEAD - Noeud A**  
**Node A**

**SENSORS ARE REPRESENTED**  
**MACHINE STOWED AND IN TRANSPORT POSITION**

<p>La Péronnière BP 9 42152 L'HORME TEL: 04 77 29 24 24</p>	DESSINE PAR I. Troncy	DATE DE CREATION 18/02/2010	HA32_41PX-NT Partie Tourelle - Turret Part 159P319780	MODIF	IND	DATE	MODIFICATION	VISA	NBRE TOTAL DE FOLIOS 08
	VERIFIE PAR L. Di Florio	DATE DE VERIFICATION 18/02/2010							



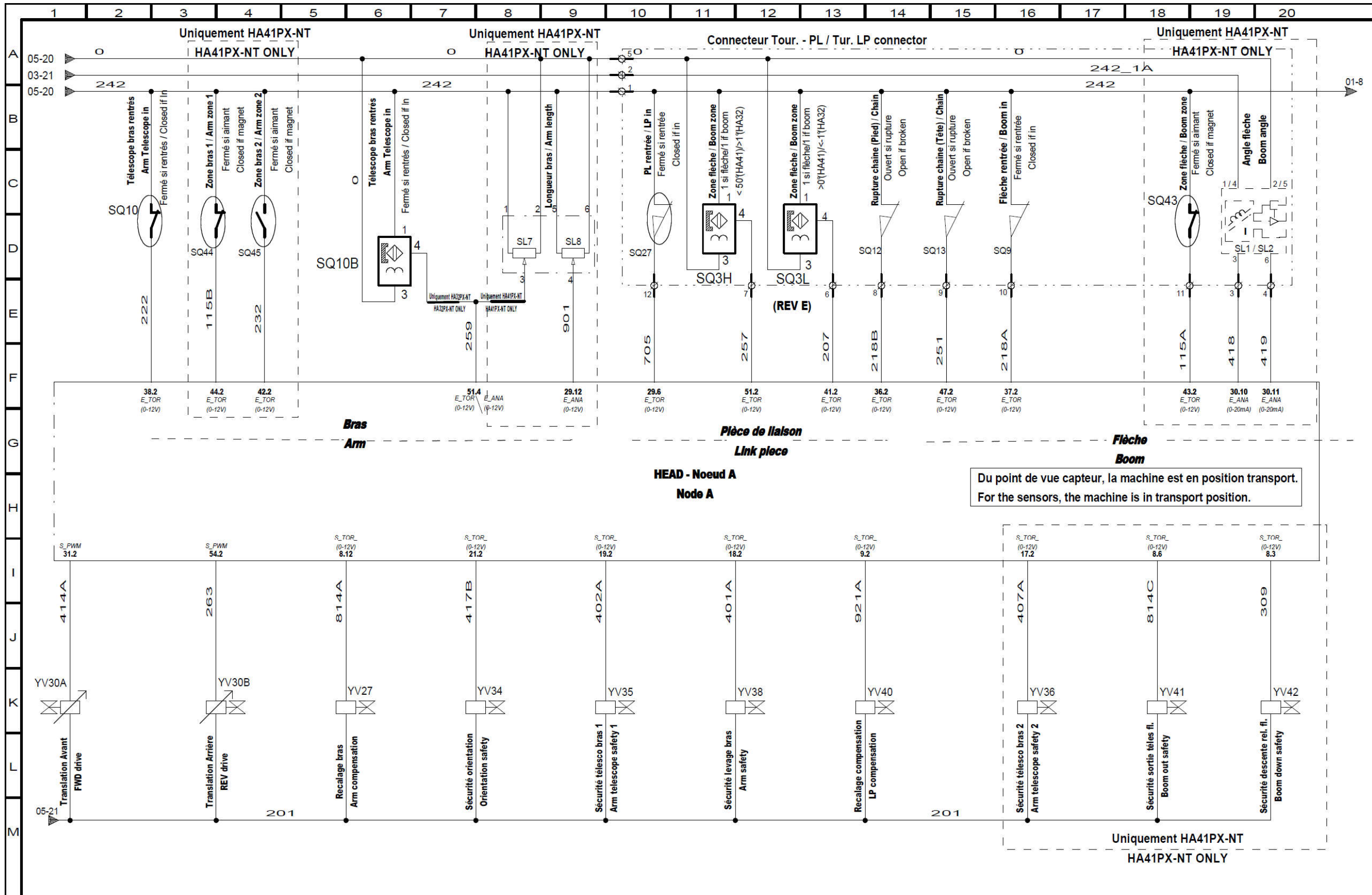

**Haulotte**  
GROUP  
La Péronnière  
BP 9 42152 L'HORME TEL: 04 77 29 24 24

DESSINE PAR I. Troncy	DATE DE CREATION 18/02/2010
VERIFIE PAR L. Di Florio	DATE DE VERIFICATION 18/02/2010

HA32_41PX-NT Partie Panier - Basket Part 159P319780	
F	

MODIF	IND	DATE	MODIFICATION	VISA

NBRE TOTAL DE FOLIOS 08	159P319780	06
----------------------------	------------	----



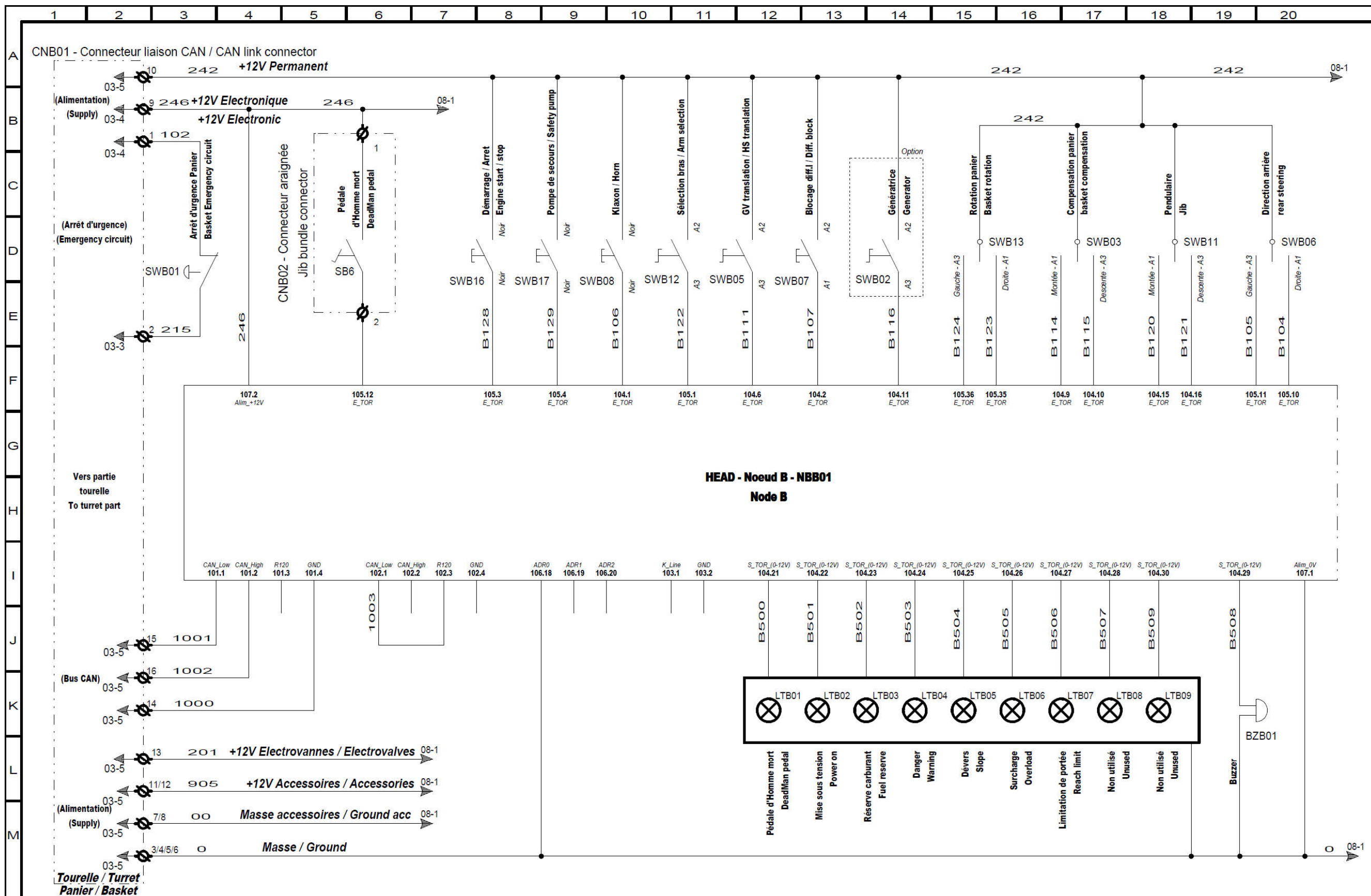

<p>La Péronnière BP 9 42152 L'HORME TEL: 04 77 29 24 24</p>	DESSINE PAR I. Troncy	DATE DE CREATION 18/02/2010	HA32_41PX-NT Partie Panier - Basket Part 159P319780	MODIF	IND	DATE	MODIFICATION	VISA	NBRE TOTAL DE FOLIOS 08
	VERIFIE PAR L. Di Florio	DATE DE VERIFICATION 18/02/2010		F					

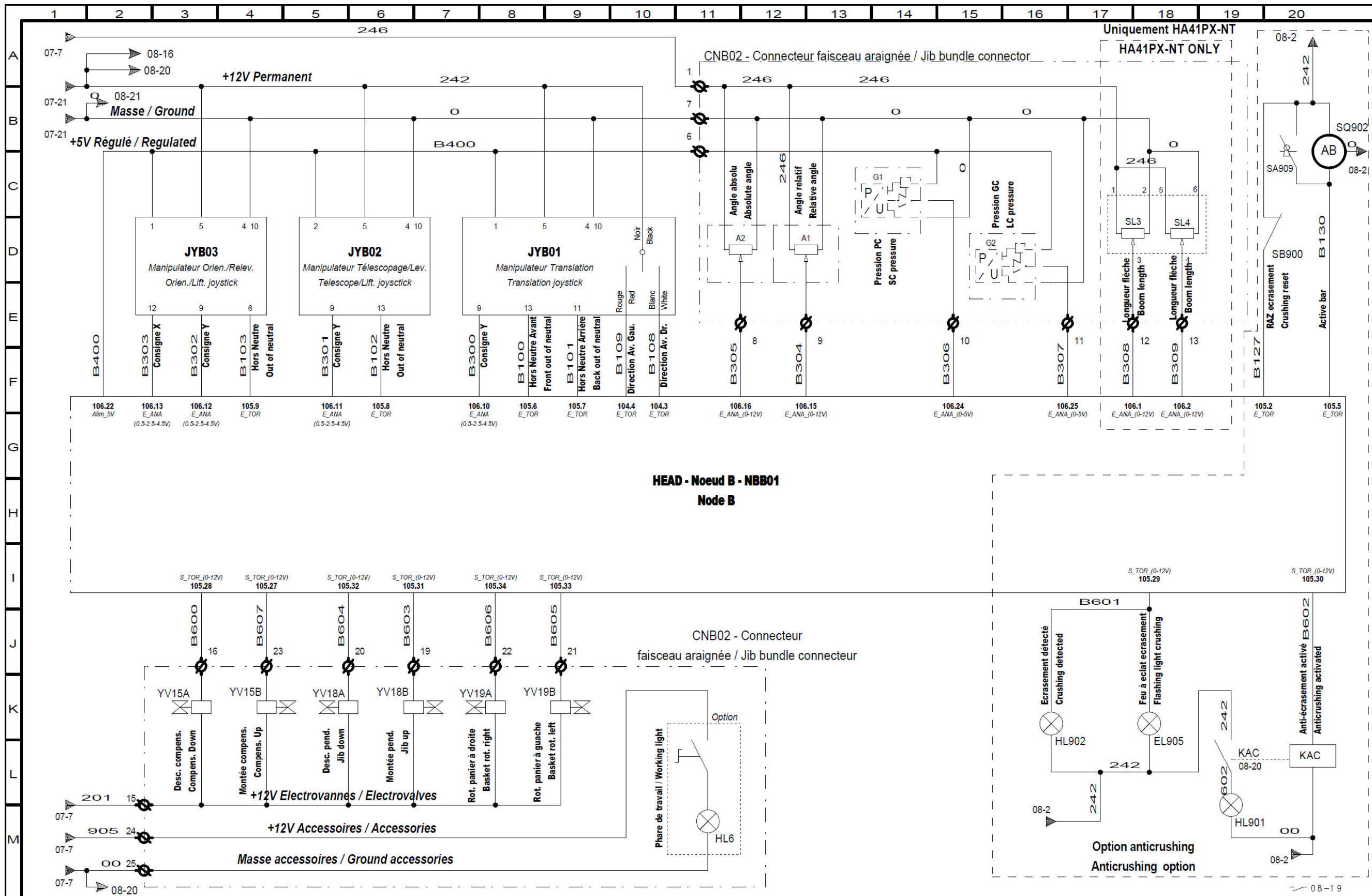

<p><b>Haulotte</b> GROUP</p> <p>La Péronnière BP 9 42152 L'HORME TEL: 04 77 29 24 24</p>	<p>DESSINE PAR I. Troncy</p>	<p>DATE DE CREATION 24/02/2010</p>	<p>HA32_41PX-NT Partie Panier - Basket Part 159P319780</p>	<p>MODIF</p>	<p>IND</p>	<p>DATE</p>	<p>MODIFICATION</p>	<p>VISA</p>	<p>NBRE TOTAL DE FOLIOS 08</p>
	<p>VERIFIE PAR L. Di Florio</p>	<p>DATE DE VERIFICATION</p>	<p>F</p>						<p>159P319780</p>



REV.	DATE	DESCRIPTION
A	26-05-2009	CHALLENGE
B	11-09-2009	CHALLENGE
C		CHALLENGE
D		CHALLENGE
E		CHALLENGE
F		CHALLENGE
G		CHALLENGE
H		CHALLENGE
I		CHALLENGE
J		CHALLENGE
K		CHALLENGE
L		CHALLENGE
M		CHALLENGE
N		CHALLENGE
O		CHALLENGE
P		CHALLENGE
Q		CHALLENGE
R		CHALLENGE
S		CHALLENGE
T		CHALLENGE

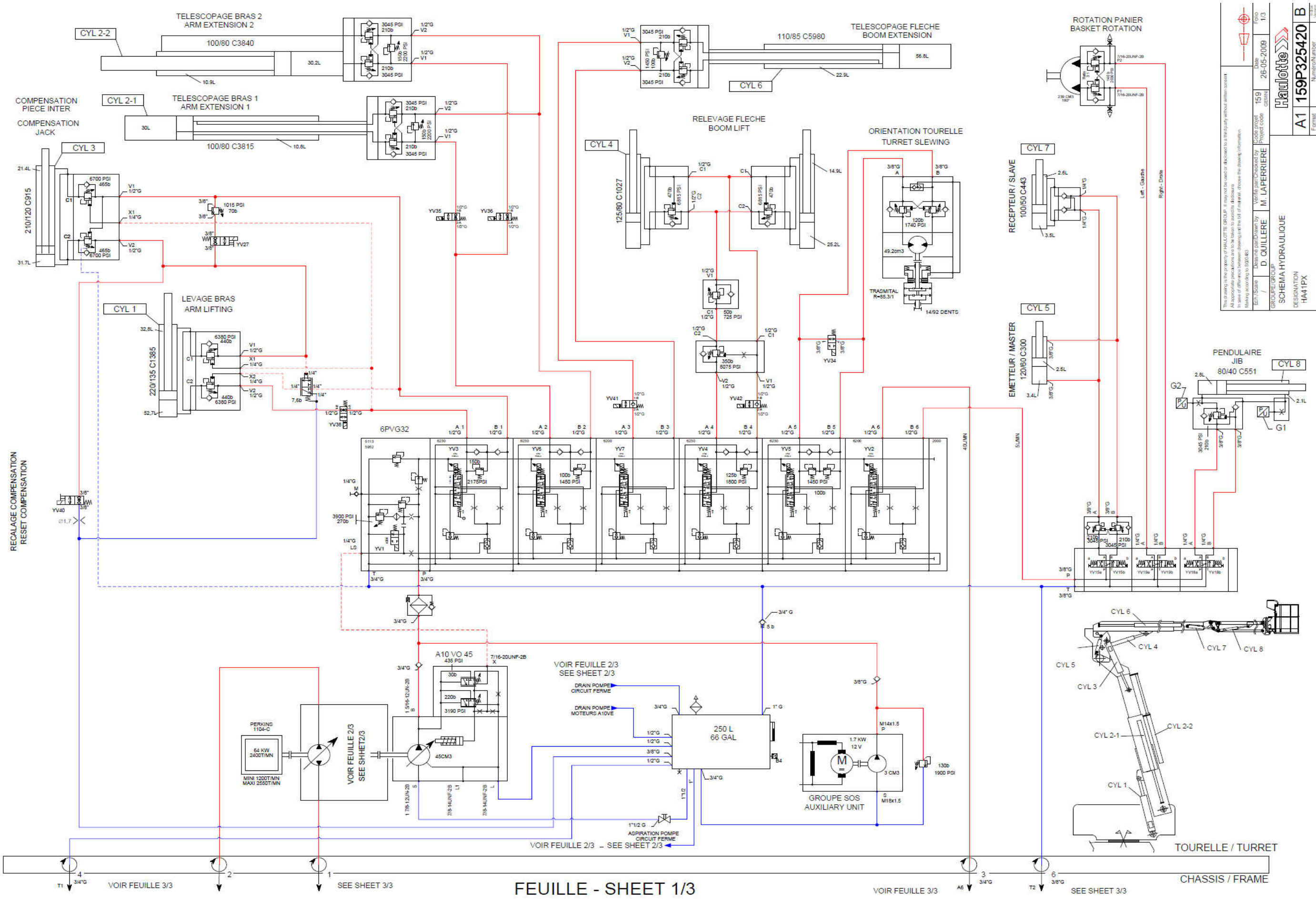

FEUILLE - SHEET 1/3

This drawing is the property of HAULOTTE GROUP. It may not be used or disclosed to a third party without written consent.  
 All appropriate precautions are to be taken to avoid accidents.  
 In case of differences between drawings and the list of material, choose the drawing information.  
 Marking according to ISO 9001.

Date: 26-05-2009  
 Project code: 159  
 Project name: CHALLENGE  
 Drawn by: M. LAPERRIERE  
 Checked by: D. QUILLERE  
 Design group: SCHEMA HYDRAULIQUE  
 Designation: HA41PX  
 Number: A1 159P325420 B

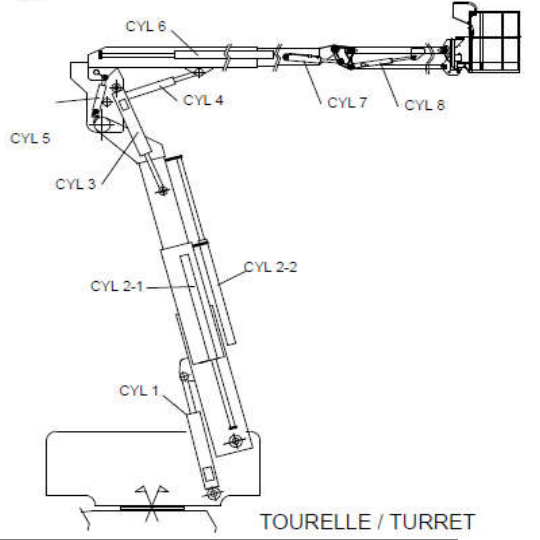

REV	DATE	DESCRIPTION	APPROVED BY
A	26-05-2009	CHANGEMENT DE LA PERIPHERIE	D. QUILLERE
B	11-08-2009	CHANGEMENT DE LA PERIPHERIE	D. QUILLERE

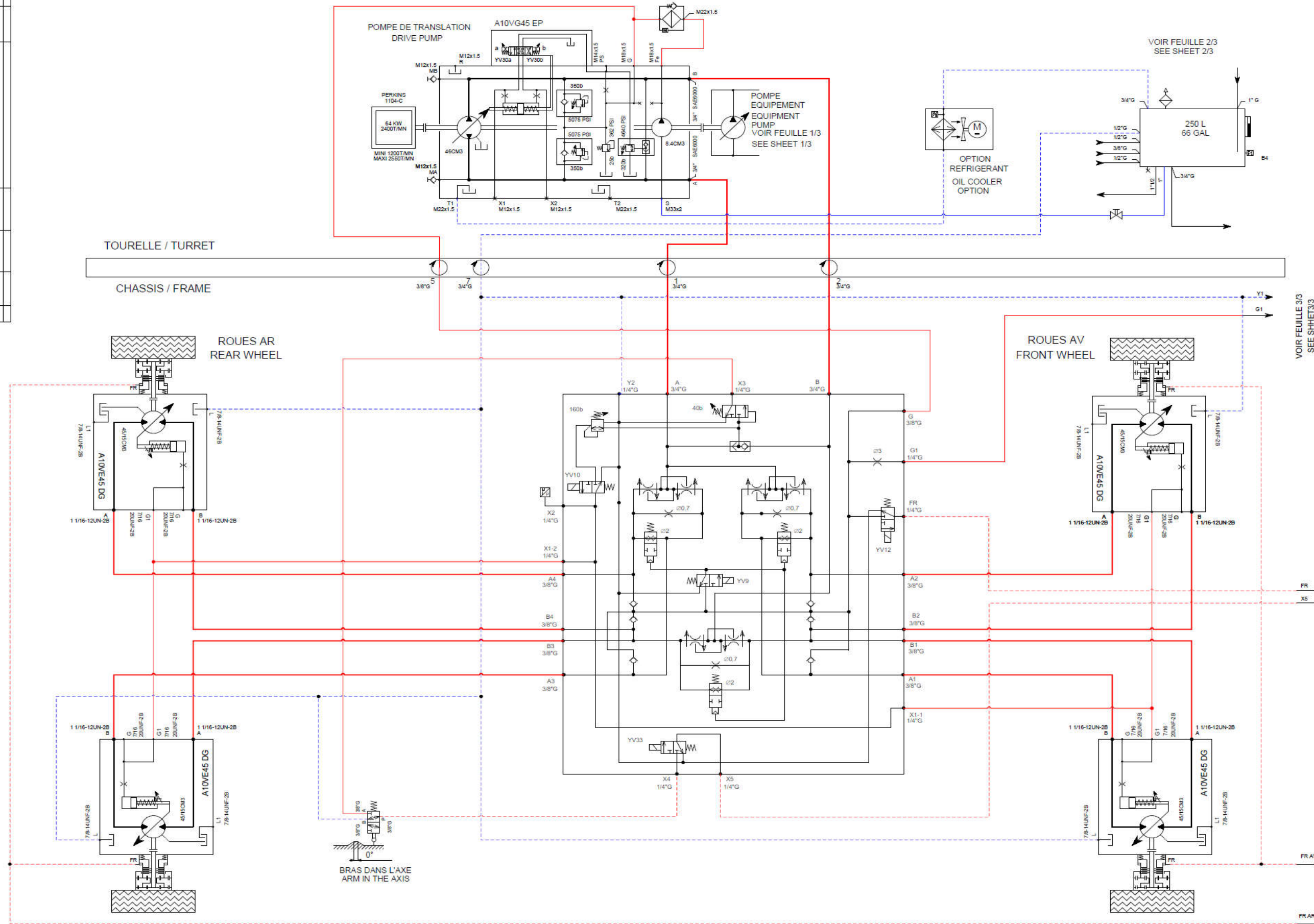

FEUILLE - SHEET 2/3

The drawing is the property of HAULOTTE GROUP. It may not be used or disclosed to a third party without written consent.  
 All appropriate precautions are to be taken to avoid fire or explosion.  
 In case of difference between drawing and the set of material, choose the drawing information.  
 Marking according to ISO 9043.

DESIGNED BY	D. QUILLERE
DESIGNED PART DRAWN BY	M. LAPERRIERE
GROUP/PROJECT CODE	159
DATE	26-05-2009
PROJECT CODE	04014
FOUR	2/3

SCHEMA HYDRAULIQUE  
 HA3241PX - H43TPX



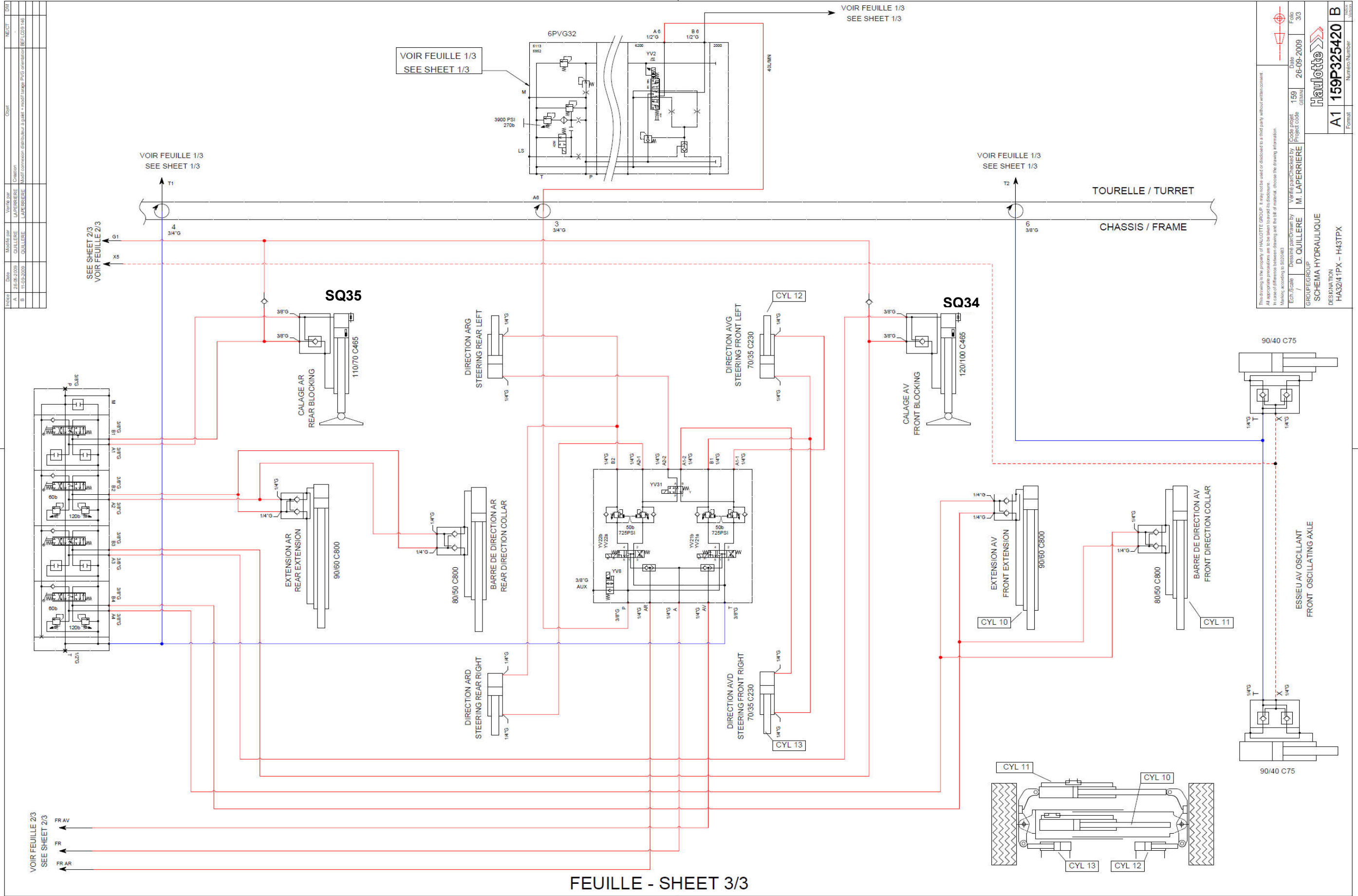

REV	DATE	DESCRIPTION
A	26-09-2009	CHANGEMENT DE LA POMPES HYDRAULIQUES
B	11-02-2009	CHANGEMENT DE LA POMPES HYDRAULIQUES

This drawing is the property of HAULOTTE GROUP. It may not be used or disclosed to a third party without written consent. All appropriate precautions are to be taken to avoid its disclosure.	
ESD: 50238 GROUPE HAULOTTE D. OULLIERE	Vérifié par/Checked by: M. LAPERRIERE Code projet/Project code: 159 Date/Date: 26-09-2009 Rev/Rev: 3/3
<b>HAULOTTE</b> SCHEMA HYDRAULIQUE HA3241PX - HA41PX	
A1 159P325420 Format/Format:	B N° de la feuille/Sheet Number:

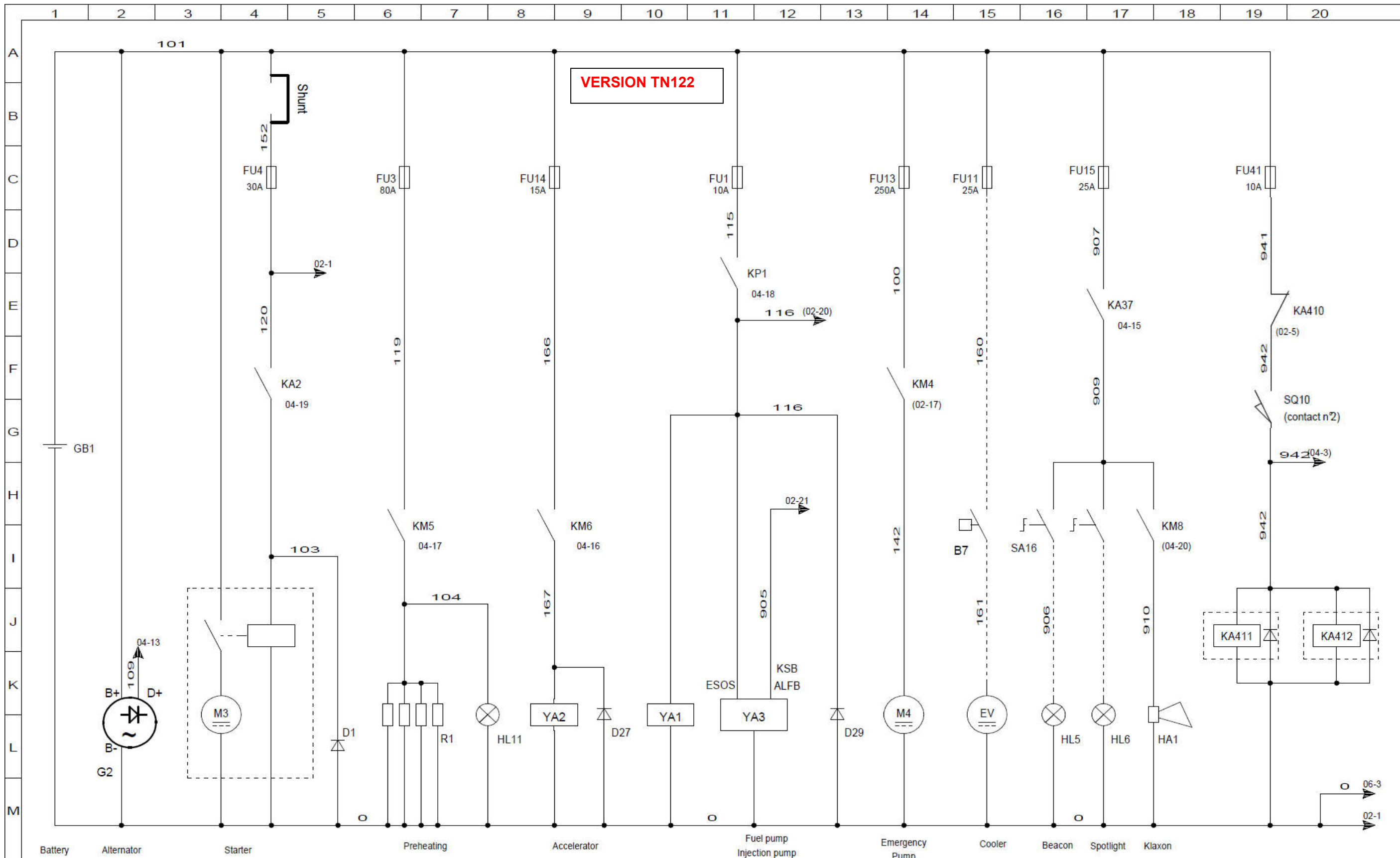

<b>Haulotte</b> <b>GROUP</b> La Péronnière BP 9 42152 L'HORME TEL: 04 77 29 24 24	DESSINE PAR B.Pallot	DATE DE CREATION 07/04/2005	Partie puissance HA41PX -TN122 (159P329870)	MODIF <b>C</b>	IND <b>07/11/2012</b>	DATE (6) DM9394 (num+gnd)	VISA <b>CL</b>	NBRE TOTAL DE FOLIOS 06  <b>SCHEMAS</b>	<b>01</b>
	VERIFIE PAR F.Lemire	DATE DE VERIFICATION 11/04/2005		HBA <b>B</b>	HBA <b>a</b>	05/10/2011 (2) Suppression DKMG1 et 2	JFT		
				HBA <b>a</b>	01/07/2009 creation	B.Pallot			

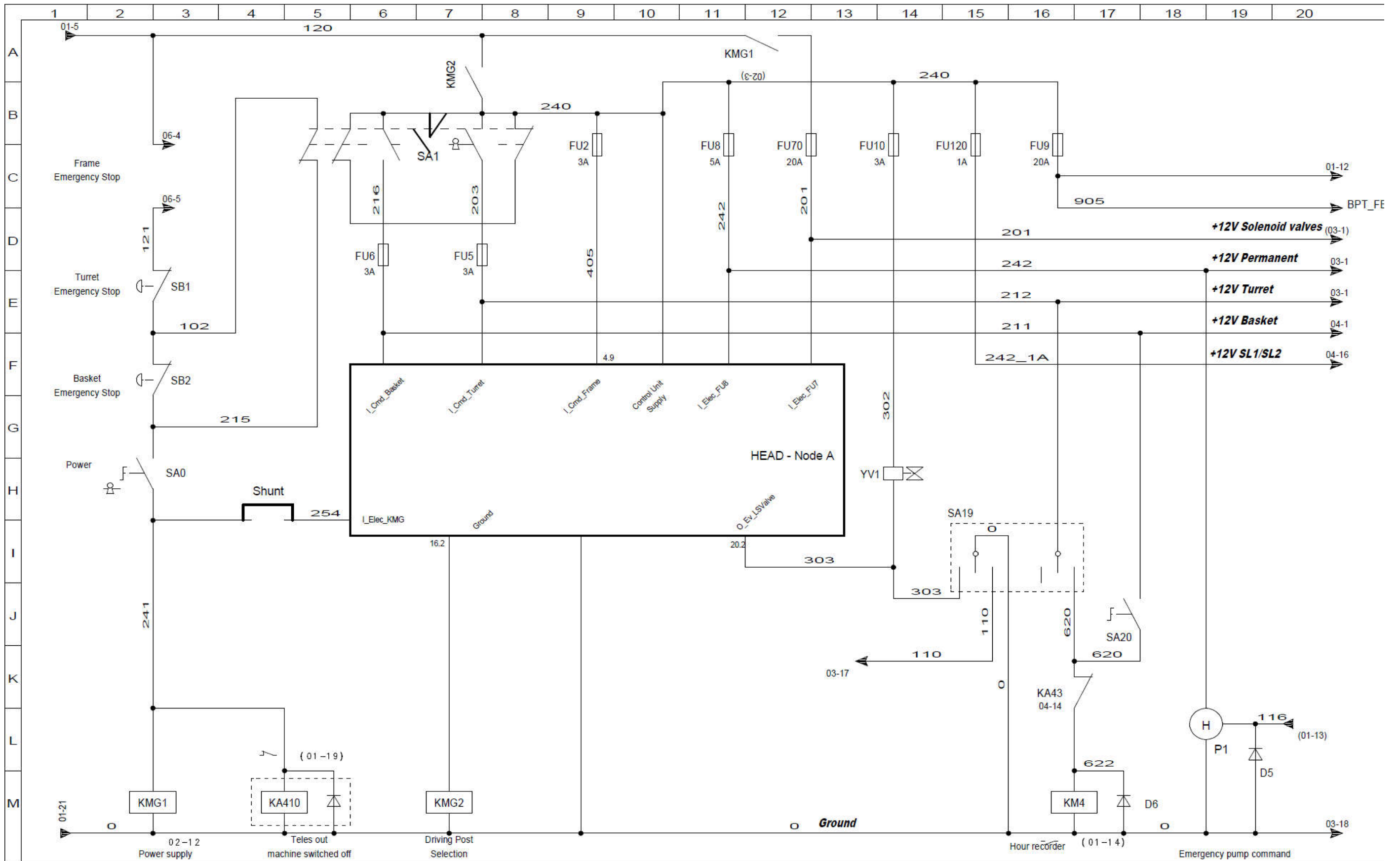

<b>Haulotte</b> GROUP La Péronnière BP 9 42152 L'HORME TEL: 04 77 29 24 24	DESSINE PAR B.Pallot	DATE DE CREATION 07/04/2005	Sélection de poste, fusible ligne d'alimentation HA41PX - TN122 (159P329870)	MODIF IND DATE MODIFICATION VISA	NBR TOTAL DE FOLIOS 06  SCHEMAS <b>02</b>
	VERIFIE PAR F.Lemire	DATE DE VERIFICATION 11/04/2005		VISA	



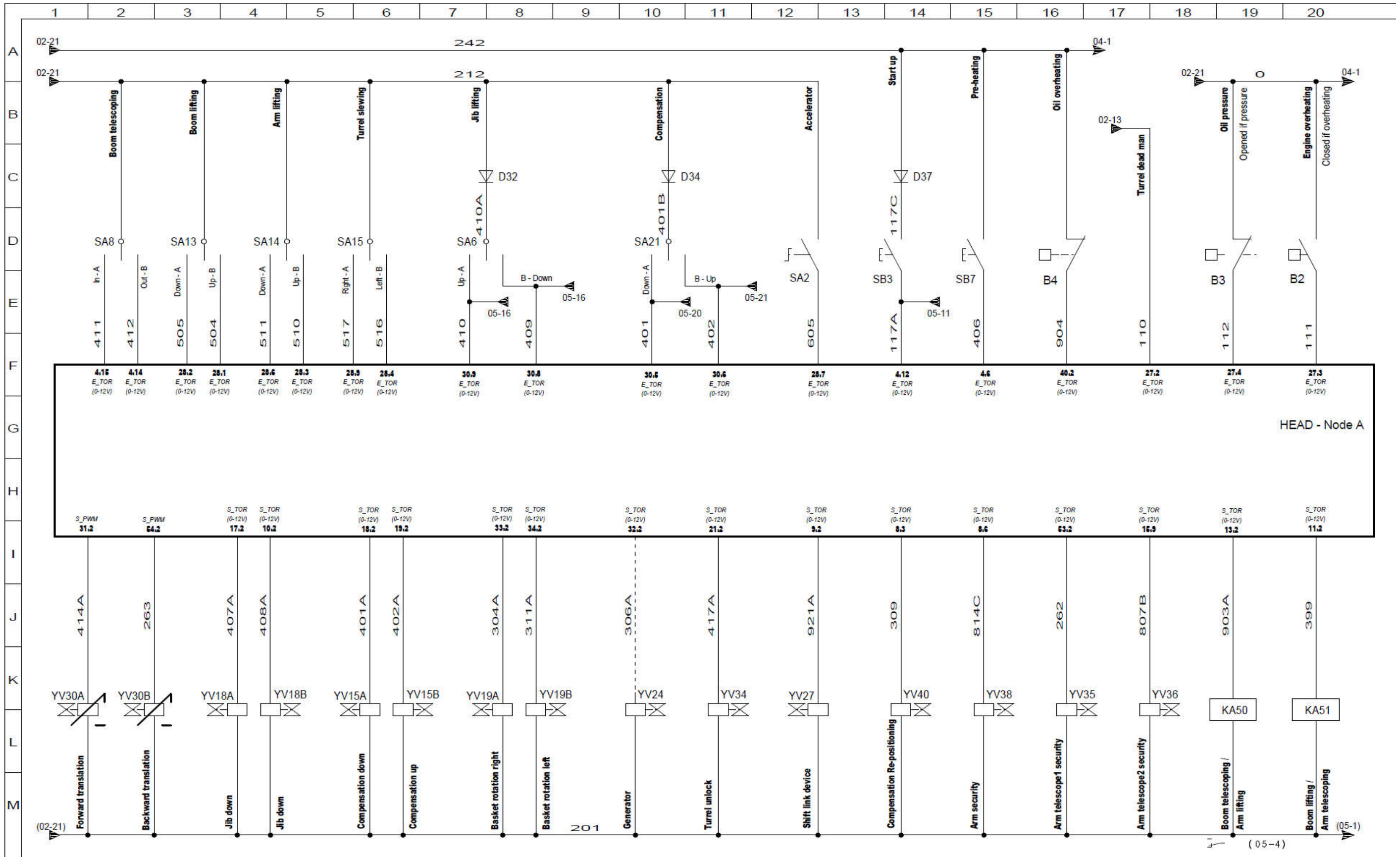

<p>La Péronnière BP 9 42152 L'HORME TEL: 04 77 29 24 24</p>	DESSINE PAR B.Pallot	DATE DE CREATION 07/04/2005	Poste tourelle, électrovannes HA41PX - TN122 (159P329870)	MODIF	IND	DATE	MODIFICATION	VISA	NBRE TOTAL DE FOLIOS 06
	VERIFIE PAR F.Lemire	DATE DE VERIFICATION 11/04/2005		SCHEMAS	03				



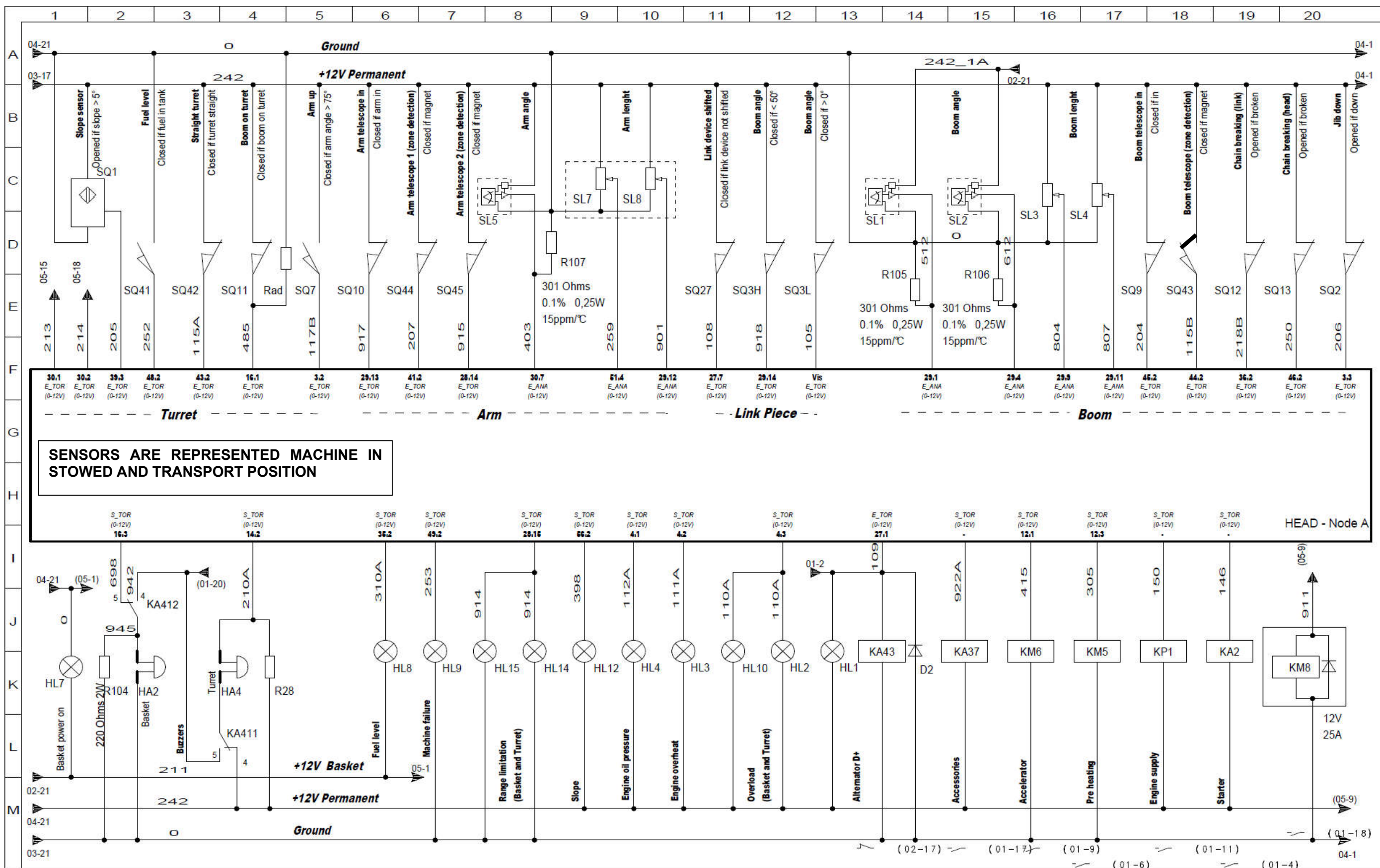

<p>La Péronnière BP 9 42152 L'HORME TEL: 04 77 29 24 24</p>	DESSINE PAR B.Pallot	DATE DE CREATION 07/04/2005	Détecteurs, voyants, relais, bruiteurs HA41PX - TN122 (159P329870)	MODIF	IND	DATE	MODIFICATION	VISA	NBR TOTAL DE FOLIOS 06  SCHEMAS
	VERIFIE PAR F.Lemire	DATE DE VERIFICATION 11/04/2005		(01-6)	(01-4)	04			

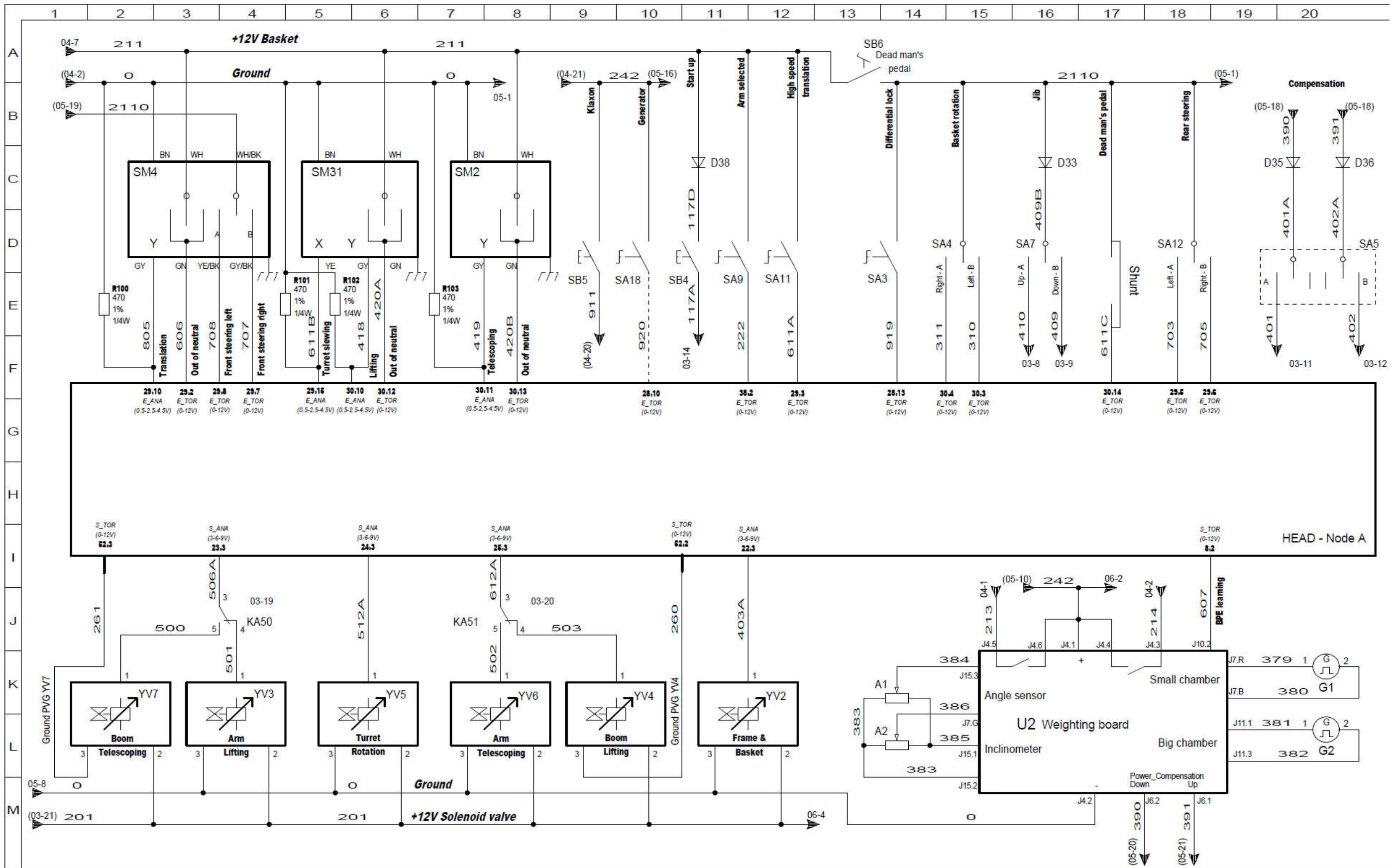

<b>Haulotte</b> GROUP La Péronnière BP 9 42152 L'HORME TEL: 04 77 29 24 24	DESSINE PAR B.Pallot	DATE DE CREATION 07/04/2005	Partie panier, PVG HA41PX - TN122 (159P329870)	MODIF	IND	DATE	MODIFICATION	VISA	NBR TOTAL DE FOLIOS 06  SCHEMAS <b>05</b>
	VERIFE PAR F.Lemire	DATE DE VERIFICATION 11/04/2005		MODIF	IND	DATE	MODIFICATION	VISA	



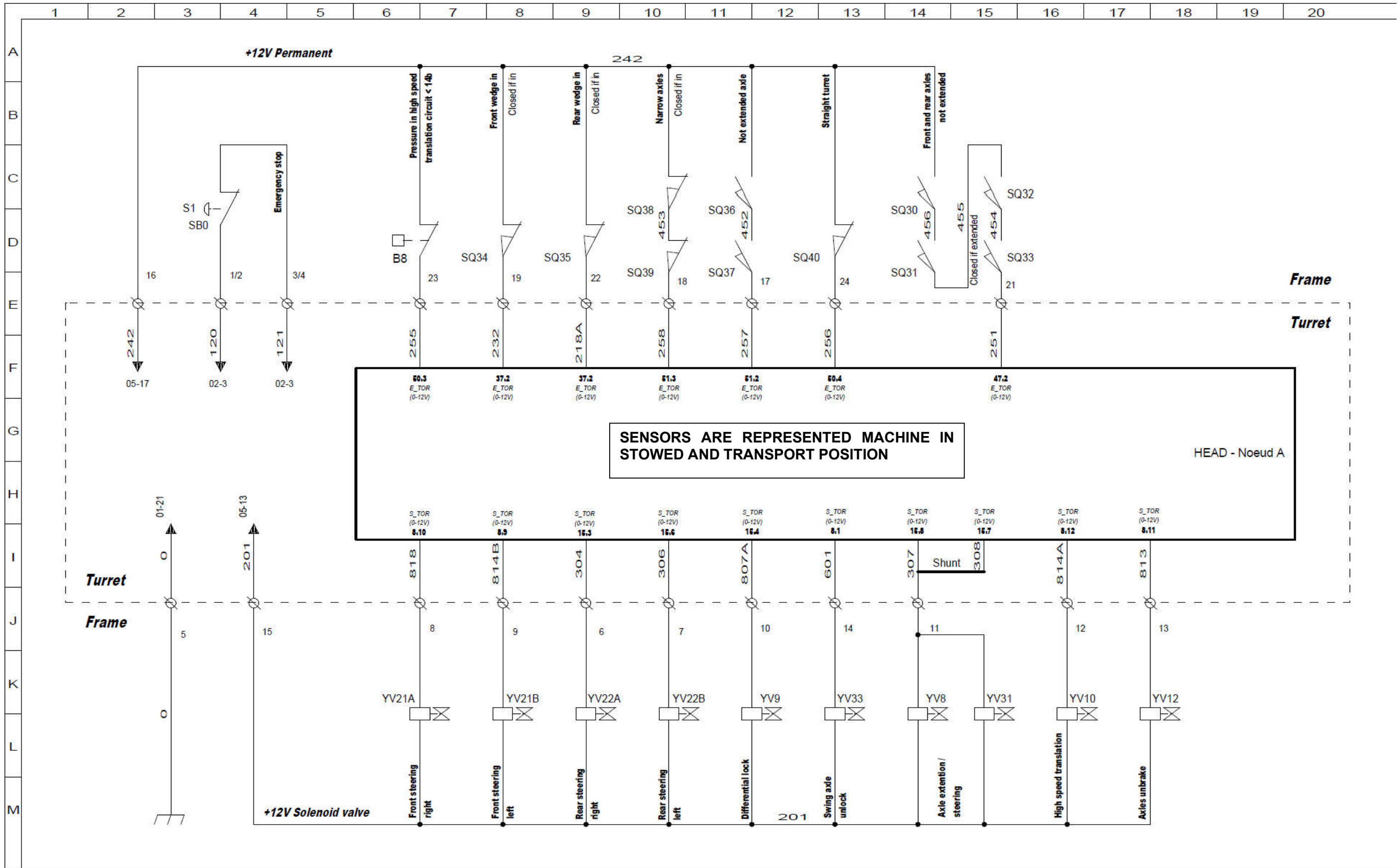

<b>Haulotte</b> GROUP La Péronnière BP 9 42152 L'HORME TEL: 04 77 29 24 24	DESSINE PAR <b>HBA</b>	DATE DE CREATION 04/11/2009	Partie châssis HA41PX - TN122 (159P329870)	MODIF 	IND 	DATE 	MODIFICATION 	VISA 	NBRE TOTAL DE FOLIOS 06  <b>SCHEMAS</b>	<b>06</b>
	VERIFIE PAR <b>BPT</b>	DATE DE VERIFICATION 19/11/2009								

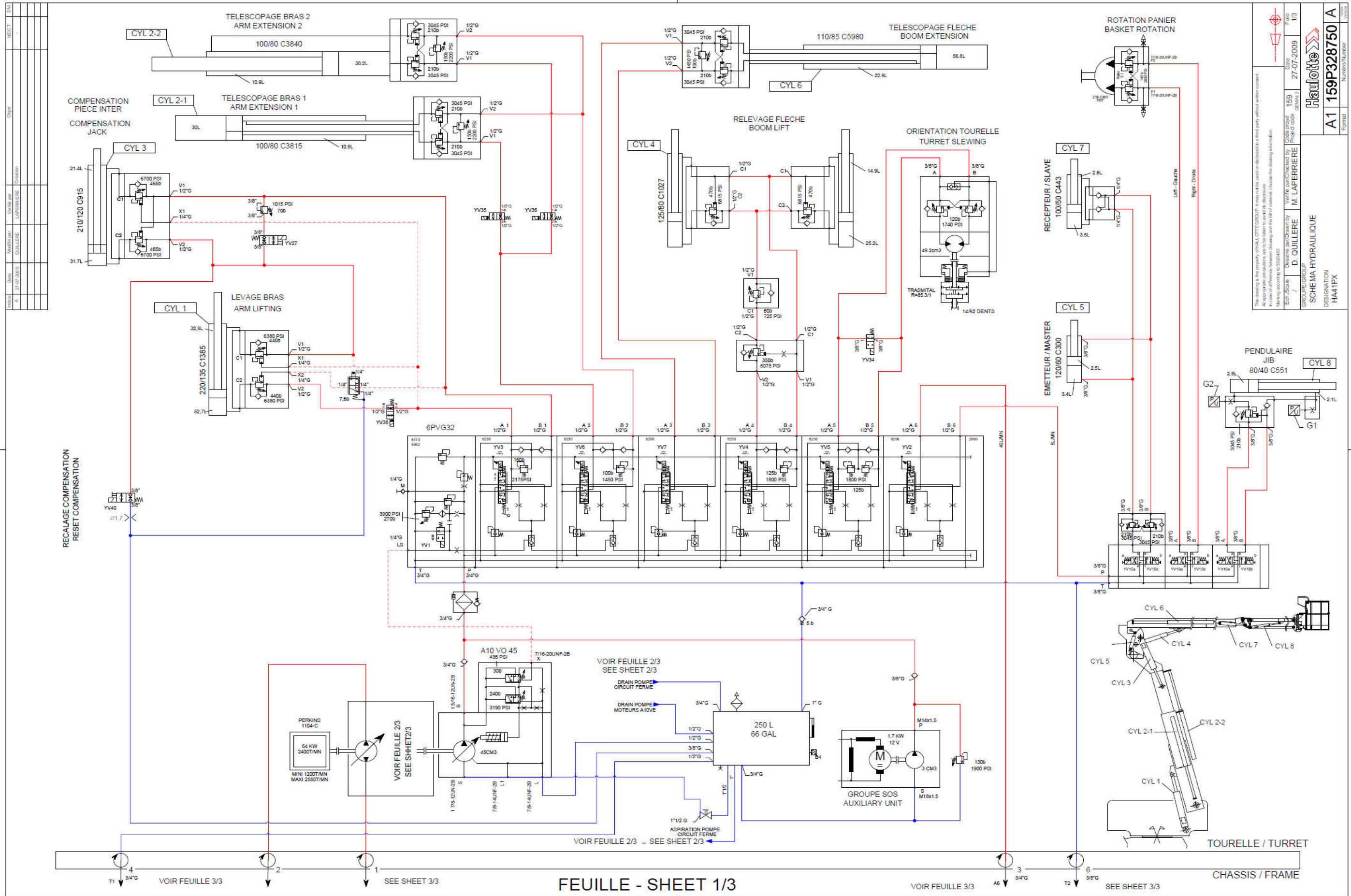

DATE	27-07-2009	PROJET	159
DESIGNER	D. OUILLE	VERIFIE PAR	M. LAPERRIERE
ECRITURE	1/1	DATE	27-07-2009
GROUP	SCHEMA HYDRAULIQUE	FORMAT	A1
DESIGNATION	HA41PX	Numero	159P328750
		Version	A

FEUILLE - SHEET 1/3



INSTR.	DATE	MANIF. PAR	VERIF. PAR	CHIFFR.	RELECT
A	27.07.2009	DUILLERE	LAPERRIERE		

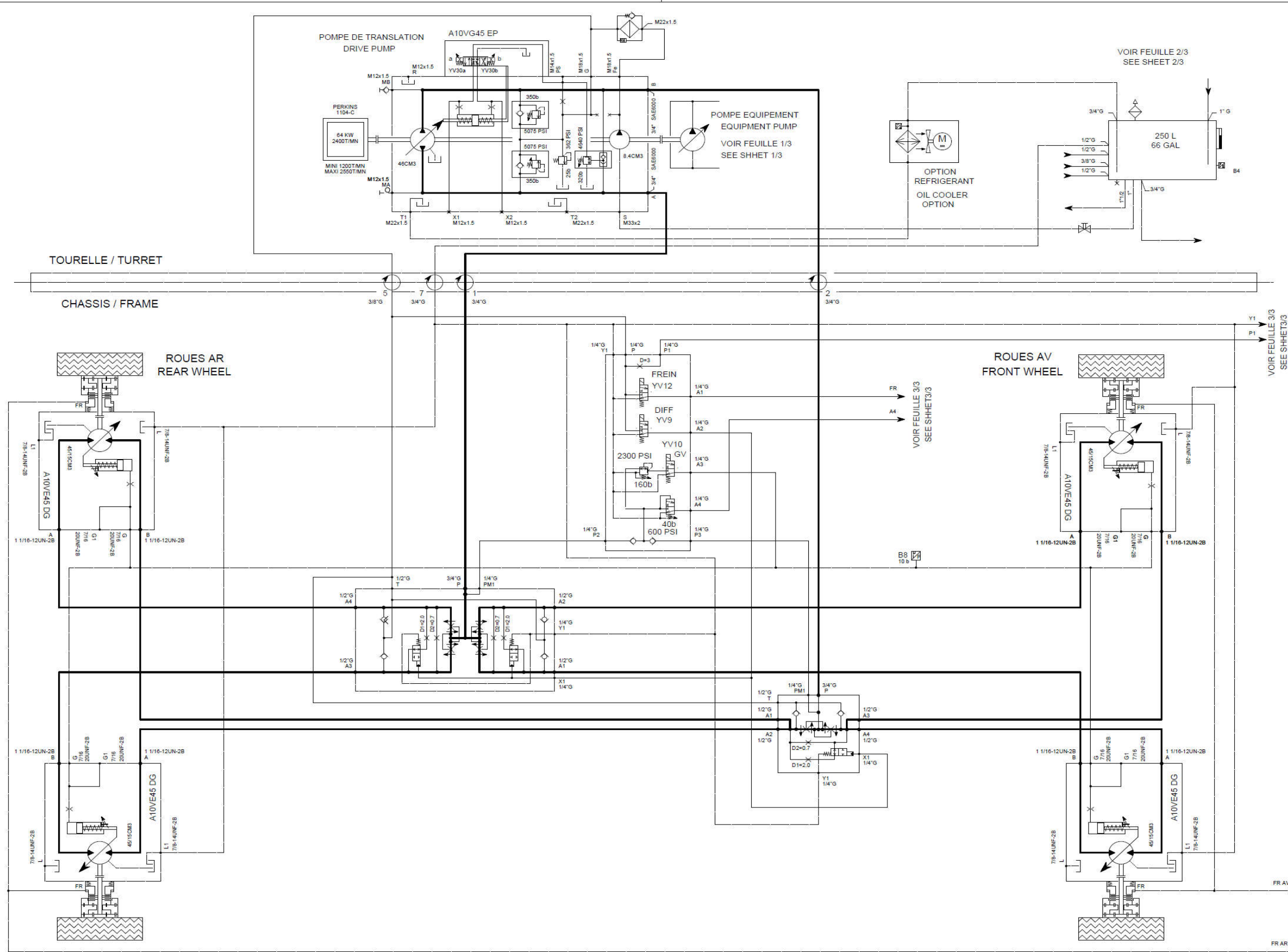

FEUILLE - SHEET 2/3

This drawing is the property of HAULOTTE GROUP. It may not be used or disclosed to a third party without written consent. All appropriate precautions are to be taken to avoid its disclosure. Reproduction, copying, or any other use without the prior written consent of Haulotte is strictly prohibited.

EDR / ESCRIT	DESIGNER	VERIF. / CHECKED BY	DATE	PROJ. CODE	FEUILLE
D. OUILLERE	M. LAPERRIERE		27-07-2009	159	2/3

GROUP / GROUPE: HAULOTTE  
 DESIGNATION: SCHEMA HYDRAULIQUE  
 HA3241PX

Form: A1  
 Number: 159P328750  
 A

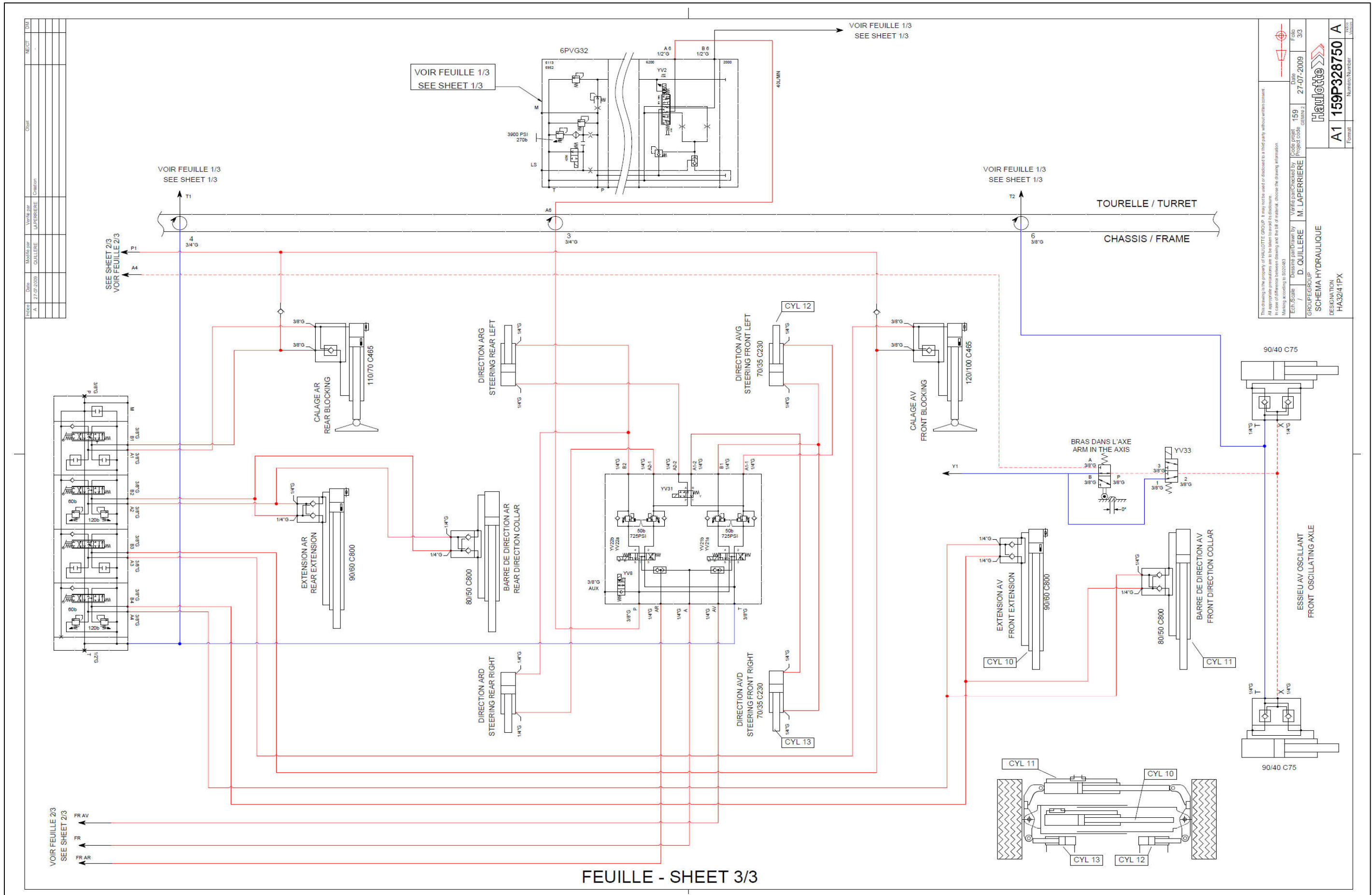

<p>This drawing is the property of HAULOTTE GROUP. It may not be used or disclosed to a third party without written consent. All appropriate precautions are to be taken to avoid its disclosure. In case of difference between drawing and the list of material, choose the drawing information. Mating according to ISO8441</p>	
<p>Drawn by: D. QUILLERE</p>	<p>Checked by: M. LAPERRIERE</p>
<p>Project code: 159</p>	<p>Date: 27-07-2009</p>
<p>Scale: GEMANZ</p>	<p>File: 3/3</p>
<p>GROUP: HAULOTTE</p>	
<p>DESCRIPTION: SCHEMA HYDRAULIQUE</p>	
<p>HA324TPX</p>	
<p>Format: A1</p>	<p>Number/Version: 159P328750 A</p>

**LOCATION OF COMPONENTS ON MAIN PRINTED CIRCUIT**

