



RWF40... Compact Universal Controller

optimized for temperature and pressure control through the control of modulating or multi-stage burners

User Manual

The RWF40... controller and this User Manual are intended for use by OEMs which integrate the controller into their products!

Contents

1.	Introduction	6
1.1	General notes	6
1.2	Description	6
1.3	Typographical conventions.....	7
1.3.1	Warning symbols	7
1.3.2	Notification symbols	7
1.3.3	Presentation.....	7
2.	Type of unit.....	8
2.1	Type field	8
3.	Installation	9
3.1	Installation site and climatic conditions	9
3.2	Dimensions.....	9
3.3	Side-by-side mounting.....	10
3.4	Mounting in a panel cutout.....	10
3.5	Cleaning the front panel	11
3.6	Removing the controller module	11
4.	Electrical connections	12
4.1	Installation notes.....	12
4.2	Block diagram	13
4.3	Assignment of terminals	14
4.4	Galvanic separation	17
5.	Operating modes.....	18
5.1	Low-fire operation.....	18
5.2	High-fire operation	18
5.2.1	Modulating burner, 3-position output.....	18
5.2.2	Modulating burner, modulating output.....	19
5.2.3	Two-stage burner, 3-position output	19
5.2.4	Two-stage burner, modulating output	20
5.3	Safety shutdown	20
5.4	Pre-defined setpoint	20
5.4.1	Setpoint changeover «SP1 / SP2», analog setpoint shift	21
5.4.2	Setpoint changeover «SP1» / external setpoint.....	22
5.4.3	Setpoint «SP1», analog / binary setpoint shift	23
5.4.4	External setpoint, binary setpoint shift	24
5.5	Weather-dependent setpoint shift	25
5.5.1	Heating curve slope	26
5.6	Response threshold «Q»	27
5.7	Cold start of the plant	28

6.	Operation	29
6.1	Basic display.....	30
6.1.1	Meaning of the display and buttons.....	30
6.2	User level.....	31
6.2.1	Changing the setpoints.....	31
6.2.2	Manual operation of a modulating burner.....	33
6.2.3	Manual operation of a two-stage burner.....	33
6.2.4	Start self-setting	34
6.2.5	Display of the software version and unit of actual value	34
6.3	Parameter level	35
6.3.1	Enter parameters.....	35
6.4	Configuration level	35
6.4.1	Changing the configuration code.....	35
7.	Parameter settings	36
8.	Configuration.....	38
8.1	C111 inputs.....	38
8.2	C112 limit comparator, controller type, setpoint «SP1», locking	40
8.3	C113 unit address, dimensional unit, out-of-range.....	44
8.3.1	SCL scaling of standard signal range start, analog input 1	45
8.3.2	SCH scaling of standard signal range end, analog input 1	45
8.3.3	SCL2 scaling of standard signal range start, analog input 2.....	45
8.3.4	SCH2 scaling of standard signal range end, analog input 2.....	46
8.3.5	SPL lower setpoint limit.....	46
8.3.6	SPH upper setpoint limit	46
8.3.7	OFF1 actual value correction for analog input 1	46
8.3.8	OFF2 actual value correction for analog input 2	46
8.3.9	OFF3 actual value correction for analog input 3	46
8.3.10	dF1 2 nd order digital filter for analog input 1	46
9.	Self-setting function.....	47
9.1	Self-setting function in high-fire operation	47
9.2	Checking the controller parameters	49
10.	What to do if.....	50
10.1	...numbers are flashing on the display	50

11.	Technical data	51
11.1	Inputs	51
11.1.1	Analog input 1 (actual value)	51
11.1.2	Analog input 2 (external setpoint, setpoint shift)	51
11.1.3	Analog input 3 (outside temperature)	52
11.1.4	Binary input «D1»	52
11.1.5	Binary input «D2»	52
11.2	Outputs	52
11.2.1	Output 1 (release of burner)	52
11.2.2	Output 2, 3 (3-position output)	52
11.2.3	Output 4 (limit comparator)	52
11.2.4	Output 5, modulating output (option)	53
11.2.5	Transducer supply	53
11.2.6	Interface RS-485 (optional)	53
11.3	General ratings	53
11.3.1	Measured value accuracy	54
11.3.2	Measured value circuit monitoring	54
11.3.3	Environmental conditions	54
12.	Current settings	55
12.1	Process data	55
12.2	Parameter level	55
12.3	Configuration level	56

1.1 General notes



Please read this User Manual before starting up the controller. Keep the Manual in a place that is accessible to all users at all times. Please help us improve the Manual. Your suggestions will be welcome.



All necessary settings and, where required, settings inside the unit are described in this User Manual, for controller software version 126.01.01.

⇒ Section 6.2.5 «Display software version and dimensional unit»

Should any difficulties arise during commissioning, you are asked not to carry out any unauthorized manipulations on the unit. You could endanger your rights under the unit warranty! Please contact us in such a case.



When returning modules, assemblies or components to Landis & Staefa, the regulations of DIN EN 100 015 «Protection of electrostatically sensitive devices» must be observed. Use only the appropriate **ESD** packaging for transport.

Please note that we cannot accept any liability for damage caused by ESD.

ESD = electrostatic discharge

1.2 Description

Use The RWF40... is used primarily for controlling temperature or pressure in oil- or gas-fired heating plants. It is a compact 3-position controller without position feedback that acts on the burner. An external switch can be used to change it over to a 2-position controller for the control of two-stage burners. The built-in thermostat function switches the burner on and off. An adjustable response threshold is used to switch to a higher burner output (high-fire operation).

Control A shift controller controls the temperature or pressure. Minimum and maximum limits for the setpoint can be set. A self-setting function is available as a standard feature.

The plug-in controller module measures 96 x 48 x 127.5 mm and is especially suited for mounting in control panels. The controller incorporates two 4-digit 7-segment displays for the actual value (red) and setpoint (green). A limit comparator is also provided and its switching behavior can be set on the configuration level.

A selection can be made between eight different limit comparator functions.

Options An RS-485 interface is used for integration into a data network. Output 5 can be used as a modulating output for modulating or 2-stage operation. All connections are made via screw terminals at the rear of the unit.

1.3 Typographical conventions

1.3.1 Warning symbols

The signs for **Danger** and **Caution** are used in this Manual under the following conditions:



Danger

This symbol is used where there may be a **danger to personnel** if the instructions are disregarded or not strictly followed!



Caution

This symbol is used where there may be **damage to equipment or data** if the instructions are disregarded or not strictly followed!



Caution

This symbol is used if **pre-cautions must be taken** in handling electrostatically sensitive components.

1.3.2 Notification symbols



Note

This symbol is used to draw your **special attention** to a remark.



Reference

This symbol refers to **additional information** in other Manuals, chapters or sections.

abc¹

Footnote

Footnotes are **comments, referring to specific parts of the text**. They consist of two parts:

- 1) The **markings** in the text are arranged as continuous superscript numbers
- 2) The **footnote text** is placed at the bottom of the page and starts with a number and a period



Action

This symbol indicates that a **required action** is described.

The individual steps are indicated by an asterisk, e.g.:

* Press the ▲ button

1.3.3 Presentation

PGM

Buttons

Buttons are shown in a box. Either symbols or text are possible. If a button has multiple assignments, the text shown is always the one that corresponds to the function currently used.

EXIT + ▲

Button combinations

The representation of buttons combined with a plus sign means that first the  button must be pressed and held down and then the other button.

2.1 Type field

Location The type field is glued onto the housing. The type designation consists of operating voltage and type reference of the unit.

Types

Type of unit	Description
RWF40.000A97 RWF40.010A97 ¹ .	Basic version with 3-position output
RWF40.001A97 RWF40.011A97 ¹ .	With additional modulating output
RWF40.002A97 RWF40.012A97 ¹ .	With additional modulating output and RS-485 interface

¹. Packing variants



The supply voltage connected must match the voltage given on the type field.

Factory setting

The measured value range and the analog inputs are set at the factory.

⇒ Chapter 8 «Configuration»

Accessories

Adapter frame ARG40 for plants where the pre-decessor model RWF32... was used, which shall be converted to the RWF40... .

Bracket ARG41 for mounting the RWF40... on 35 mm DIN rails conforming to DIN 46277.

Dummy cover AVA10.200/109 for covering a control panel cutout for the RWF40...

3.1 Installation site and climatic conditions

- The installation site should be as free as possible from vibrations, dust and corrosive media
- The controller should be installed as far away as possible from sources of electromagnetic fields, such as frequency converters or high-voltage ignition transformers

Relative humidity: $\leq 95\%$ (non-condensing)

Ambient temperature range: $-20\dots+50\text{ }^{\circ}\text{C}$

Storage temperature range: $-40\dots+70\text{ }^{\circ}\text{C}$

3.2 Dimensions

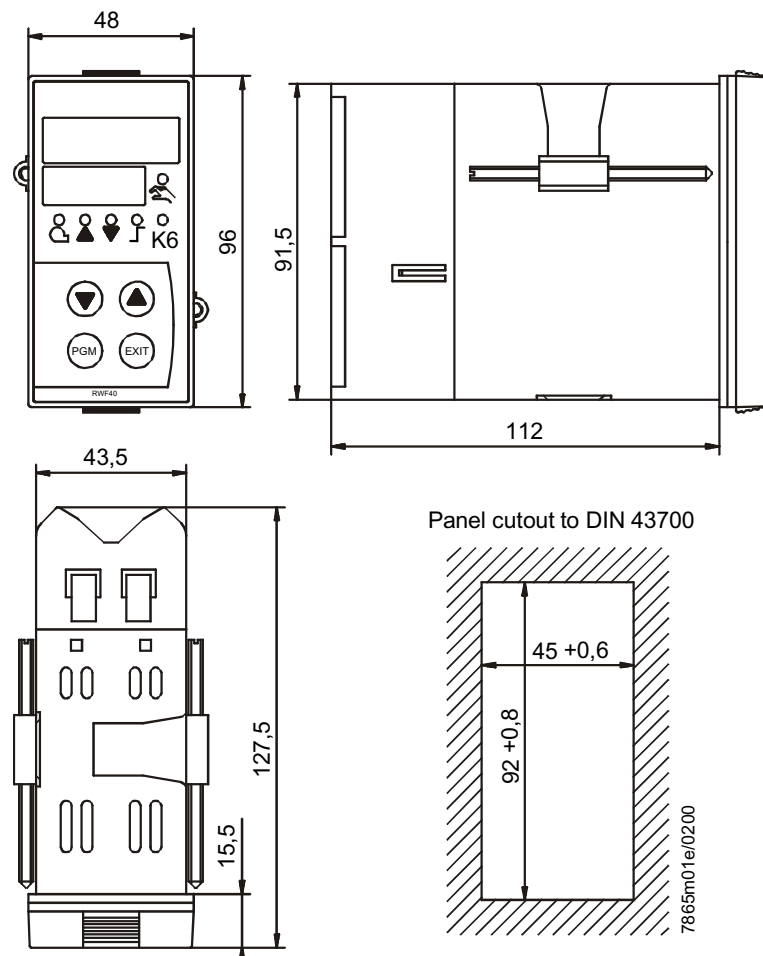

3.3 Side-by-side

If several controllers are mounted side-by-side or above one another in a control panel, the minimum spacing must be observed, namely 30.5 mm vertically and 10.5 mm horizontally.

3.4 Mounting in a panel cutout

- * Place the seal provided onto the controller housing.



The unit must be installed with the seal so that no water or oil can penetrate the housing!

- * Insert the controller from the front into the panel cutout.

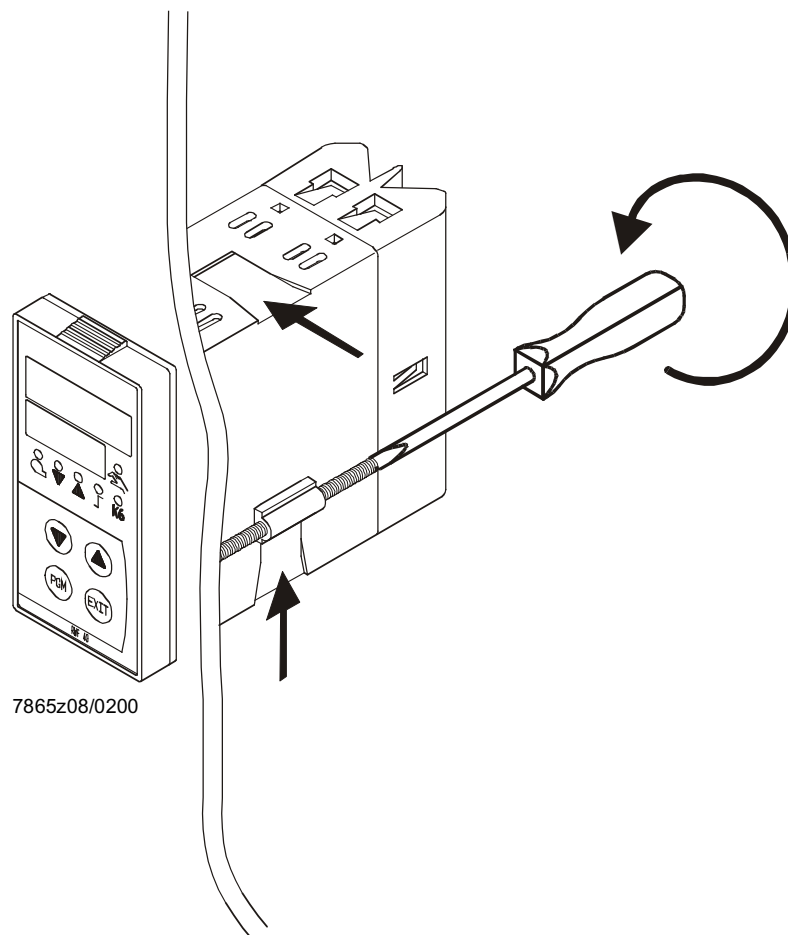

- * At the rear of the panel, push the fixing elements into the guide slots from the side or top. The flat faces of the fixing elements must lie against the housing.
- * Place the fixing elements against the rear of the panel, and tighten them evenly with a screwdriver.

3.5. Cleaning the front panel

The front panel can be cleaned with normal washing and rinsing agents or detergents.



It is **not** resistant to corrosive acids, caustic solutions and abrasive cleaners, or cleaning with high-pressure cleaners!

3.6 Removing the controller module

The controller module can be removed from the housing for servicing.



The rules of DIN EN 100 015 «Protection of electrostatically sensitive devices » must be adhered to for internal work on the controller! **No liability** will be accepted for damage caused by electrostatic discharge.

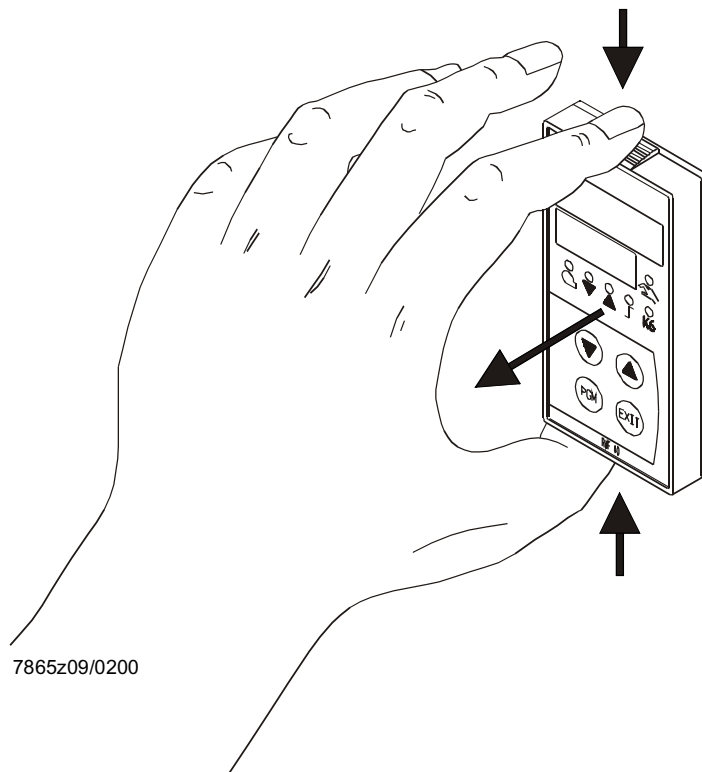

- * Press the ribbed surfaces together (at top and bottom) and pull out the controller module.

4.1 Installation notes

Safety regulations

- The choice of cable, the installation and the electrical connections of the controller must conform to the regulations of VDE 0100 «Regulations for the installation of power circuits with nominal voltages below AC 1000 V», or appropriate local regulations
- The electrical connections may only be carried out by qualified personnel
- If contact with live parts is possible while working on the unit, the controller must be disconnected from the power supply at both poles

Fusing



- An internal current-limiting resistor interrupts the supply voltage in the event of a short-circuit. The external fusing should not be rated above 1 A (slow). The output relays must be fused for a maximum of 2 A to prevent contact welding in the event of a short-circuit in the load circuit

⇒ Section 11.2 «Outputs»

- No other loads may be connected to the supply terminals of the controller

Interference suppression

- The electromagnetic compatibility and interference suppression levels conform to standards and regulations listed under «Technical data»

⇒ Chapter 11 «Technical data»

- Input, output and supply cables should be routed separately, not parallel to one another
- Arrange sensor and interface cables as twisted and screened cables, and do not run them close to power cables or components. Ground the screening to the controller **at one end** to the «TE» terminal
- Earth the «TE» terminal of the controller to the protective earth. This cable must have a cross-sectional area that is at least as large as that of the supply cables. Earthing cables must be wired in a star configuration to a common earthing point connected to the protective earth of the supply. Earthing cables may not be looped from one controller to another

Incorrect use

- The unit is not suitable for installation in areas with an explosion hazard
- Incorrect settings on the controller (setpoint, data of parameter and configuration levels) can affect the proper functioning of the following process or lead to damage. Safety devices that are independent of the controller, such as overpressure relief valves or temperature limiters / monitors should therefore always be provided, and only be capable of adjustment by qualified personnel. Please observe the appropriate safety regulations. Since self-setting cannot be expected to handle all possible control loops, the stability of the actual value that is produced should be checked
- The analog inputs of the controller may not exceed a maximum voltage of AC 30 V or DC 50 V against «TE»

⇒ Section 4.3 «Galvanic separation»

4.2 Block diagram

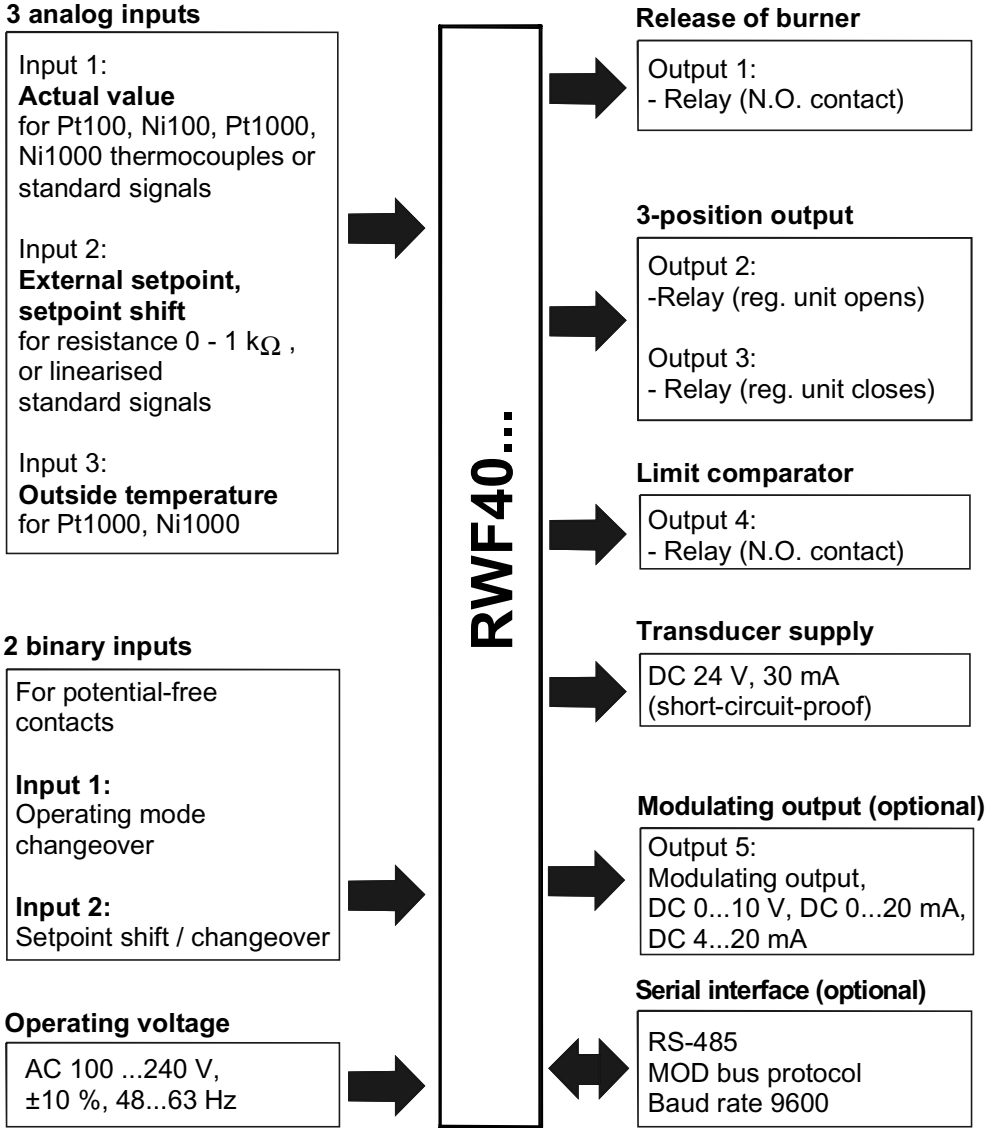

7865f01e/0200

4. Electrical connections

4.3 Assignment of terminals



Electrical connections may only be made by qualified personnel!

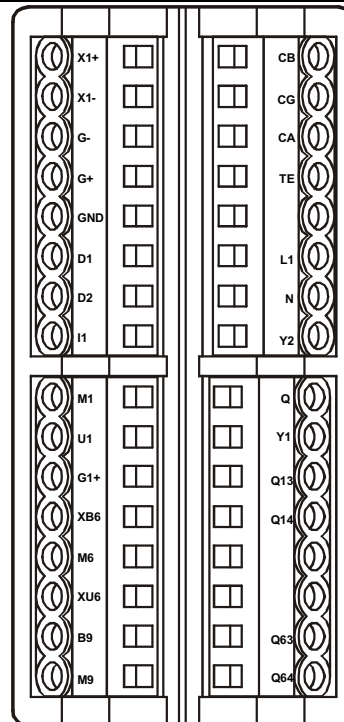

7865z07/1199

Outputs	Display LED	Terminal no.	Connection diagram
Relay 1: release of burner Contact protection: Varistor S07K275		Q14 pole Q13 N.O. contact	 7865a11/1199
Relay 2: regulating unit opens Contact protection: RC unit	▲	Y1 N.O. contact Q common pole	 7865a16/1099
Relay 3: regulating unit closes Contact protection: RC unit	▼	Y2 N.O. contact	
Relay 4: limit comparator Contact protection: Varistor S07K275	K6	Q64 pole Q63 N.O. contact	 7865a15/1099
Modulating output (optional) DC 0 (4)...20 mA, 0 (2)...10 V		X1+ X1-	 7865a17/1099

4. Electrical connections

Analogue input 1 (actual value)	Terminals	Connection diagram
Thermocouple	I1 M1	
Resistance thermometer in 3-wire circuit	M1 G1+ I1	
Resistance thermometer in 2-wire circuit, line compensation through offset correction (OFF1)	M1 G1+	
Current input DC 0...20 mA, 4...20 mA	I1 M1	
Voltage input DC 0...1 V, 0...10 V	U1 M1	

Analogue input 2 (setpoint and setpoint shift)	Terminals	Connection diagram
Resistance potentiometer Offset correction (OFF2)	XB6 start M6 slider M6 end	
Current input DC 0...20 mA, 4...20 mA	XB6 M6	
Voltage input DC 0...1 V, 0...10 V	XU6 M6	

Analogue input 3 (outside temperature)	Terminals	Connection diagram
Resistance thermometer in 2-wire circuit, line compensation through offset correction (OFF3)	B9 M9	

4. Electrical connections

Binary inputs	Terminals	Connection diagram
Operating mode selector ⇒ Section 5.2 «High-fire operation»	D1	<p>D1 ○ ————</p> <p>D2 ○ ————</p> <p>GND ○ ————</p> <p>7865a12/1099</p>
Setpoint shift / changeover ⇒ Sections 5.4.1...5.4.4	D2	
Common ground	GND	

Operating voltage, interface	Terminals	Connection diagram
Operating voltage AC 100...240 V ±10 %, 48...63 Hz	L1 line N neutral	<p>L1 ○ ————</p> <p>N ○ ————</p> <p>TE ○ ————</p> <p>7865a18/1099</p>
Technical earth	TE	

Operating voltage for transducer	G+ G-	<p>G+ ○ ———— +</p> <p>DC 24 V / 30 mA</p> <p>G- ○ ———— -</p> <p>7865a14/1099</p>
Serial interface RS-485	CA CB CG	<p>RxD / TxD+</p> <p>RxD / TxD-</p> <p>GND</p>

4.4 Galvanic separation

The diagram shows the maximum potential differences that may exist between the function modules in the controller.

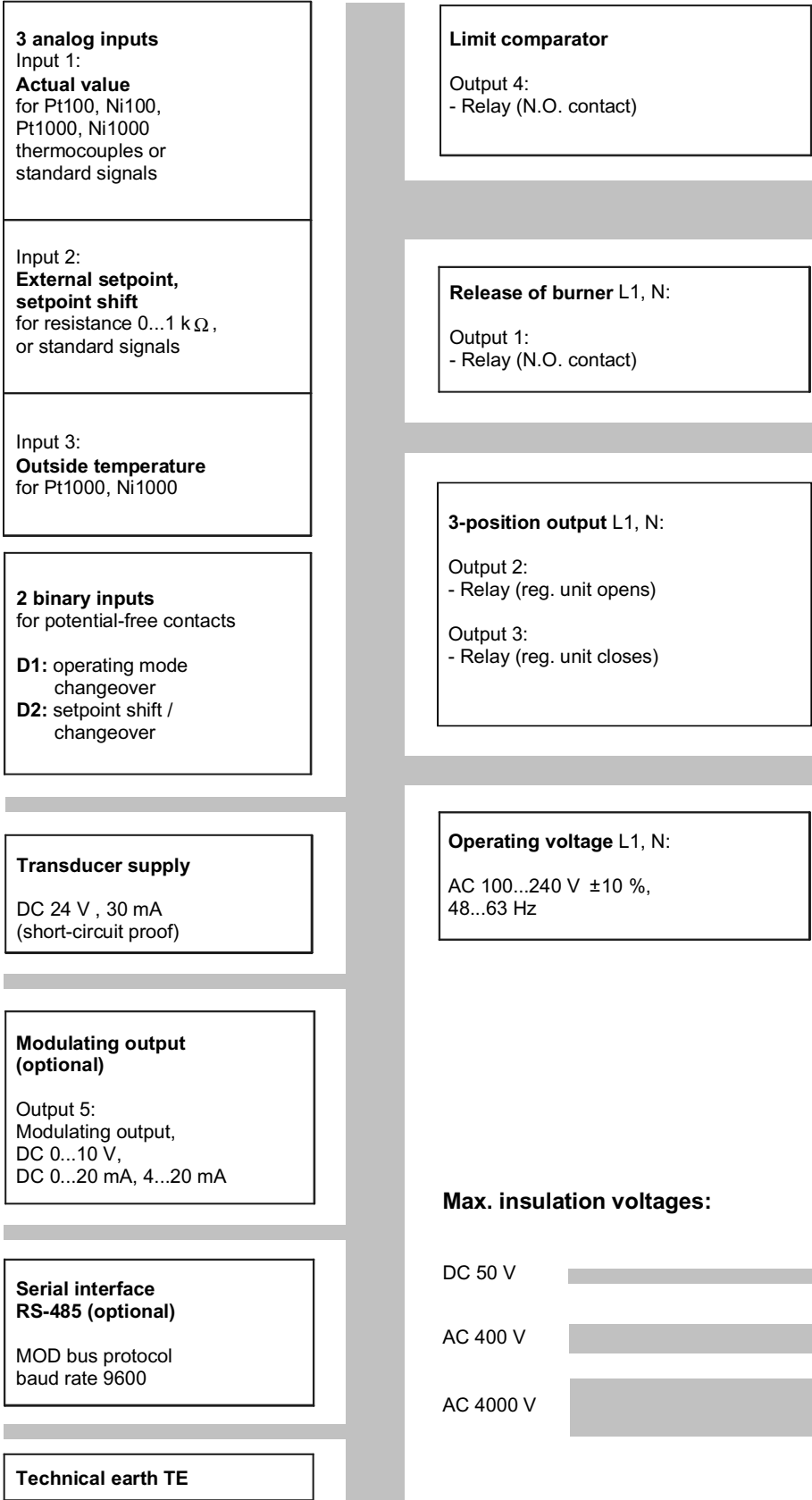

7865f07e/1299

5.1 Low-fire operation

Low-fire operation means that only small amounts of heat are drawn from the boiler. A two-position controller maintains the setpoint, switching the burner on and off like a thermostat.

Thermostat function

This control mode is therefore also known as **thermostat function**. An adjustable switching differential ensures that the switching frequency of the burner can be selected to reduce wear.

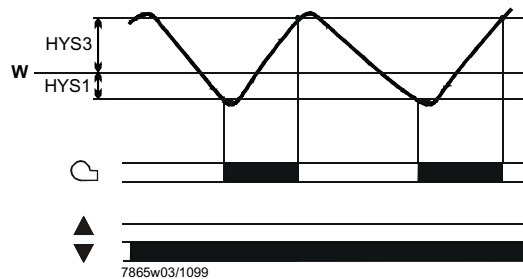

Modulating and 2-stage operation:
Actual value between «HYS1» and «HYS3»

5.2 High-fire operation

High-fire operation means that large amounts of heat are drawn from the boiler, so that the burner is on all the time. If the heating load during the thermostat operation rises to a level where the actual value begins to fall below the switch-on threshold «HYS1», the controller does not immediately switch over to a higher burner output, but first makes a dynamic test of the control deviation and only switches to the higher output when an adjustable threshold «Q» is exceeded (A).

⇒ Section 5.6 «Response threshold Q»

Operating mode changeover

- In high-fire operation, depending on the application, the burner can be fired in **modulating** or **two-stage** operation, with a larger amount of fuel than in low-fire operation. The binary input «D1» can be used to switch between modulating and two-stage operation
- When the contact is open: modulating burner operation
- When the contact is closed: two-stage burner operation

5.2.1 Modulating burner, 3-position output

In diagram area (1), the thermostat function is active. The modulating mode of burner operation is shown in area (2). In high-fire operation, a 3-position controller acts on an actuator through relay 2 (open) and relay 3 (close).

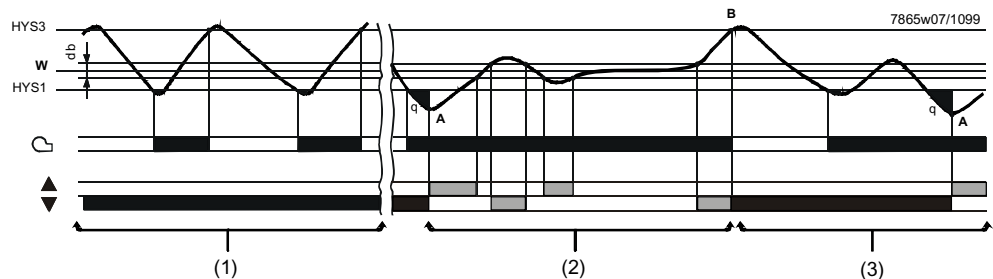

In area (3), the actual value exceeds the upper switch-off threshold «HYS3» and the controller switches off the burner (B). The controller only starts low-fire operation when the level falls below the switch-on threshold «HYS1» again. If «Q» is exceeded, the controller switches to high-fire operation (A).

⇒ Section 5.6 «Response threshold Q»

5.2.2 Modulating burner, modulating output

In diagram area (1), the thermostat function is active.

In area (2), the controller is controlling to the adjusted setpoint.

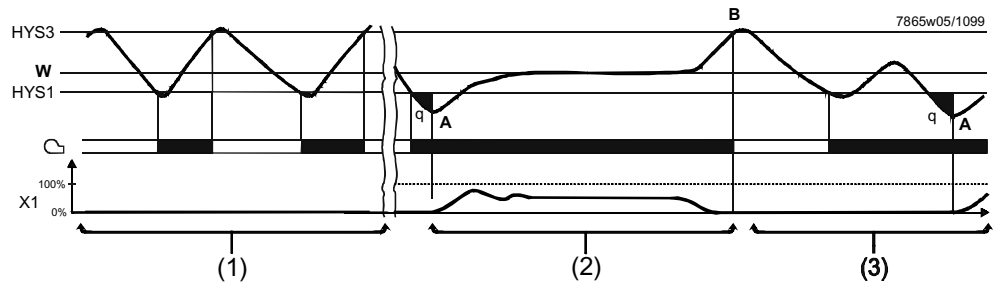

The positioning signal is delivered as a standard signal via the modulating output.



The modulating controller must be available and configured in the unit (optional).

⇒ Section 8.2 «C112 Limit comparator, controller type, setpoint «SP1», locking»

5.2.3 Two-stage burner, 3-position output

In diagram area (1), the thermostat function is active.

In area (2), a **two-position controller** acts on the second stage, via relay 2 (open) and relay 3 (close) by switching it into the circuit at the switch-on threshold «HYS1» / and out of circuit at the switch-off threshold «HYS2».

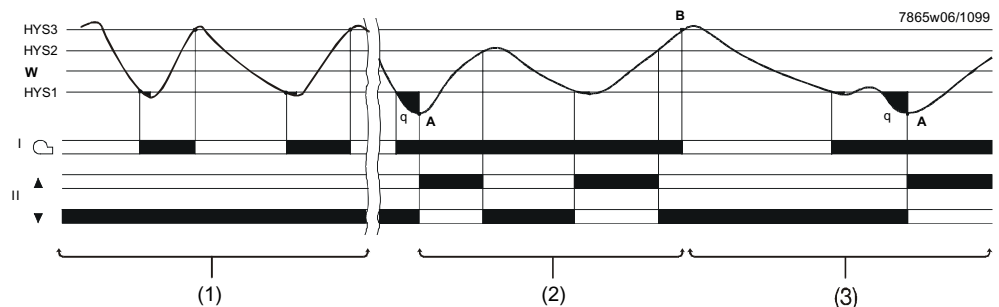

In area (3), the actual value exceeds the upper switch-off threshold «HYS3» and the controller shuts down the burner (B). The controller only starts low-fire operation when the level falls below the switch-on level «HYS1» again. If «Q» is exceeded, the controller switches to high-fire operation (A).

⇒ Section 5.6 «Response threshold Q»

5.4.1 Setpoint changeover «SP1 / SP2», analog setpoint shift



C111 and C112 are described in chapter 8

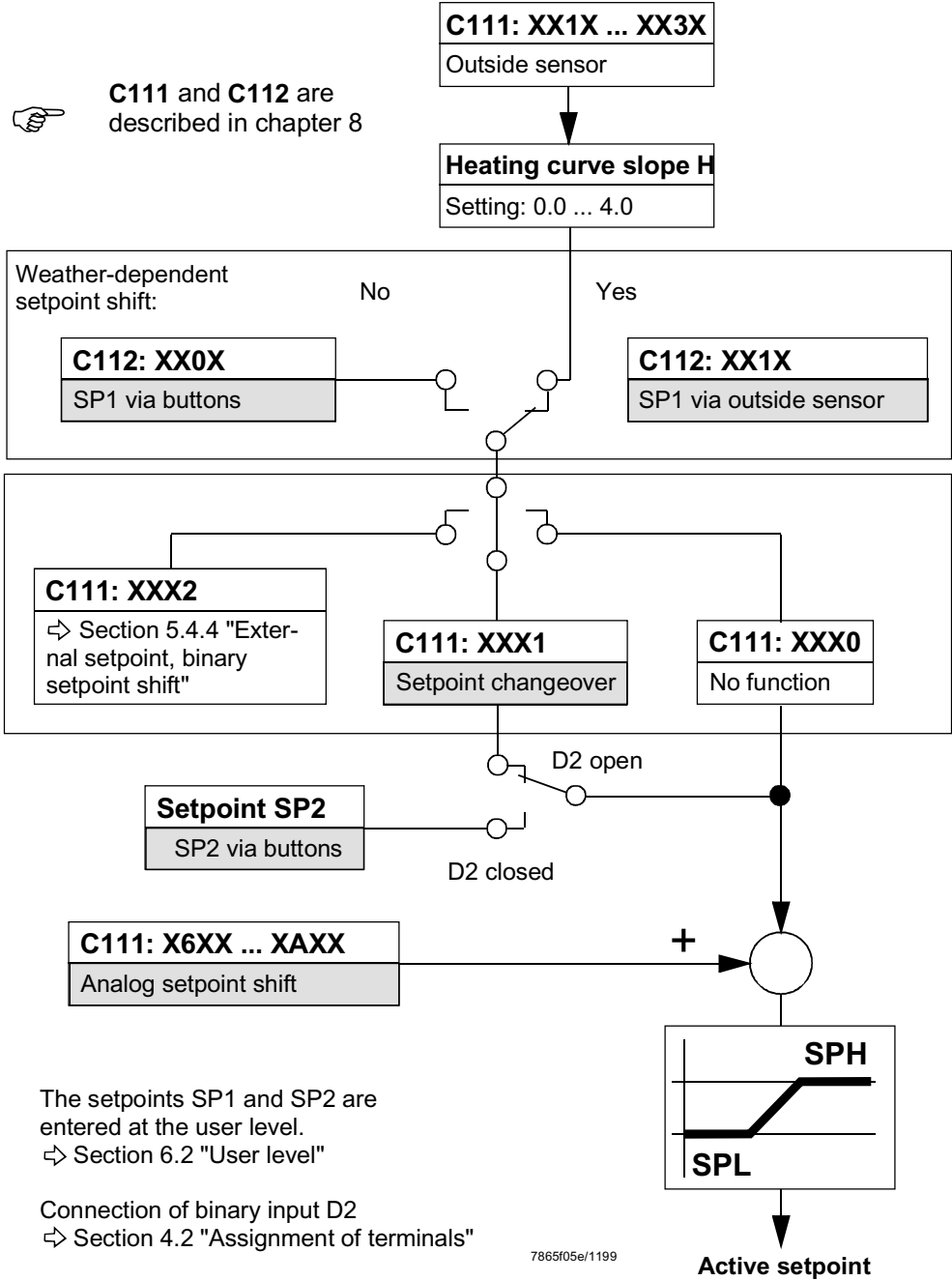

The setpoints SP1 and SP2 are entered at the user level.
 ⇨ Section 6.2 "User level"

Connection of binary input D2
 ⇨ Section 4.2 "Assignment of terminals"

7865f05e/1199

5.4.2 Setpoint changeover «SP1» / external setpoint

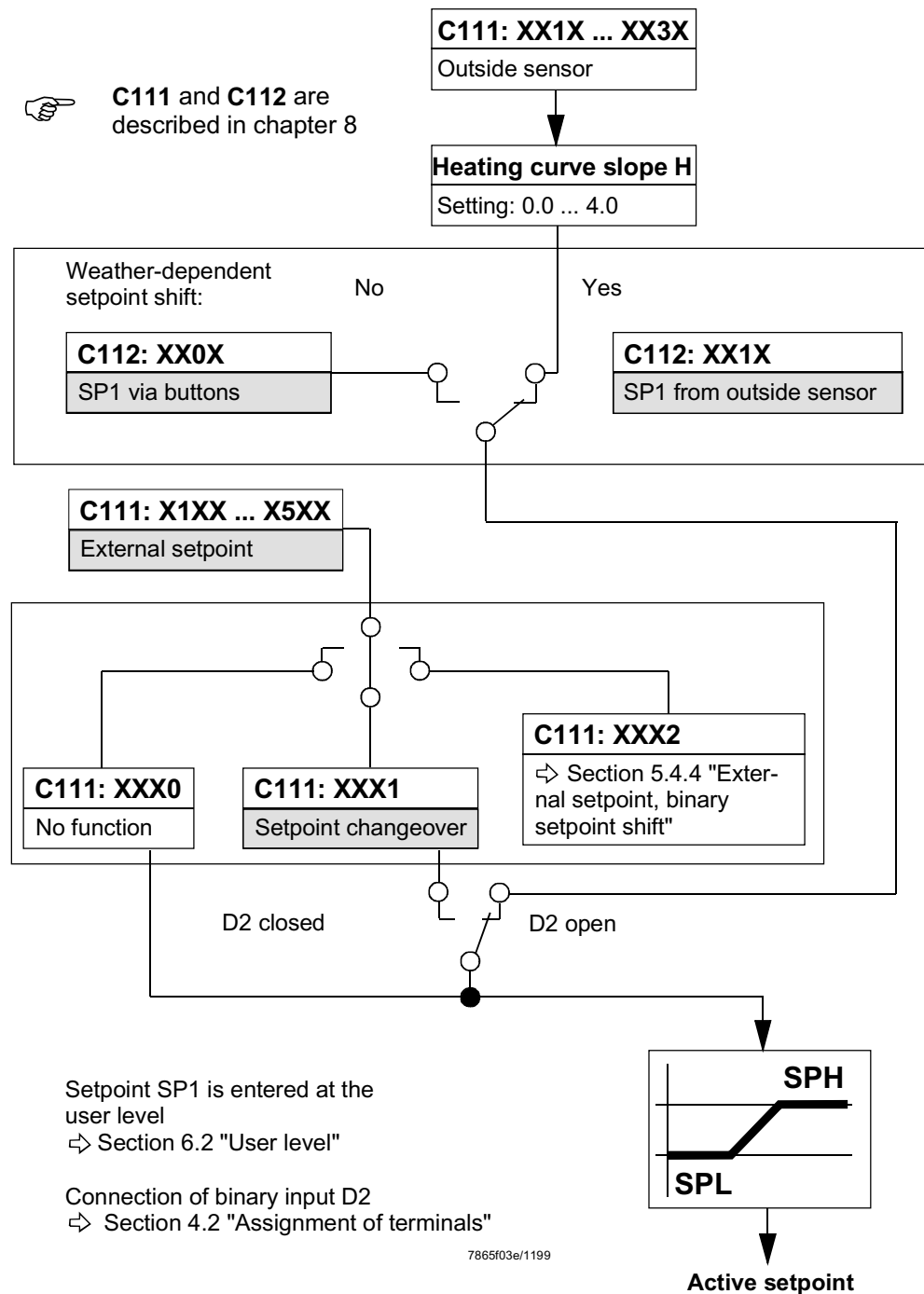

5.4.3 Setpoint «SP1», analog / binary setpoint shift

 **C111** and **C112** are described in chapter 8

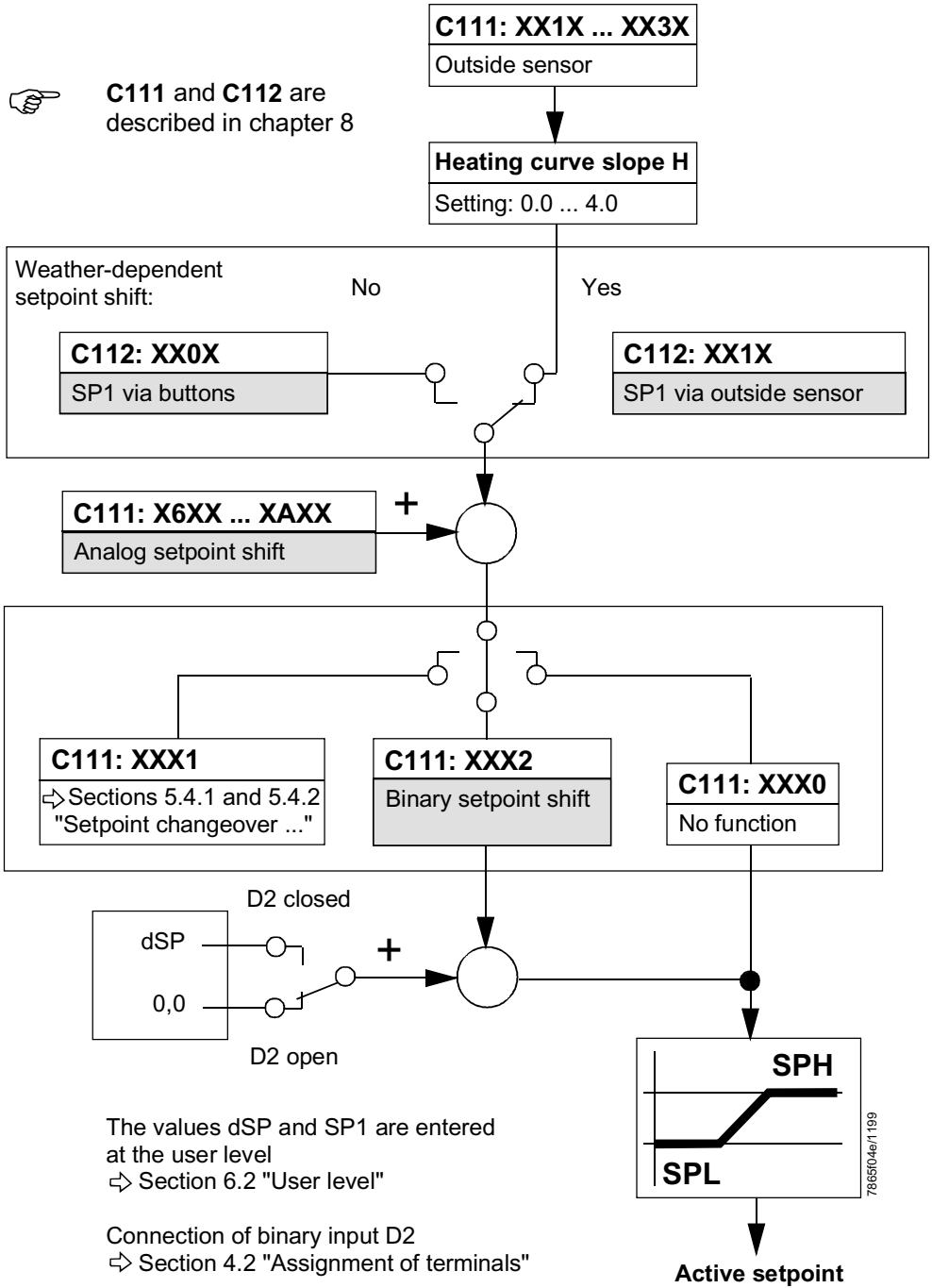

5.4.4 External setpoint, binary setpoint shift

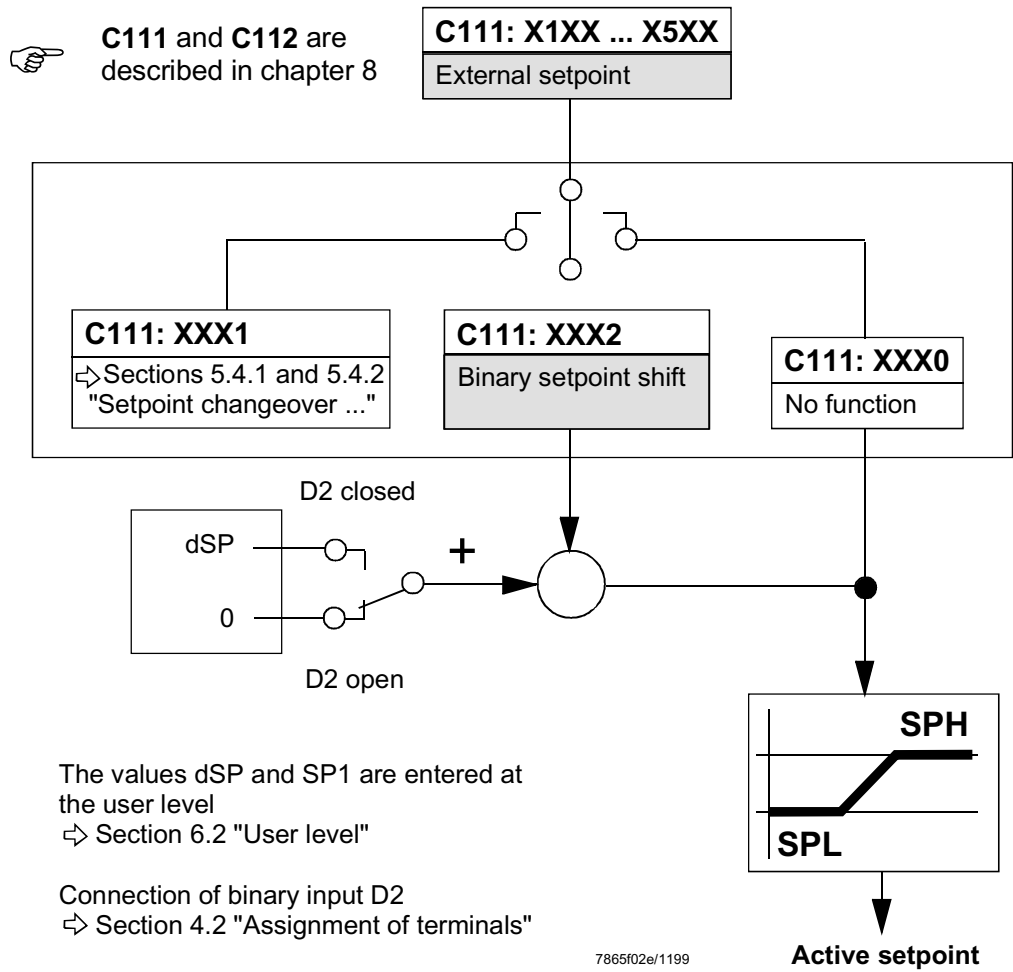

5.5 Weather-dependent setpoint shift

The RWF40... can be configured in such a way that if a Landis & Staefa Ni1000 outside sensor (e.g. QAC22) is connected, a weather-dependent setpoint shift is implemented. The minimum and maximum setpoint values can be set by the lower setpoint limit «SPL» and the upper setpoint limit «SPH». Parameter «P» can be used to apply a parallel displacement to the heating curve.



Each RWF40... must have its own separate outside sensor connected (no parallel connection)!

Parallel displacement of the heating curve

⇨ Chapter 7 «Parameter settings»

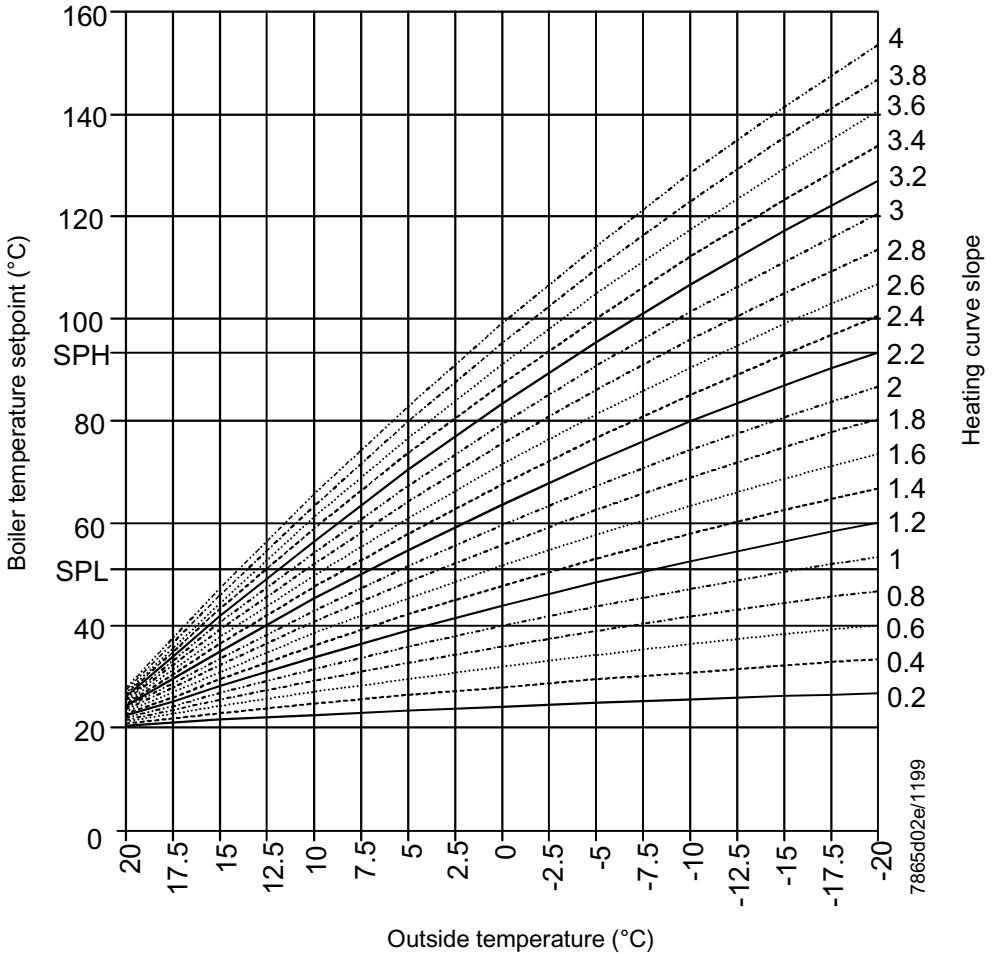

5.5.1 Heating curve slope

Slope «H» of the heating curve can be used to adjust the setpoint in response to the outside temperature, as shown in the diagram. The common origin of the heating curves is set at (20 °C / 20 °C). The effective range of the weather-adjusted setpoint is restricted by the setpoint limits «SPH» and «SPL».

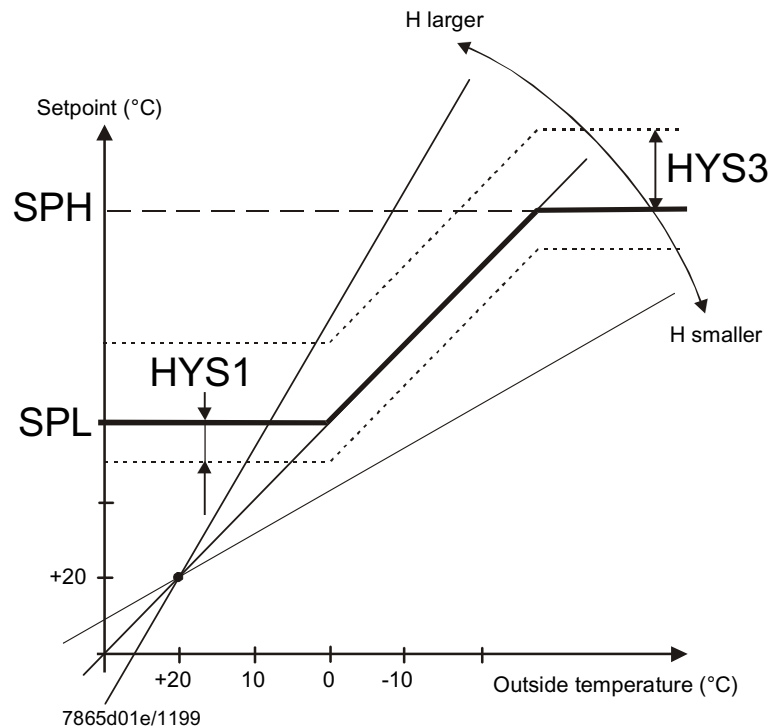

«HYS1» is the switch-on point for the burner, and «HYS3» is the switch-off point. As already described, they act with the set shift relative to the weather-controlled setpoint.

- ⇒ Section 5.2.1 «Modulating burner, 3-position output»
- ⇒ Section 5.2.2 «Modulating burner, modulating output»

5.6 Response threshold «Q»

The response threshold «Q» defines how long and how low the actual value can drop before the system switches over to high-fire operation.

An internal mathematical calculation using an integration function determines the sum of all the areas $Q_{\text{eff}} = Q_1 + Q_2 + Q_3$, as shown in the diagram. This only takes place when the control deviation $(x-w)$ falls below the value for the switching threshold «HYS1». If the actual value increases, integration is stopped.

If « Q_{eff} » exceeds the pre-set response threshold «Q» (can be adjusted at the parameter level), this causes the second stage of the burner to be switched on or - in the case of a 3-position controller / modulating controller – the regulating unit to open.

If the actual boiler temperature reaches the required setpoint, Q_{eff} is set to 0.

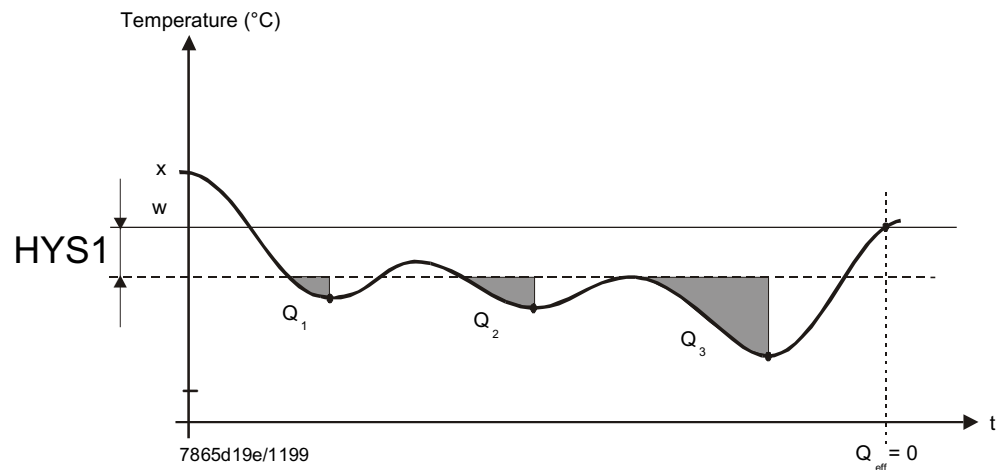

Actual value monitoring ensures that the switching frequency is kept low in the transitional range from low- to high-fire operation in order to reduce wear.

5.7 Cold start of the plant

When a heating system is switched off for a longer period of time, the actual value will fall.

To achieve a faster control response, the controller starts immediately in high-fire operation as soon as the control deviation ($x-w$) has dropped below a certain limit value. This limit is calculated as follows:

$$\text{Limit value} = 2 * (\text{HYS1} - \text{HYS3})$$

Example

Operating mode: modulating, 3-position output

HYS1 = -3 K

HYS3 = +5 K

$w = 60\text{ }^{\circ}\text{C}$

$$\text{Limit value} = 2 * (-3 - 5) = 2 * (-8) = -16\text{ K}$$

At an actual value below $44\text{ }^{\circ}\text{C}$, the heating up procedure starts immediately in high-fire operation, instead of in thermostat mode.

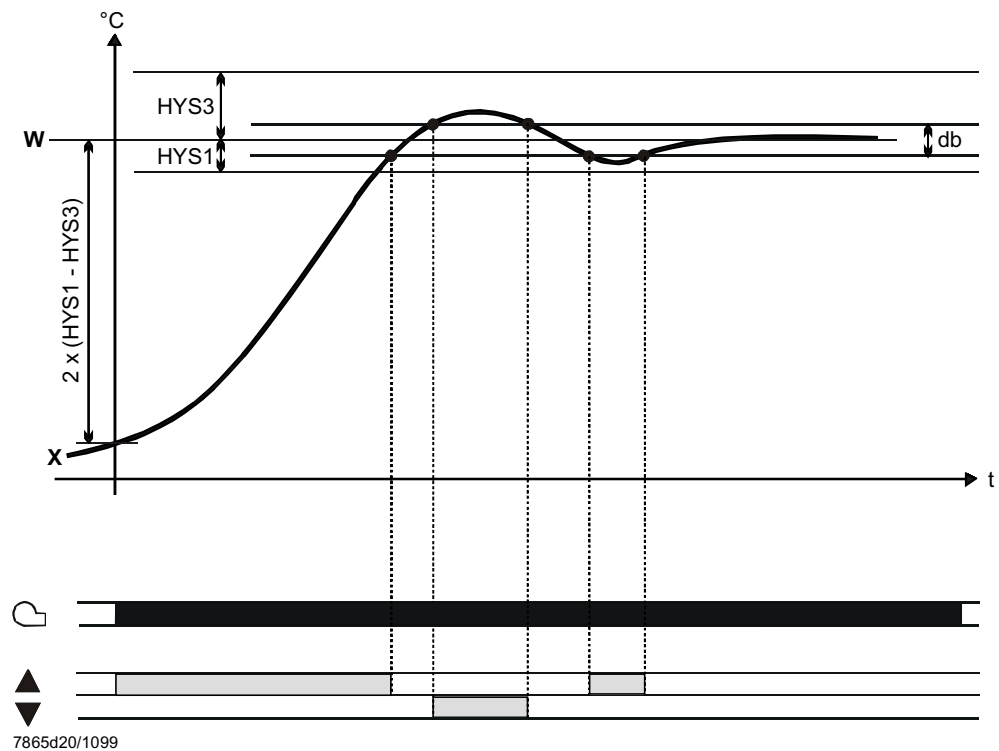

Assignment of levels

All levels can be accessed from the basic display via the **PGM** button, as shown in the diagram.
The upper actual value display (red) indicates the actual value and the parameter values for the various levels.
The setpoint and the parameters are indicated in the lower setpoint display (green).

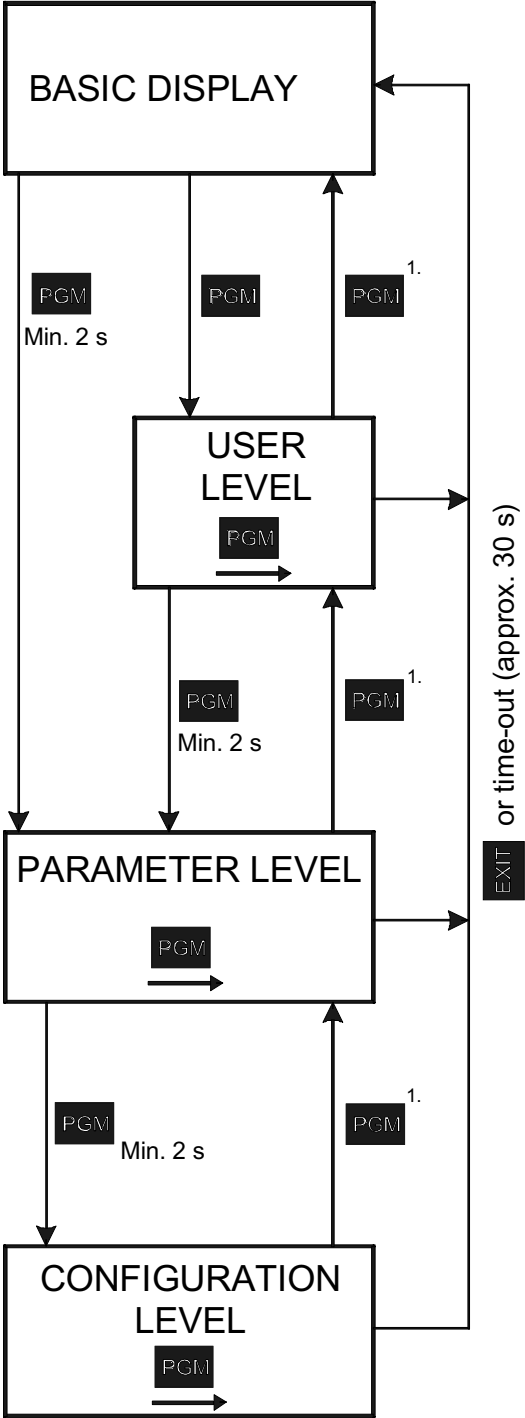

7865f08e/1299

¹⁾ After using «PGM» to step through all the parameters of a level, an automatic return occurs after the last parameter has been confirmed.

6.1 Basic display

The diagram shows the RWF40... after switching on power. This condition is called the basic display. The actual value and the currently active setpoint are shown here. Manual operation, self-setting, the user, parameter and configuration levels can be activated from here.

6.1.1 Meaning of the display and buttons

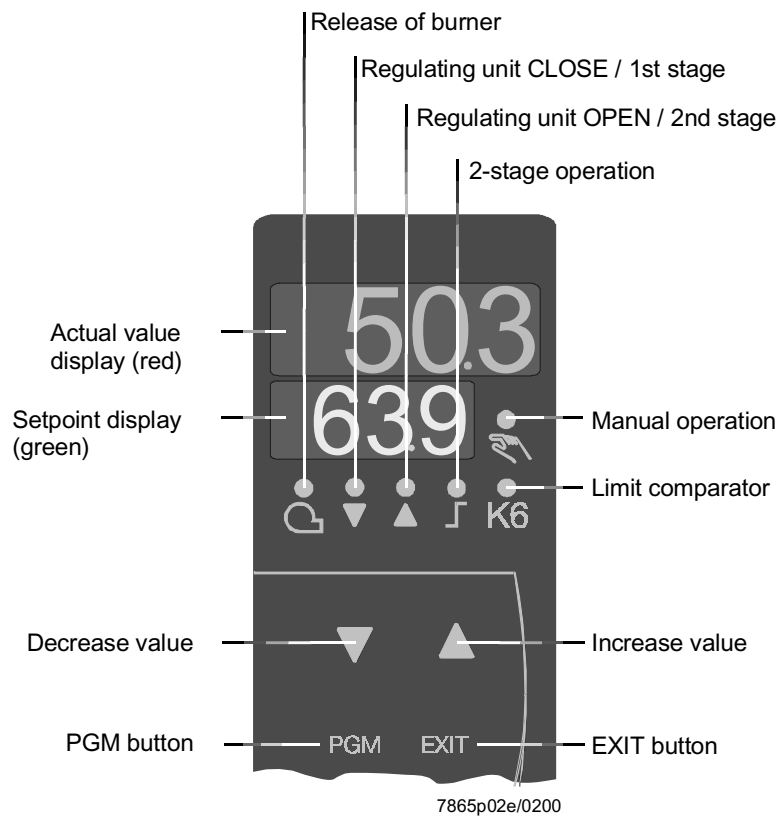



Initialization	All displays are lit up; the setpoint display flashes for about 10 seconds after switching on power.
Manual operation	The actual value is indicated on the upper display. The LED for manual operation is on. Depending on the operating mode and the type of controller, the setpoint or the level of the manual actuator position is shown on the setpoint display (green). ⇒ Section 6.2.2 «Manual operation of a modulating burner»
Self-setting function	The actual value is shown on the actual value display (red) and the text « tunE » flashes on the setpoint display (green). ⇒ Section 9.1 «Self-setting function in high-fire operation»
Actual value display flashes	⇒ Chapter 10 «What to do if...»
2-stage operation	⇒ Section 5.2 «High-fire operation»
Time-out	 If there is no action by the operator, the controller returns automatically to the basic display after about 30 seconds.

6.2 User level

This level is started from the basic display. Setpoints «SP1», «SP2 / dSP» can be altered, and the analog inputs «E2» (external setpoint / setpoint shift) and «E3» (outside temperature) can be displayed.

6.2.1 Changing the setpoints

To alter «SP1», «SP2» or «dSP»:

- * Change to the user level with 
- * Alter the setpoint «SP1» with ▼ and ▲
- * Change to setpoint «SP2» or «dSP» with 
- * Alter the setpoint «SP2» or «dSP» with ▼ and ▲
- * Return to the basic display with  or automatically by time-out after about 30 s

 After 2 seconds, the value that is set will automatically be adopted. The value can only change within the permitted value range

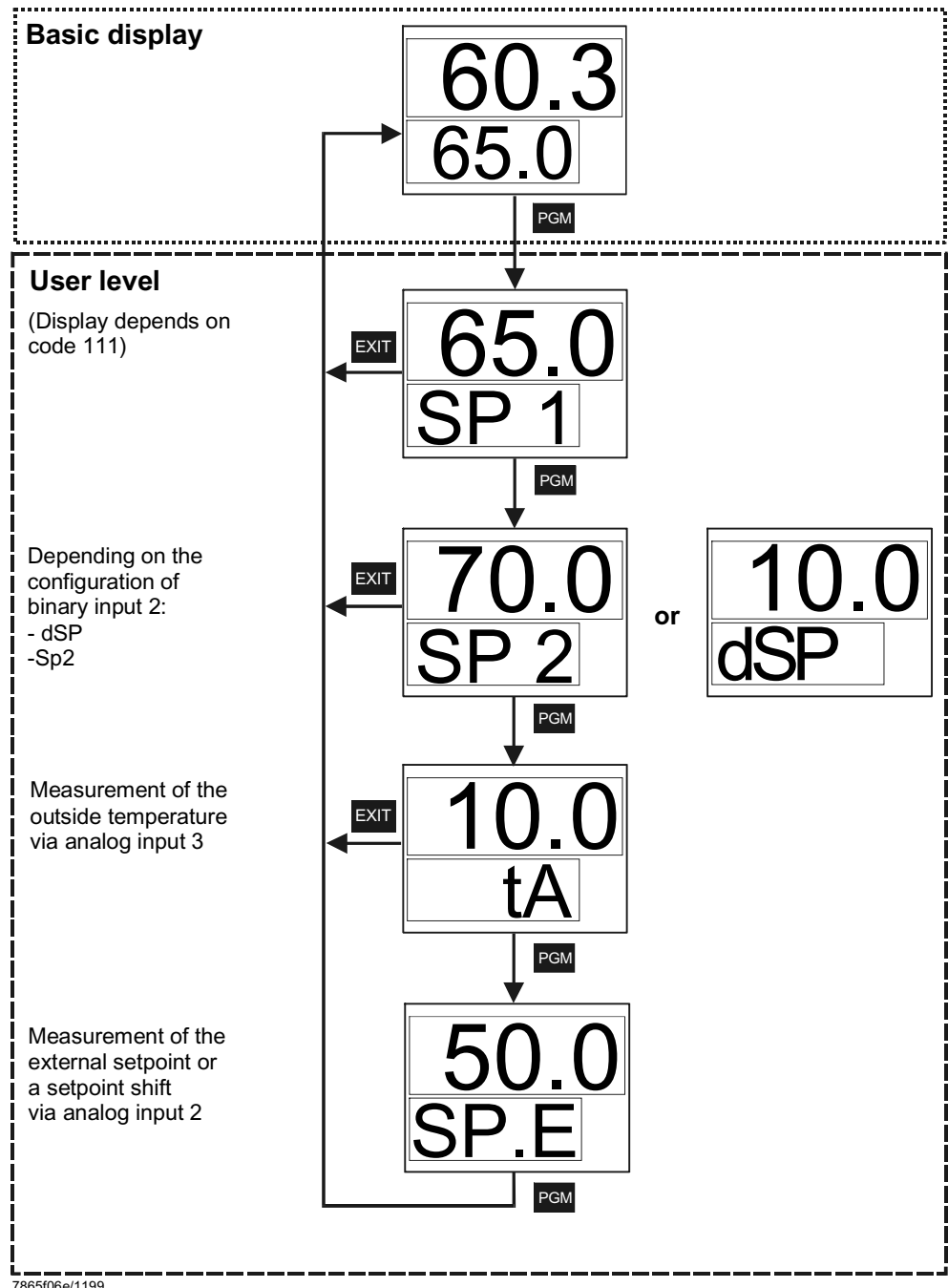

6.2.2 Manual operation, modulating burner

* Press **EXIT** for 5 s

The LED above the hand symbol lights up.

3-position controller

* Change the regulating unit's position with ▲ and ▼

Relay 2 opens the regulating unit as long as ▲ is pressed.

Relay 3 closes the regulating unit as long as ▼ is pressed.

The LEDs for the regulating units indicate if «OPEN» or «CLOSE» is activated.

Modulating controller

* Change the regulating unit's position with ▲ and ▼

The modulating output delivers the regulating unit's position that was entered.

* Return to automatic operation by pressing **EXIT** for 5 s



When manual operation is activated, the regulating unit's position is set to 0 until another entry with the buttons is made.

Thermostat mode

Manual operation can only be activated if the thermostat function has set relay 1 to **active**.

If the thermostat function sets relay 1 to **inactive** during manual operation, manual operation is terminated.

6.2.3 Manual operation, two-stage burner

* Press **EXIT** for 5 s

* Press ▲ briefly

– Relay 2 is active, relay 3 is inactive

– Analog output (optional) delivers DC 10 V

The regulating unit opens

* Or press ▼ briefly

– Relay 2 is inactive, relay 3 is active

– Analog output (optional) delivers DC 0 V

The regulating unit closes

* Return to automatic operation by pressing **EXIT** for 5 s



If the thermostat function sets relay 1 to **inactive** during manual operation, manual operation is terminated.

6.2.4 Start self-setting

* Start self-setting with **PGM** + ▼

* Cancel with ▲

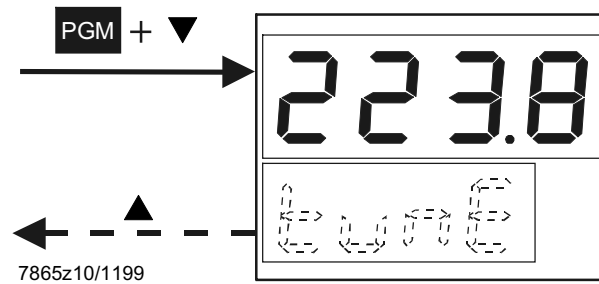

When «**tunE**» stops flashing, self-setting has stopped.

* Accept the parameters that have been determined by pressing ▲ (press the button for at least 2 s!)



It is not possible to start «**tunE**» in manual operation or thermostat operation.

6.2.5 Display of the software version and unit of actual value

* Press **PGM** + ▲

Available units:

°C, °F and % (for standard signals)

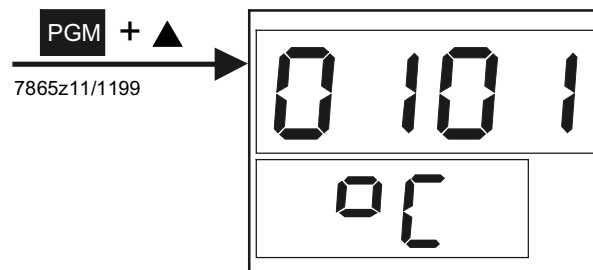

6.3 Parameter level

The parameters involved in the adaptation of the controller to the controlled system are set here after the system has been started up.

Within the level, you can proceed to the next parameter by pressing **PGM**.



The display of the individual parameters depends on the type of controller.

6.3.1 Enter parameters

The entry and alteration of parameters is made through a continuous alteration of the value. The longer you keep the button pressed, the faster the rate of change becomes.

* Increase value by pressing ▲

* Reduce value by pressing ▼

* Accept entry by pressing **PGM**

or

* Cancel entry by pressing **EXIT**



After 2 seconds, the value that is set will automatically be accepted. The value can only change within the permitted value range.

⇒ Chapter 7 «Parameter settings»

6.4 Configuration level

The settings made here are those required for commissioning a specific installation and therefore rarely need to be altered, such as acquisition of measured value or type of controller.

Within the level, you can proceed to the next parameter by pressing **PGM**.

6.4.1 Changing the configuration code

* Select position by pressing ▼ (position flashes!)

* Alter value by pressing ▲

* Accept code by pressing **PGM**

or

* Cancel entry by pressing **EXIT**

⇒ Chapter 8 «Configuration»

7. Parameter settings

The parameter is shown on the lower setpoint display (green) and the value on the upper / actual value display (red).

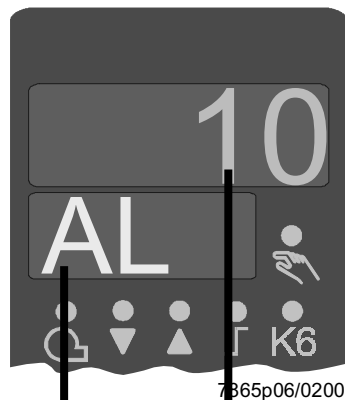

Parameter	Display	Value range	Factory setting	Remarks
Limit value for limit comparator ¹⁾	AL	-1999...+9999 digit	0	<p>⇒ Chapter 8.2 «C112 – limit comparator, controller type, setpoint «SP1», locking»</p>
Switching differential for limit comparator ¹⁾	HYSt	0...999.9 digit	1	<p>Switching differential at the edges for the limit comparators</p> <p>⇒ Chapter 8.2 «C112 – limit comparator, controller type, setpoint «SP1», locking»</p>
Proportional band ¹⁾	Pb.1	0.1...999.9 digit	10	Affects the P-response of the controller
Derivative time	dt	0...9999 s	80	<p>Affects the D-response of the controller. Within $dt = 0$, the controller has no D-response.</p> <p>For modulating controllers, $dt = rt / 4$ or 0 must be entered.</p>
Integral action time	rt	0...9999 s	350	Affects the I-response of the controller. With $rt = 0$, the controller has no I-response
Contact spacing (dead band) ¹⁾	db	0...999.9 digit	1	<p>For 3-position output</p>

¹⁾ This parameter is affected by the setting of the decimal place.

7. Parameter settings

The parameter is shown on the lower / setpoint display (green) and the value on the upper / actual value display (red).

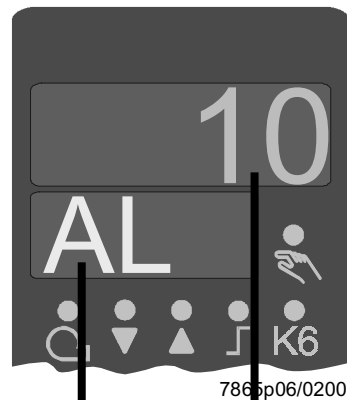

Parameter	Display	Value range	Factory setting	Remarks
Actuator running time	tt	10...3000 s	15 s	Utilized running time of the valve for 3-position controllers
Switch-on threshold for burner stage II ¹⁾	HYS 1	0...-199.9 digit	-5	⇒ Section 5.5.1 «Heating curve slope»
Switch-off threshold stage II ¹⁾	HYS 2	0...HYS3 digit	3	⇒ Section 5.2 «High-fire operation»
Upper switch-off threshold ¹⁾	HYS 3	0...999.9 digit	5	⇒ Section 5.2 «High-fire operation»
Response threshold	q	0...999.9	0	⇒ Section 5.6 «Response threshold Q»
Heating curve slope	H	0...4	1	⇒ Section 5.5.1 «Heating curve slope»
Parallel displacement ¹⁾	P	-90...+90	0	⇒ Section 5.5 «Weather-dependent setpoint shift»

¹⁾ This parameter is affected by the setting of the decimal place.

8.1 C111 inputs

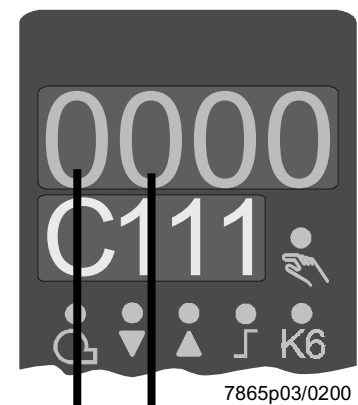

7865p03/0200

Analog input 1

Pt100, 3-wire	0
Pt100, 2-wire	1
Ni100, 3-wire	2
Ni100, 2-wire	3
Pt1000, 3-wire, Landis & Staefa IEC 751	4
Pt1000, 2-wire, Landis & Staefa IEC 751	5
Ni1000, 3-wire, DIN 43760	6
Ni1000, 2-wire, DIN 43760	7
Ni1000, 3-wire, Landis & Staefa	8
Ni1000, 2-wire, Landis & Staefa	9
NiCr-Ni / K	A
Cu-CuNi / T	b
NiCroSil-NiSil / N	C
Fe-CuNi / J	d
Standard signal DC 0...20 mA	E
Standard signal DC 4...20 mA	F
Standard signal DC 0...10 V	G
Standard signal DC 0...1 V	H

Analog input 2

No function	0
External setpoint, 1 k Ω resistance potentiometer	1
External setpoint, DC 0...20 mA	2
External setpoint, DC 4...20 mA	3
External setpoint, DC 0...10 V	4
External setpoint, DC 0...1 V	5
Analog setpoint shift, 1 k Ω resistance potentiometer	6
Analog setpoint shift, DC 0...20 mA	7
Analog setpoint shift, DC 4...20 mA	8
Analog setpoint shift, DC 0...10 V	9
Analog setpoint shift, DC 0...1 V	A

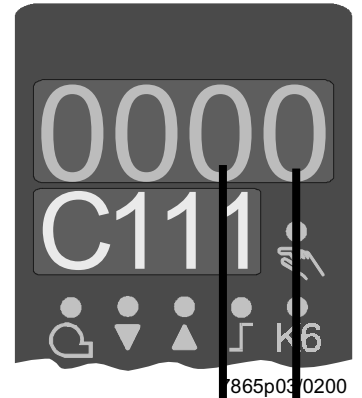

865p0370200

Analog input 3

No function	0
Outside sensor Pt1000, 2-wire, Landis & Staefa IEC 751	1
Outside sensor Ni1000, 2-wire, DIN 43760	2
Outside sensor Ni1000, 2-wire, Landis & Staefa	3

Function of binary input «D2»

No function	0
Setpoint changeover	1
Setpoint shift (binary)	2

Factory setting	9	0	3	0
------------------------	----------	----------	----------	----------

8.2 C112 limit comparator, controller type, setpoint «SP1», locking

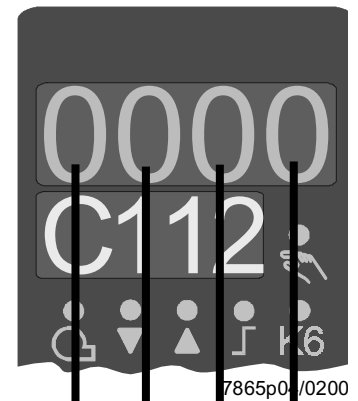

Limit comparator

No function (lk off)	0
lk1, input 1	1
lk2, input 1	2
lk3, input 1	3
lk4, input 1	4
lk5, input 1	5
lk6, input 1	6
lk7, input 1	7
lk8, input 1	8
lk7, input 2	9
lk8, input 2	A
lk7, input 3	b
lk8, input 3	C

Controller type

3-position controller	0
Modulating controller DC 0...20 mA	1
Modulating controller DC 4...20 mA	2
Modulating controller DC 0...10 V	3

Setpoint «SP1»

«SP1» via buttons	0
«SP1» with outside sensor (analog input 3 must be configured)	1

Locking

No locking	0
Locking of configuration level	1
Locking of parameter level	2
Locking of buttons	3



Locking of the buttons can be entered only **once** and adapted with **PGM**. After this, all button operations are locked and can only be enabled again by the manufacturer!

Factory setting	0 0 1 0
------------------------	----------------

Function Ik1

Window function: relay «K6» is active when the measured value lies within a window around the setpoint (w).

Example: $w = 80\text{ }^{\circ}\text{C}$, $AL = 5$, $HYSt = 2$

Measured value rising: relay «K6» switches on at $76\text{ }^{\circ}\text{C}$ and off at $86\text{ }^{\circ}\text{C}$.

Measured value falling: relay «K6» switches on at $84\text{ }^{\circ}\text{C}$ and off at $74\text{ }^{\circ}\text{C}$.

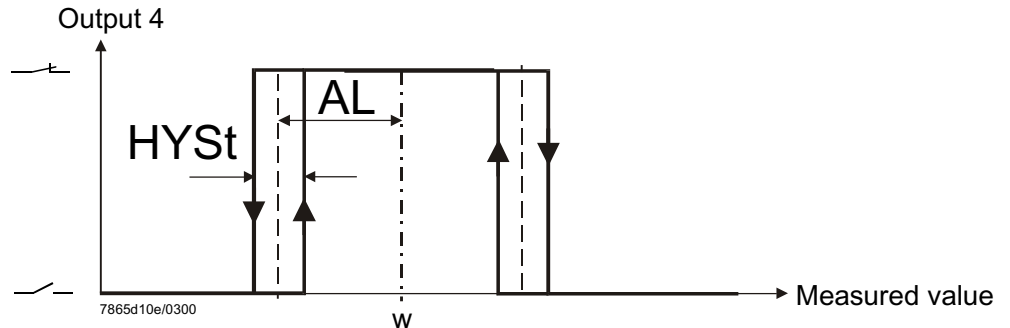

Function Ik2

As for Ik1, but with inverted switching function.

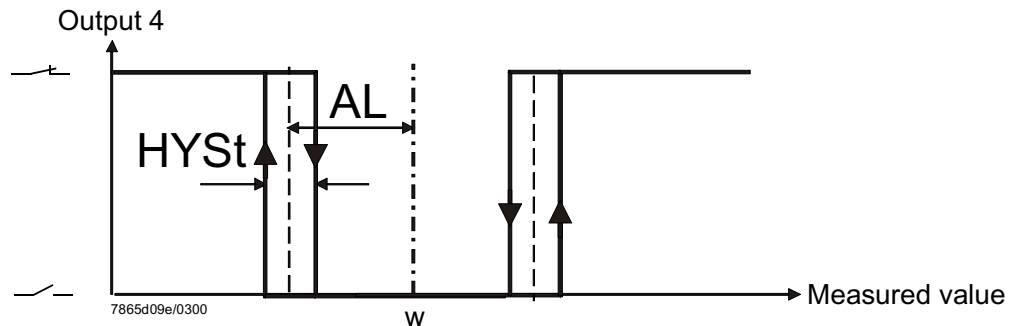

HYSt = switching differential of the window edges

AL = interval from setpoint (half the window-width)

Function Ik3

Lower limit signaling

Function: relay inactive when measured value $<$ (setpoint – limit value).

Example: $w = 80\text{ }^{\circ}\text{C}$, $AL = 10$, $HYSt = 2$

Measured value rising: relay «K6» switches on at $71\text{ }^{\circ}\text{C}$.

Measured value falling: relay «K6» switches off at $69\text{ }^{\circ}\text{C}$.

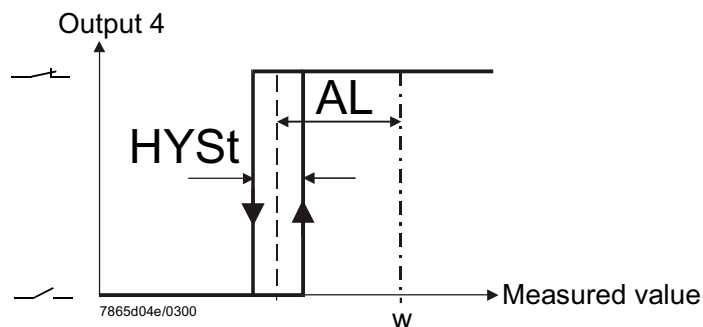

Function Ik4

As for Ik3, but with inverted switching function.

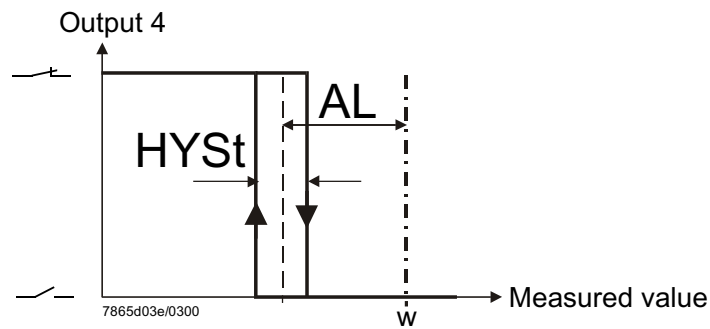

HYSt = switching differential

AL = interval from setpoint

⇒ Chapter 7 «Parameter settings»

Function Ik5

Upper limit signaling

Function: relay inactive when measured value > (setpoint + limit value).

Example: $w = 80\text{ °C}$, **AL** = 10, **HYSt** = 2

Measured value rising: relay «K6» switches off at 91 °C .

Measured value falling: relay «K6» switches on at 89 °C .

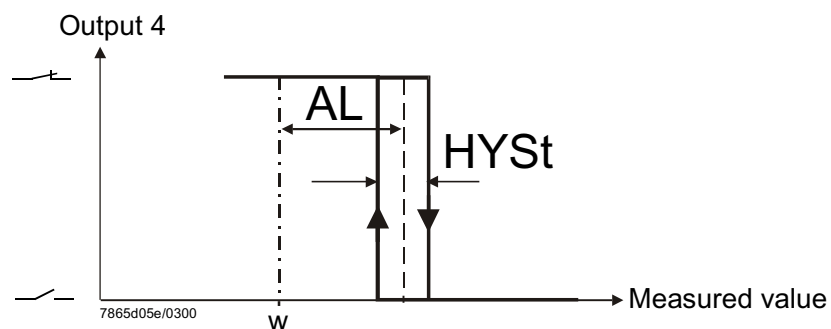

Function Ik6

As for Ik5, but inverted switching function.

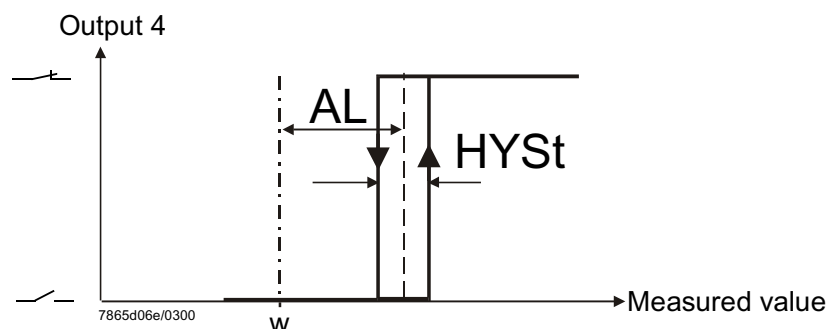

Function Ik7

The switching point is independent of the controller setpoint; only the limit value «AL» determines the switching point.

Function: relay is active when measured value > limit value.

Example: **AL** = 50, **HYSt** = 2

Measured value rising: relay «K6» switches on at 51 °C.

Measured value falling: relay «K6» switches off at 49 °C.

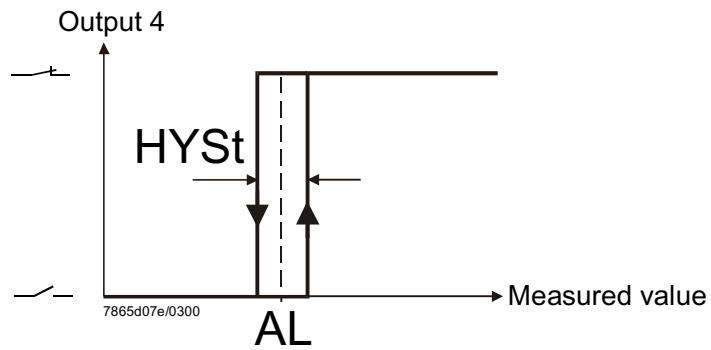

Function Ik8

As for Ik7, but with inverted switching function.

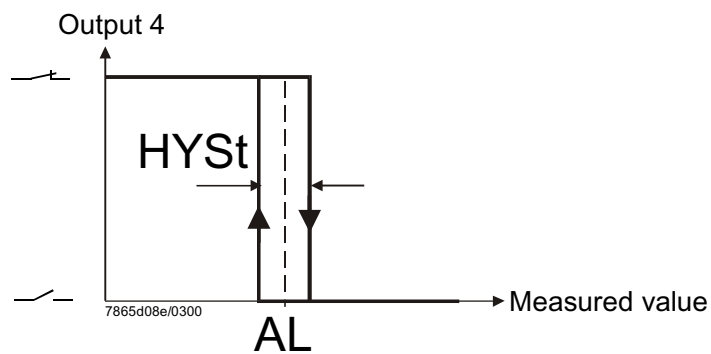

HYSt = switching differential

AL = limit value

⇒ Chapter 7 «Parameter settings»

8.3 C113 instrument address, dimensional unit, out-of-range



The setting for the decimal place affects actual value-dependent parameters!

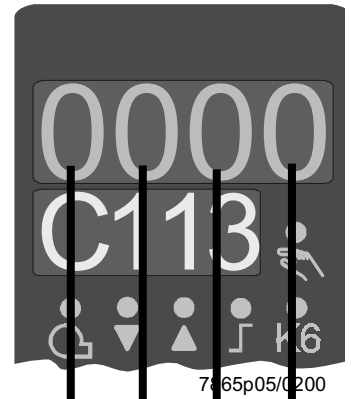

Unit address

Address 0	0	0
Address 1	0	1
...	...	
Address 99	9	9

Decimal places, dimensional unit

No decimal place, °C	0
One decimal place, °C	1
No decimal place, °F	2
One decimal place, °F	3

Signal for out-of-range

Limit comparators OFF	0
Limit comparators ON	1

Factory setting	0	1	1	0
------------------------	----------	----------	----------	----------

8.3.1 «SCL» scaling of standard signal range start, analog input 1

Example

SCL = 20; SCH = 100 °C

0 mA (start) corresponds to a measured value of 20 °C

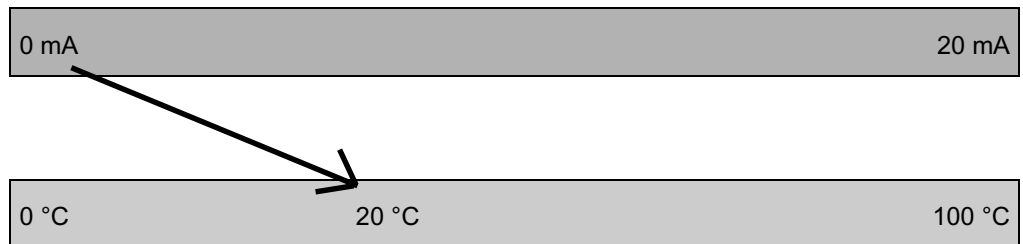

Value range: -1999...+9999 digit

Factory setting: 0 digit

8.3.2 «SCH» scaling of standard signal range end, analog input 1

Example

SCH = 80; SCL = 0 °C

20 mA (end) corresponds to a measured value of 80 °C

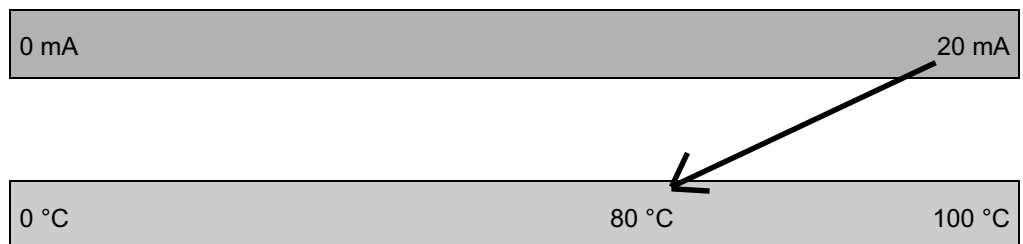

Value range: -1999...+9999 digit

Factory setting: 100 digit

8.3.3 «SCL2» scaling of standard signal range start, analog input 2

Example

SCL2 = 20:

0 mA corresponds to a measured value of 20 °C, as already described

Value range: -1999...+9999 digit

Factory setting: 0 digit

8.3.4 «SCH2» scaling of standard signal range end, analog input 2

Example

SCH2 = 80:

20 mA corresponds to a measured value of 80 °C, as already described

Value range: -1999...+9999 digit

Factory setting: 100 digit

8.3.5 «SPL» lower setpoint limit

The controller restricts the setpoints to the value that is set.

Value range: -1999...+9999 digit

Factory setting: 0 digit

8.3.6 «SPH» upper setpoint limit

The controller restricts the setpoints to the value that is set.

Value range: -1999...+9999 digit

Factory setting: 100 digit

8.3.7 «OFF1» actual value correction for analog input 1

The actual value correction can be used for correction of the measured value upwards or downwards by a specific amount. It is also used for line compensation when resistance thermometers are connected in a 2-wire circuit.

Value range: -1999...+9999 digit

Factory setting: 0 digit

Example

Measured value	Offset	Displayed value
294.7	+0.3	295
295.3	-0.3	295

8.3.8 «OFF2» actual value correction for analog input 2

Value range: -1999...+9999 digit

Factory setting: 0 digit

8.3.9 «OFF3» actual value correction for analog input 3

Value range: -1999...+9999 digit

Factory setting: 0 digit

8.3.10 «dF1» 2nd order digital filter for analog input 1

Value range for filter time constant: 0...100 s

Factory setting: 1 s

9.1 Self-setting function in high-fire operation

☞ «**tunE**» is only possible in high-fire operation, in the «modulating burner» mode.

The self-setting function «**tunE**» is a pure software function unit that is integrated into the controller. In the «modulating» mode of operation, «**tunE**» tests the response of the controlled system to steps of the positioning signal according to a special procedure. A complex control algorithm uses the response of the controlled system (actual value) to calculate and store the control parameters for a PID or PI controller (set $dt = 0!$). The «**tunE**» procedure can be repeated as often as required.

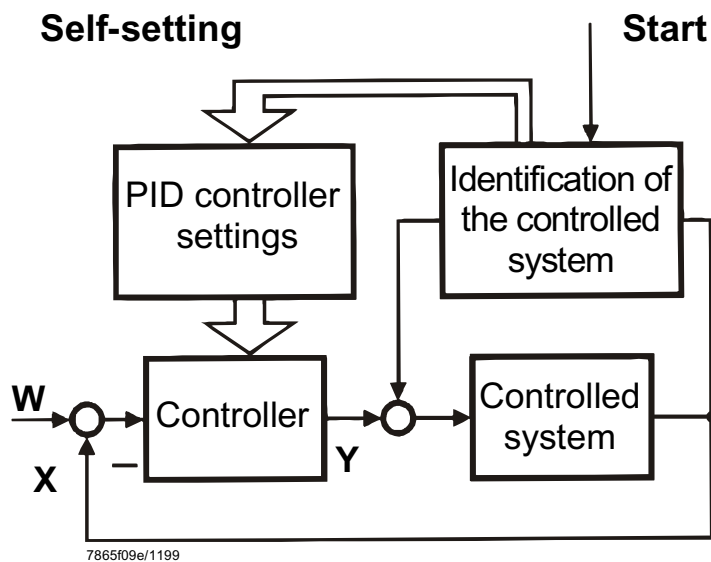

Two procedures

The «**tunE**» function uses two different methods that are automatically selected depending on the dynamic state of the actual value and the difference from the setpoint at the start. «**tunE**» can be started from within any dynamic actual value sequence. If there is a **large difference between actual value and setpoint** when «**tunE**» is activated, a switching line is established around which the controlled variable performs forced oscillations during the self-setting procedure. The switching line is set at such a level that the actual value should not exceed the setpoint.

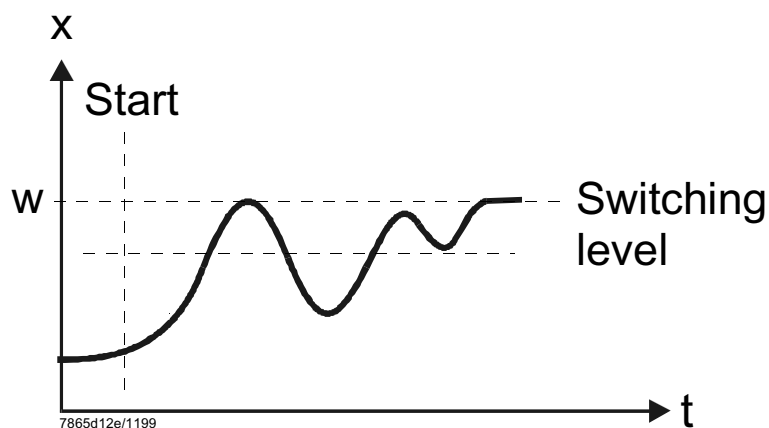

With a **small deviation** between setpoint and actual value, for instance when the controlled system has stabilized, a forced oscillation is performed around the setpoint.

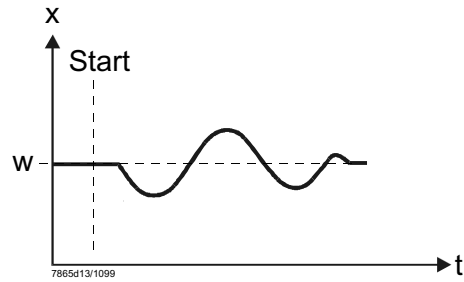

The controlled system data which are recorded for the forced oscillations are used to calculate the controller parameters «rt, dt, Pb.1» and a filter time constant for actual value filtering that is optimized for this controlled system.

Conditions

- High-fire operation in the «modulating burner» mode.
- The thermostat function (relay 1) must be constantly activated, otherwise «**tunE**» will be cancelled and no optimized controller parameters will be adapted
- The above mentioned actual value oscillations during self-setting may not exceed the upper threshold of the thermostat function (increase if necessary, and lower the setpoint)

9.2 Checking the controller parameters

The optimum adjustment of the controller to the controlled system can be checked by recording a startup sequence with the control loop closed. The following diagrams indicate possible incorrect adjustments, and their correction.

Example

The response to a setpoint change is shown here for a 3rd order controlled system for a PID controller. The method used for adjusting the controller parameters can, however, also be applied to other controlled systems.

A favourable value for «dt» is «rt» / 4.

«PB too small»

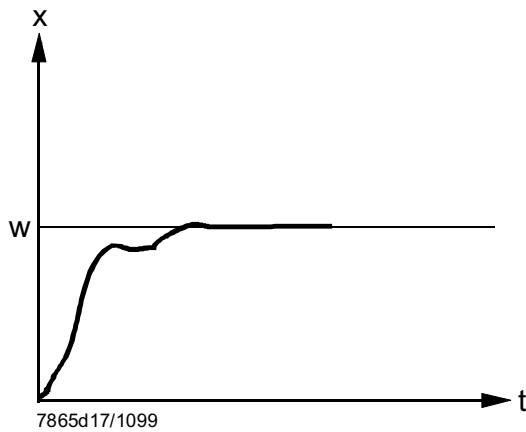

«PB too large»

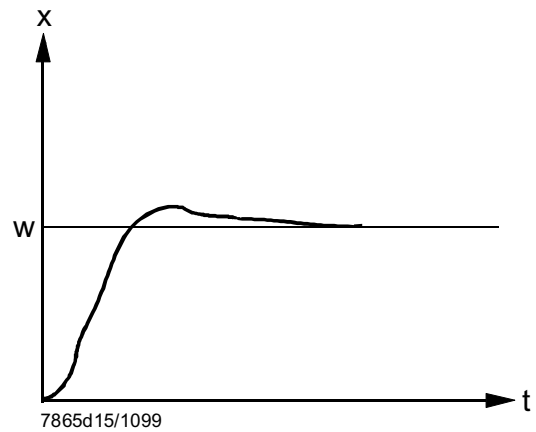

«rt, dt» too small

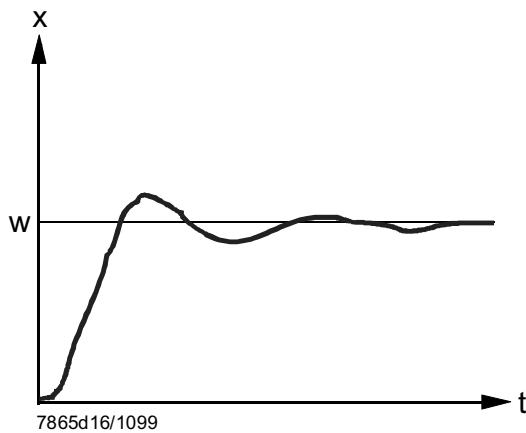

«rt, dt» too large

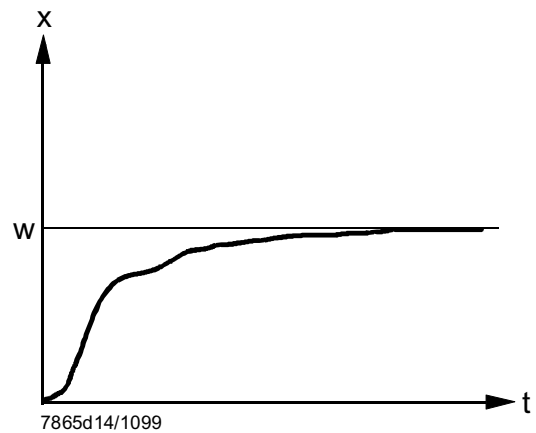

Optimum adjustment

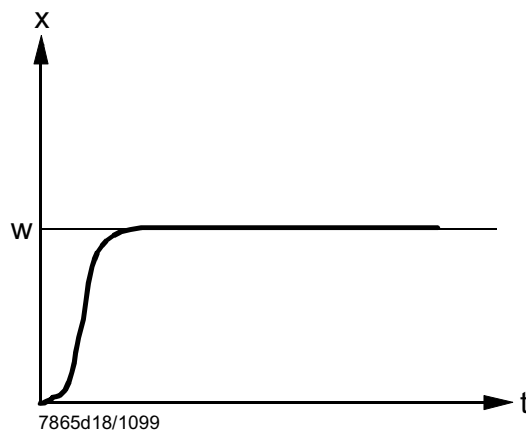







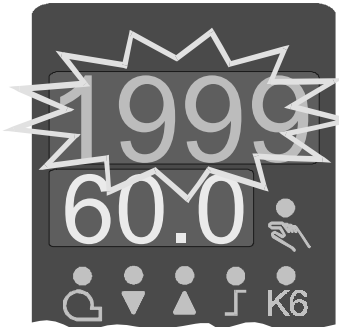

10.1 ...numbers are flashing on the display

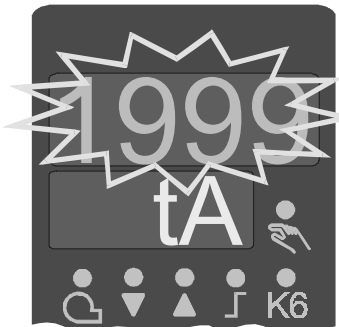
This is an indication that a measured value is not being acquired correctly.

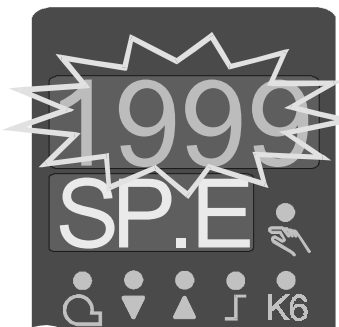
 The detection of measured value range crossings depends on the type of sensor used.

⇒ Section 11.3.2 «Measured value circuit monitoring»

Display	Description		Cause / controller behavior / remedy
 <p style="text-align: right; font-size: small;">7865p08/0200</p>	<p>Actual value display (red) shows «1999» flashing. Setpoint display shows the setpoint.</p>		<p>Overrange or underrange on analog input 1. The actual value is not being measured. Controller initiates lockout. ⇒ Section 5.3 «Safety shutdown»</p> <p>The limit comparator responds to analog input 1 according to the configuration (C113).</p> <p>* Check the electrical connections for open-circuit of sensor</p>
 <p style="text-align: right; font-size: small;">7865p10/0200</p>	<p>When analog input 3 is configured for outside temperature (C111) and the measured value is called up, the actual value display (red) shows «1999» flashing.</p>		<p>Overrange or underrange on analog input 3. The outside temperature is not being measured! The weather-dependent setpoint is inactive!</p> <p>* Check the electrical connections for open-circuit of sensors</p>
 <p style="text-align: right; font-size: small;">7865p09/0200</p>	<p>When analog input 2 is configured (C111) and the measured value is called up, the process value display (red) shows «1999» flashing.</p>		<p>Overrange or underrange on analog input 2. The external setpoint is not being measured. Controller initiates lockout ⇒ Section 5.3 «Safety shutdown»</p> <p>* Check the electrical connections for open-circuit of sensors</p>
 <p style="text-align: right; font-size: small;">7865p07/0200</p>	<p>Actual value display (red) shows «XXXXXX». Setpoint display (green) shows «1999» flashing.</p>		<p>Overrange or underrange on analog input 2. The setpoint shift is not being measured. Controller initiates lockout ⇒ Section 5.3 «Safety shutdown»</p> <p>* Check the electrical connections for open-circuit of sensor</p>

11.1 Inputs

11.1.1 Analog input 1 (actual value)

For resistance thermometers, thermocouples or standard signals with 2nd order digital filter (configurable).

Resistance thermometers In 2-wire or 3-wire circuit:

Type	Measured value range
Pt100, Pt1000	-200...+850 °C
Ni100, Ni1000 DIN 43760	-60...+250 °C
Ni1000 from Landis & Staefa	-50...+160 °C

Line resistance: < 30 Ω

Line compensation

Not required for a 3-wire circuit.

When using a resistance thermometer in a 2-wire circuit, line compensation can only be made by means of the offset correction.

Thermocouples

Type	Measured value range
Fe-CuNi «J»	-200...+1000 °C
NiCr-Ni «K»	-200...+1372 °C
Cu-CuNi «T»	-200...+400 °C
NiCrSi-NiSi «N»	-100...+1300 °C

Cold-junction temperature: internal

Standard signals

Signal	Internal resistance R_i Voltage drop ΔU_e
DC 0...10 V	$R_i = 2 \text{ M}\Omega$
DC 0...1 V	$R_i = 2 \text{ M}\Omega$
DC 0...20 mA	$\Delta U_e = < 1 \text{ V}$
DC 4...20 mA	$\Delta U_e = < 1 \text{ V}$

Sampling time: 210 ms

11.1.2 Analog input 2 (external setpoint, setpoint shift)

Resistance measured value 0...1 kΩ standard signals without linearization.

Potentiometer

With 2-wire circuit

$R = 0...1 \text{ k}\Omega$

Standard signals

Signal	Internal resistance R_i Voltage drop ΔU_e
DC 0...10 V	$R_i = 2 \text{ M}\Omega$
DC 0...20 mA	$\Delta U_e = 1 \text{ V}$
DC 4...20 mA	$\Delta U_e = 1 \text{ V}$

Sampling time: 630 ms

11.1.3 Analog input 3 (outside temperature)

For resistance thermometers in a 2-wire circuit, with fixed filter time constants (21 h 18 min for the weather-dependent setpoint enable)

Resistance thermometer

Type	Measured value range
Pt1000	-200...+850 °C
Ni1000 DIN 43760	-60...+250 °C
Ni1000 from Landis & Staefa	-50...+160 °C

Sampling time: 6 s

11.1.4 Binary input «D1»

Potential-free contact for operating mode changeover:

- Modulating burner, when the contact is open, LED on the front is not lit
- 2-stage burner, when the contact is closed, LED on the front is lit

11.1.5 Binary input «D2»

Potential-free contact for the following functions, depending on the configuration:

- No function
- Setpoint shift
- Setpoint changeover

11.2 Outputs

4 relay outputs, 1 modulating analog output (optional) and a transducer supply are provided as standard.

11.2.1 Output 1 (release of burner)

Relay output (N.O. contact)

Contact rating:	AC 24...240 V, 2 A at p.f. (cos φ) > 0.6
Contact life:	> 2 x 10 ⁵ switching cycles at rated load
Internal contact protection:	Varistor S07K275

11.2.2 Output 2, 3 (3-position output)

2 relay outputs (N.O. contacts) with a common pole, for regulating unit open / close

Contact rating:	AC 24...240 V, 2 A at cos φ > 0.6
Contact life:	> 2 x 10 ⁵ switching cycles at rated load
Internal contact protection:	RC combination (C = 2.5 nF, R = 100 Ω)

11.2.3 Output 4 (limit comparator)

Relay output (N.O. contact)

Contact rating:	AC 24...240 V, 2 A at cos φ > 0.6
Contact life:	> 2 x 10 ⁵ switching cycles at rated load
Internal contact protection:	Varistor S07K275

11.2.4 Output 5, modulating output (option)

Continuous output, electrically isolated from the analog inputs:
 $\Delta U < AC\ 30\ V$, $\Delta U < DC\ 50\ V$

Standard signals	Load, burden
DC 0...10 V (short-circuit-proof)	Load = > 500 Ω
DC 0...20 mA	Burden = < 500 Ω
DC 4...20 mA	Burden = < 500 Ω

Accuracy: $\pm 0.25\ \%$, $\pm 50\ \text{ppm} / K$

11.2.5 Transducer supply

DC 24 V, 30 mA (short-circuit-proof)

11.2.6 Interface RS-485 (optional)

Baud rate: 9600
Protocol: MOD bus
Unit address: 1...99

Galvanic separation between supply voltage, analog inputs and outputs.

⇒ Section 4.3 «Galvanic separation»

11.3 General ratings

Weight: approx. 430 g
Data backup: EEPROM
Operating voltage: AC 100...240 V $\pm 10\ \%$, 48...63 Hz
Power consumption: approx. 5 VA
Electrical connection: at the rear, via pug-in screw terminal strips, angled at 45°
Electrical safety: to EN 60730
Case: mounting depth 130 mm
plastic body with rear panel, self-extinguishing
flammability class: UL94 V0
seal between case and control panel

11.3.1 Measured value accuracy

Resolution: > 15 bit

Measured value accuracy	Ambient temperature error
Resistance thermometer:	
≤ 0.05 %	≤ 50 ppm / K
Thermocouples:	
≤ 0.25 %	≤ 100 ppm / K
Standard signals:	
≤ 0.1 %	≤ 100 ppm / K

The values include the linearization tolerances.

11.3.2 Measured value circuit monitoring

Transducer	Probe break	Short-circuit
Resistance thermometer	X	X
Thermocouples	X	-
DC 0...10 V	-	-
DC 0...20 mA	-	-
DC 4...20 mA	X	X

- = is **not** detected

X = is detected, and «-1999» appears on the display

⇒ Chapter 10 «What to do if...»

11.3.3 Environmental conditions

Permissible ambient temperature range:

-20...+50 °C (short-time up to 60 °C)

Permissible storage temperature range:

-40...+70 °C

Climatic conditions:

Relative humidity ≤ 95 %, (non-condensing)

Degree of protection to EN 60529:

Front IP65

Rear IP20

Electromagnetic compatibility (EMC):

To NAMUR recommendation NE 21, EN 50 081 part 1, EN 50 082 part 2

12.1 Process data

Parameter	Display	Value range	Factory setting	Setting
Setpoint 1 ¹⁾	SP1	SPL-SPH	0	
Setpoint 2 (option) ¹⁾	SP2	SPL-SPH	0	
Digital setpoint shift (optional) ¹⁾	dSP	SPL-SPH	0	
Outside temperature (optional)	TA	⇒ Section 8.1 «C111 Inputs»	-	
Pre-definition of external setpoint ¹⁾	SP.E	SPL-SPH	-	

¹⁾ These parameters are affected by the setting for the decimal place.

12.2 Parameter level

Parameter	Display	Value range	Factory setting	Setting
Limit value of limit comparator ¹⁾	AL	-1999...+9999 digit	0	
Switching differential for limit comparator ¹⁾	HYS t	0...999.9 digit	1	
Proportional band ¹⁾	Pb.1	0.1...999.9 digit	10	
Derivative time	dt	0...9999 s	80	
Integral action time	rt	0...9999 s	350	
Contact spacing ¹⁾	db	0...999.9 digit	1	
Actuator running time	tt	10...3000 s	15 s	
Switch-on threshold burner / stage II ¹⁾	H Y S 1	0...-199.9 digit	-5	
Switch-off level stage II ¹⁾	H Y S 2	0... HYS3 digit	3	
Upper switch-off threshold ¹⁾	H Y S 3	0...999.9 digit	5	
Response threshold	q	0...999.9	0	
Heating curve slope	H	0...4	1	
Parallel displacement ¹⁾	P	-90...+90	0	

¹⁾ These parameters are affected by the setting for the decimal place.

12.3 Configuration level

Parameter	Display	Factory setting	Setting
Analog input 1, 2 and 3; setpoint changeover / shift	C111	9030	
Limit comparator; controller type; setpoint 1; locking	C112	0010	
Unit address; decimal place / unit, signal for out-of-range	C113	0110	
Measured value range start analog input 1 ¹⁾	SCL	0	
Measured value range analog input 1 ¹⁾	SCH	100	
Measured value range analog input 2 ¹⁾	SCL2	0	
Measured value range analog input 2 ¹⁾	SCH2	100	
Lower setpoint limit ¹⁾	SPL	0	
Upper setpoint limit ¹⁾	SPH	100	
Actual value correction, analog input 1 ¹⁾	OFF1	0	
Actual value correction, analog input 2 ¹⁾	OFF2	0	
Actual value correction, analog input 3 ¹⁾	OFF3	0	
Filter time constant for digital filter, analog input 1	dF1	1	

¹⁾ These parameters are affected by the setting for the decimal place.



Siemens Building Technologies AG
 Landis & Staefa Division
 Berliner Ring 23
 D - 76347 Rastatt
 Tel. 0049 - 7222 - 598 - 0
 Fax. 0049 - 7222 - 53182