



DOUGLAS BATTERY
Connect with a leader.

**LEGACY and
LEGACY GOLD
DL/DLG SERIES**

**Ferroresonant
Industrial Battery Charger**

Installation and Operating Instructions

**DOUGLAS BATTERY MANUFACTURING COMPANY
500 BATTERY DRIVE
WINSTON-SALEM, NORTH CAROLINA 27107**

FM1219 REV F, 1/07

TABLE OF CONTENTS

<u>PAGE</u>			
2	SECTION	1:	SAFETY INSTRUCTIONS
3	SECTION	2:	RECEIPT AND INSPECTION OF THE CHARGER
3	SECTION	3:	DESCRIPTION OF OPERATION
3	SECTION	4:	CONTROL FEATURES
6	SECTION	5:	INSTALLATION
7	SECTION	6:	OPERATING PROCEDURE
11	SECTION	7:	CHARGER CABINETS
12	SECTION	8:	MAINTENANCE (Input Voltage Changeover)
18	SECTION	9:	TROUBLESHOOTING GUIDE
21	SECTION	10:	SCHEMATIC DIAGRAMS

IMPORTANT SAFETY INSTRUCTIONS
INSTRUCTIONS IMPORTANTES CONCERNANT LA SECURITE

1. SAVE THESE INSTRUCTIONS. THIS MANUAL CONTAINS IMPORTANT SAFETY AND OPERATING INSTRUCTIONS.

CONSERVER CES INSTRUCTIONS. CE MANUEL CONTIENT DES INSTRUCTIONS IMPORTANTES CONCERNANT LA SECURITE ET LE FONCTIONNEMENT.

2. WORKING IN THE VICINITY OF A LEAD-ACID BATTERY IS DANGEROUS. BATTERIES GENERATE EXPLOSIVE GASSES DURING NORMAL BATTERY OPERATION. FOR THIS REASON IT IS OF THE UTMOST IMPORTANCE THAT EACH TIME BEFORE USING YOUR CHARGER, YOU READ AND FOLLOW THE INSTRUCTIONS PROVIDED EXACTLY.

IL EST DANGEREUX DE TRAVAILLER A PROXIMITE D'UNE BATTERIE AU PLOMB. LES BATTERIES PRODUISENT DES GAS EXPLOSIFS EN SERVICE NORMAL. AUSSI EST-IL IMPORTANT DE TOUJOURS RELIRE LES INSTRUCTIONS AVANT D'UTILISER LE CHARGEUR ET DE LES SUIVRE A LA LETTRE.

3. TO REDUCE RISK OF BATTERY EXPLOSION, FOLLOW THESE INSTRUCTIONS AND THOSE ON THE BATTERY.

POUR REDUIRE LE RISQUE D'EXPLOSION, LIRE CES INSTRUCTIONS ET CELLES QUI FIGURENT SUR LA BATTERIE.

4. NEVER SMOKE OR ALLOW AN OPEN SPARK OR FLAME IN THE VICINITY OF THE BATTERY OR ENGINE.

NE JAMAIS FUMER PRES DE LA BATTERIE OU DU MOTEUR ET EVITER TOUTE ETINCELLE OU FLAMME NUE A PROXIMITE DE CES DERNIERS.

5. USE CHARGER FOR CHARGING A LEAD-ACID BATTERY ONLY. IT IS NOT INTENDED TO SUPPLY POWER TO AN EXTRA LOW-VOLTAGE ELECTRICAL SYSTEM OR TO CHARGE DRY-CELL BATTERIES. CHARGING DRY-CELL BATTERIES MAY CAUSE THEM TO BURST AND CAUSE INJURY TO PERSONS AND DAMAGE TO PROPERTY.

UTILISER LE CHARGEUR POUR CHARGER UNE BATTERIE AU PLOMB UNIQUEMENT. CE CHARGEUR N'EST PAS CONCU POUR ALIMENTER UN RESEAU ELECTRIQUE TRES BASSE TENSION NI POUR CHARGER DES PILES SECHES. LE FAIT D'UTILISER LE CHARGEUR POUR CHARGER DES PILES SECHES POURRAIT ENTRAINER L'ECLATEMENT DES PILES ET CAUSER DES BLESSURES OU DES COMMAGES.

6. NEVER CHARGE A FROZEN BATTERY.

NE JAMAIS CHARGER UNE BATTERIE GELEE.

7. DO NOT OPERATE CHARGER IN A CLOSED-IN AREA OR RESTRICT VENTILATION IN ANY WAY.

NE PAS FAIRE FONCTIONNER LE CHARGEUR DANS UN ESPACE CLOS ET/OU NE PAS GENERER LA VENTILATION.

8. DANGER: RISK OF ELECTRICAL SHOCK. DO NOT TOUCH UNINSULATED PORTION OF OUTPUT CONNECTOR OR UNINSULATED BATTERY TERMINAL.

DANGER: RISQUE DE CHOCS ELECTRIQUES. NE PAS TOUCHER LES PARTIES NON ISOLEES DU CONNECTEUR DE SORTIE OU LES BORNES NON ISOLEES DE L'ACCUMULATEUR.

9. CAUTION: DISCONNECT SUPPLY BEFORE CHANGING FUSE OR SERVICING CHARGER.

ATTENTION: COUPER L'ALIMENTATION AVANT DE REMPLACER LES FUSIBLES.

SECTION 2RECEIPT AND INSPECTION

Upon receipt of the Battery Charger the information on the shipping carton should be checked against your order. Any discrepancies should be reported to the nearest authorized representative.

Whenever possible, move the charger to the installation site before uncrating. All chargers can be handled with a lift truck by inserting the forks under the bottom of the charger.

Remove the carton and inspect the charger for damage. If there is any damage, save the carton for inspection and notify the carrier immediately.

Check the nameplate & labels against your order & specifications. Any discrepancies should be reported immediately to the nearest authorized representative.

SECTION 3DESCRIPTION OF OPERATION

LEGACY AND LEGACY GOLD Industrial Battery Chargers are full wave, silicon rectified, ferroresonant chargers.

Charging current is regulated by the ferroresonant transformer(s). The transformers allow the battery to determine its own charge rate with respect to its state of discharge.

A solid state, pre-programmed microcomputer provides total control of charge termination, preventing both undercharging and overcharging. The microcomputer incorporates built in fault detection to ensure correct battery connection and smooth operation. The charge is terminated automatically when the control determines that the battery is fully charged based on $dv/dt - di/dt$.

SECTION 4CONTROL FEATURES

4.1) Automatic five-second delayed start upon connection of a proper sized, good battery.

4.2) Battery voltage sensing determines if there is a proper sized battery connected to the charger. This prevents charging if there is a bad battery, no battery connected, bad battery to charger connection or battery voltage and charger mismatch.

4.3) Battery voltage and current are continuously monitored and controlled.

4.4) Automatic $dv/dt-di/dt$ charge termination. (Voltage slope detection is current compensated.)

4.5) Negative battery slope termination to prevent overcharge/thermal runaway.

4.6) Automatic 12-hour "REFRESH" charge adds a top off charge to a fully charged battery. The charger will start a "refresh" charge 12 hours after a normal charge complete has been reached, assuming that the battery was not disconnected during that time. The charger will automatically start charging the battery and will charge until $dv/dt-di/dt$ is reached. (DLG only - Automatic REFRESH may be disabled by removing R35 from the control board assembly)

4.7) Automatic Shutdown Lockout will not allow a charge to start after a manual or problem shutdown occurs. Automatic Shutdown Lockout is cleared after the "Shutdown" battery is disconnected. This allows a charge to begin upon connection of a good, proper sized battery.

4.8) Manual STOP switch - Will stop the charger from charging. The display will indicate "OFF" until the battery is disconnected. When pressed with no battery connected, displays the delay start setting. When pressed during watering mode (LEGACY GOLD only), will terminate watering but allow refreshes if battery remains connected.

4.9) One to nine hours programmable delayed start thumbwheel switch. This rotary switch can be set from 0 to 9 hours to delay the start of charge.

4.10) Optional Automatic Equalization cycle every 5th cycle. This option can be enabled by DIPswitch (DLG) or removal of W1 (DL). For a charge cycle to be counted, the battery must be on charge at less than 80% for 1 hour or more from start of charge.

4.11) Equalize switch (LEGACY GOLD ONLY)- The switch when depressed will turn on and off the three-hour additional manual equalizing charge. When the equalize function is turned on, an "E" will be displayed in the left most digit of the display. The "E" will flash during the actual equalize charge cycle (manual and automatic). If auto-equalize has been selected, pressing this switch prior to connecting the battery will allow the number of charge cycles before auto-equalize cycle to be displayed.

4.12) Automatic shutdown occurs for any of five failure conditions. The SHUTDOWN LED will be flashing.

- a) **Fault code "Lo U"** - Low volts per cell - the battery voltage is less than 1.7 vpc. The charger will not be "locked off". The charger will automatically start charging when the battery voltage is greater than 1.7 vpc.
- b) **Fault code "HI U"**-High volts per cell - the battery voltage is greater than 2.8 vpc.
- c) **Fault code "dISC"** - Battery disconnected from charger during charge
- d) **Fault code "dur"** - Charge time duration exceeded - backup timer expired during "high rate" charge
- e) **Fault code "Lo I"**- Low charging current - charging current less than approximately 3 amps.

4.13) LED Indicators

1. "CHARGING" - charger is charging the battery
2. "80%" - the battery voltage is greater than 2.37 vpc.
3. "CHARGE COMPLETE" - the charge cycle has been terminated normally.
 -If flashing (1/2 second on every 4 sec.), the charger is set to equalize at the end of the charge cycle. See section 6.7.
 -If flashing on and off each second with the CHARGING and 80% LED's lit continuously then the charger is in the refresh mode.
4. "SHUTDOWN" - the unit has shut down for a fault; see section 4.12.

4.14) LED TEST button- All LED's and display segments will illuminate when this button is pressed.

4.15) Display mode switch:(LEGACY GOLD ONLY)

1. Press once to display AMP-HRS RETURNED
2. Press twice to display TOTAL CHARGE TIME
3. Press three times to display average BATTERY VOLTAGE/CELL The display will show the above function for approximately 10 seconds and then return to display charge current or the sequencing dash.

4.16) DIGITAL DISPLAY Readout will display the following information:

1. Charging current
2. Fault codes
3. Delay start time
4. Equalize mode
5. Amp-Hours returned for this charge cycle. (LEGACY GOLD ONLY)
6. Charging time - the length of time the charger was charging. (LEGACY GOLD ONLY)
7. Volts per Cell - the average battery cell voltage. (LEGACY GOLD ONLY)
8. Cool-down time - the amount of time since the charger stopped charging. (LEGACY GOLD ONLY)
9. Watering cycle (LEGACY GOLD ONLY)

4.17) A Watering Signal is provided at connector pin P3-3 (LEGACY GOLD ONLY) This low current signal is normally logic level 'lo' and goes 'hi' at End of every Charge cycle (watering mode). When in the watering mode the signal pulses on for 15 sec. and off for 15 sec. for a total of 20 repetitions OR on continuously for 5 min (DIP Sw. selectable). To prevent over-watering, this signal will not occur if the charge reaches 80% in less than 5 min. from start of charging. This signal is meant to interface with an external circuit for operating a watering valve. During watering the display shows 'H2O'.

Without a battery connected, pressing the Equalize Switch will display the number of cycles remaining before the next auto-equalize. If Equalize Charge is selected, watering occurs immediately after the Equalize cycle.

SECTION 5INSTALLATION5.1) PHYSICAL LOCATION:

Charging areas should be clean and dry. The temperature of the charging room should be between 32°F (0°C) and 77°F (25°C), with occasional and brief periods of ambient temperature as high as 104°F (40°C). Combustible materials, open flames and smoking should not be permitted near or in the charging area.

***** WARNING *****
 A BATTERY ON CHARGE WILL EMIT EXPLOSIVE GAS. VENTILATE THE CHARGING AREA
 TO PREVENT GAS ACCUMULATION.

5.2) MOUNTING:

The LEGACY AND LEGACY GOLD charger cabinets must be mounted on a surface constructed from non-combustible material, such as stone, brick, concrete or metal. Mounting holes are provided in the frame for securing the charger. Most chargers can be stacked up to three high. Contact the nearest authorized representative for specific instructions, if stacking is necessary.

5.3) INPUT POWER CONNECTION:

THE LEGACY and LEGACY GOLD chargers are shipped from the factory connected for the input voltage specified on your purchase order. A "STOP" label, located inside the door, indicates the factory set input voltage.

If the charger is to be used at a different AC voltage than is presently set for, the charger may be adjusted to operate for the different AC service. Refer to SECTION 8.2.1 CHANGING THE AC INPUT LINE VOLTAGE.

***** WARNING *****
 VERIFY THE AC ELECTRICAL SERVICE IS DISCONNECTED AT THE SOURCE BEFORE
 ATTEMPTING TO CONNECT AC POWER TO THE CHARGER.

The AC input terminals are identified by a red on white AC INPUT sticker located on the base near the fuse block. The AC input cable is to be connected to the proper AC INPUT terminals within the charger cabinet.

The fuse block's input terminals are rated for 14 awg to 2 awg wire. The recommended torque is listed on the fuse block itself. The ground lug is rated for 14 awg to 6 awg wire with a recommended torque of 12 in lbs.

A bare wire, green or green with yellow stripe grounding wire is to be connected from the Grounding Terminal within the charger cabinet to the system ground. The Grounding Terminal is identified by a green on white Ground Terminal Label on the charger base. If a system ground is not available, the charger frame must be connected to a driven ground rod in accordance with National and Local electrical codes. Proper application and tight terminal connections are important in avoiding future problems.

5.4) OUTPUT POWER CONNECTION:

The charger is normally furnished with an output charge plug or receptacle. Verify that the connectors on both the battery and the charger are correct. Verify that when connected, the positive polarity (red) of the charger is connected to the positive terminal of the battery.

5.5) DIP SWITCH Settings (LEGACY GOLD ONLY):

The switch is located on the component side of the control board. The factory default setting is all switches in the ON position except for units designed for 50 Hz applications.

<u>SWITCH NUMBER</u>	<u>ON</u>	<u>OFF</u>
1.	Single di/dt compensation	Double di/dt compensation
2.	Normal dv/dt termination	Triple dv/dt termination
3.	60 Hz operation	50 Hz operation
4.	Display cool-down time	Do not display cool-down time
5.	Auto-Equalize Disabled	Auto-equalize enabled
6.	Normal current display	Double current display
7.	Water signal is pulsed	Water signal is continuous
8.	80% point - 2.37 vpc	80% point - 2.45 vpc

SECTION 6OPERATING PROCEDURE6.1) PRELIMINARY SETUP:

With all power removed from the charger set the DIPswitches per the previous tables before attempting to charge a battery.

Once power has been applied to the charger, a "dash" will sequence across the display on the front panel. This indicates the charger is in the "IDLE MODE", awaiting a battery connection.

6.2) IMMEDIATE/DELAY START:

The control may be programmed to delay the start of the charge from one to nine hours as well as an immediate start (5 second delay) of the charge upon battery to charger connection. Note: all units are shipped from the factory set for immediate start (0-hour delay).

If a power failure occurs, no damage will occur to the battery or the charger. If a battery is still connected when power returns, the LEGACY AND LEGACY GOLD will override any delayed start setting and initialize an immediate start of the charge. Once the charge has been terminated, the delay start will function normally thereafter.

6.2.1) Remove AC power from the charger.

6.2.2) Open the charger cabinet door.

6.2.3) Locate the DELAY START thumbwheel switch behind the front panel at the bottom of the control board. Adjust the DELAY START thumbwheel switch until the NUMBER INDICATOR on the switch yields the number of delay hours desired.

6.2.4) Close and secure the cabinet door.

6.2.5) Apply AC power to the LEGACY AND LEGACY GOLD SERIES charger.

6.2.6) Without a battery connected the setting may be checked by pressing and holding the stop button. When a good, proper sized battery is connected to the LEGACY AND LEGACY GOLD SERIES charger, the display will indicate the amount of time before the charge is initiated and the control will begin a countdown to charge.

6.3) CHARGING THE BATTERY:

Compare the number of cells and amp-hour capacity of the battery to be charged with the charger rating found on the charger nameplate. The number of cells in the battery to be charged MUST match the nameplate data. The amp-hour ratings should also match for timely charging of the battery. Once the battery to be charged has been determined to match the charger, then connect the battery to the charger. The control will measure the average volts/cell of the connected battery.

6.3.1) If the control has verified the connection of a good battery (between 1.7 and 2.8 volts/cell), the display will show a countdown to charge initialization and the LED's will be flashing. When the countdown reaches zero, the control will start the charging operation.

6.3.2) If the average volts/cell reading is less than 1.7 volts, the display shows "Lo U", the charge will not begin and the red SHUTDOWN LED will be flashing. If the battery voltage "floats" above 1.7 vpc the charger will automatically begin a normal charge cycle.

6.3.3) If the average volts/cell is greater than 2.8 volts, the display shows "HI U", the red SHUTDOWN LED will turn on. Again, the charge will not begin.

6.3.4) Once the charge begins, the display will count down from 9 to 0 then show the output charging current in amperes. The green CHARGING LED will be on.

6.4) TERMINATION OF CHARGE:

There are three ways in which the charge may be terminated. They are: CHARGE COMPLETED TERMINATION via $dv/dt - di/dt$ slope, MANUAL TERMINATION, and PROBLEM SHUTDOWN TERMINATION.

6.4.1) CHARGE COMPLETED TERMINATION occurs when a battery reaches full charge. The LEGACY AND LEGACY GOLD control monitors the battery charge characteristics. The control utilizes di/dt current compensation to obtain an accurate battery voltage charging slope, dv/dt measurement. Once the control has verified that the battery charge slope has reached the predetermined value for full charge, the charge is terminated automatically. Once the charge is completed and terminated, the CHARGE COMPLETED LED will turn on, and the display will be in the IDLE MODE. The controller will display the battery cool-down time on the LEGACY GOLD units only.

6.4.2) MANUAL TERMINATION, while charging, is accomplished by pressing the STOP push-button switch located on the front panel.

To remove a charging battery from the charger, it is important to press the STOP push-button switch first before disconnecting the battery from the charger. Failure to do this may damage the charger.

When the charge has been terminated due to MANUAL TERMINATION, the red SHUTDOWN LED will be on continuously (until the battery is removed). The display will show "OFF".

6.4.3) PROBLEM SHUTDOWN

Each of the PROBLEM SHUTDOWN terminations are indicated by a flashing red SHUTDOWN LED and a FAULT code (section 4.12). After the battery is removed, the red SHUTDOWN LED will remain flashing for one hour. The display indicator will remain on until the battery is disconnected from the LEGACY AND LEGACY GOLD SERIES charger.

6.5) REFRESH CHARGE:

When a battery remains connected to the charger for 12 hours after the charge has been completed, the control will restart another charge cycle. The charge rate of the battery will be monitored with dv/dt-di/dt termination occurring typically within 35 minutes. When the charger is in REFRESH mode, the charge amps will be displayed, the CHARGING LED and 80% CHARGE LED will be on, and the CHARGE COMPLETE LED will be blinking.

A two-day weekend will have from three to five REFRESH cycles.

Automatic REFRESH may be disabled by removing R35 from the control board assembly.

6.6) LED TEST: (LEGACY GOLD ONLY)

The LED TEST button may be pushed to illuminate all LED's and display segments, to ensure that all are functional.

6.7) THREE-HOUR EQUALIZE CYCLE:

6.7.1) A 3-hour AUTOMATIC EQUALIZATION cycle will occur every 5th charging cycle when this feature is enabled. A cycle is counted only if 1 hour or more time is required to reach 80% charged from charge start. To enable, set DIP Sw 5 to OFF (DLG) or remove W1 (DL).

6.7.2) The manual Equalize button when pushed will provide a timed three-hour charge extension after dv/dt-di/dt termination has been reached. It will not reset the automatic equalize counter, if Auto-Equalize is enabled.

6.8) PROBLEM SHUTDOWN:

Each of the PROBLEM SHUTDOWN terminations are indicated by a flashing red SHUTDOWN LED and a FAULT code (section 4.12). After the battery is removed, the red SHUTDOWN LED will remain flashing. The fault code will remain until the battery is disconnected from the charger.

SECTION 7 CHARGER CABINETS

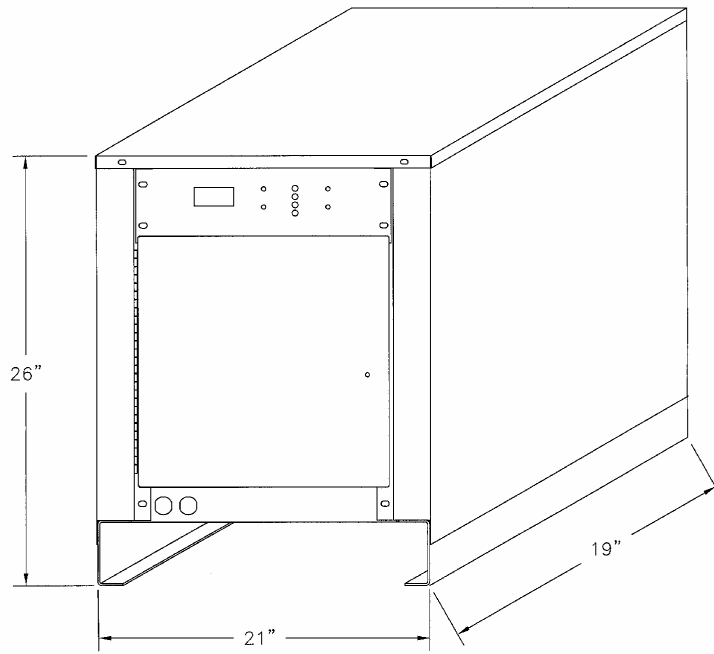

SINGLE PHASE

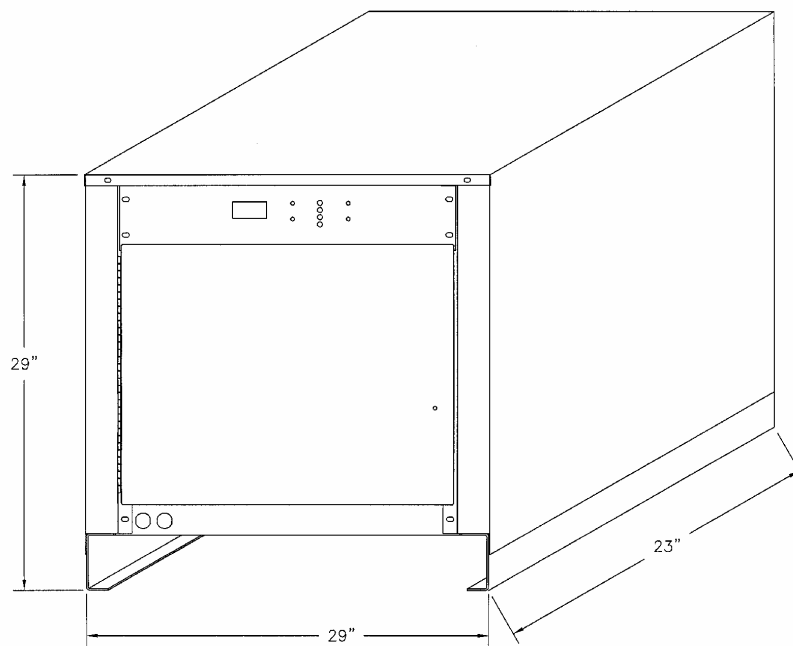

THREE PHASE

SECTION 8
MAINTENANCE

***** IMPORTANT *****

BEFORE PERFORMING ANY MAINTENANCE ON THE CHARGER:

- A) If a battery is being charged, terminate the charge by pressing the STOP button.
- B) Disconnect the battery from the charger.
- C) Remove AC power from the charger.
- D) Lock and tag unit out of service.

***** WARNING *****

HIGH VOLTAGES EXIST WITHIN THE CHARGER WHICH CAN CAUSE SEVERE INJURY OR DEATH. SERVICE SHOULD BE PERFORMED ONLY BY QUALIFIED SERVICE PERSONNEL. IMPROPER SERVICING MAY DAMAGE THE CHARGER.

8.1) MONTHLY PREVENTIVE MAINTENANCE:

8.1.1) If a battery is being charged, terminate the charge by pressing the STOP button.

8.1.2) Disconnect the battery from the charger.

8.1.3) Remove AC power from the charger.

8.1.4) Using compressed air, remove any dust from the inner cabinet walls and internal components of the charger.

8.1.5) Wipe the exterior of the cabinet and clear any obstructions from the ventilation louvers.

8.1.6) Make sure that all bolted or screwed electrical connections are tight.

8.1.7) Make sure that the insulation on all cables and wires is in good condition. Replace if necessary.

8.2) CHARGER ADJUSTMENTS:

8.2.1) CHANGING THE AC INPUT LINE VOLTAGE:

LEGACY AND LEGACY GOLD chargers are designed to operate at different voltage levels. Single-phase chargers may be ordered for 120/240 volts, 208/240/480 volts or 240/480/575 60 Hz electric services depending on the charger. Three phase chargers may be ordered for 208/240/480, 240/480/575 volts 60 Hz electric services only. They may also be ordered set for 220/380/440 or 240/415 50 Hz.

If the charger is to be operated on a different rated input voltage than the ordered value, follow the voltage changeover instructions described in section 8.2.2.

NOTE: THREE PHASE UNITS WILL CONTAIN EITHER TWO OR THREE TRANSFORMERS. BE SURE TO MATCH THE CORRECT SCHEMATIC WITH THE TRANSFORMER CONFIGURATION OF YOUR PARTICULAR UNIT.

8.2.2) VOLTAGE CHANGEOVER INSTRUCTIONS:

- 1) Manually terminate the charging battery by pressing the STOP button and disconnect battery from charger, if charger was in charge mode.
- 2) Remove AC power from the charger.
- 3) Locate the Terminal Block(s) with Jumpers (one Terminal Block per phase) and the label describing the various voltage/jumper configurations. (Refer to FIGURES 8A-8F). The Terminal Block(s) with Jumpers are located on the Ferroresonant Transformer(s).
- 4) Change the jumpers in accordance with the Jumper label, located within the charger cabinet, for the voltage input configuration desired.
- 5) Locate the AC fuses and fuse label. Change the fuses to the appropriate value as indicated by the punched or circled holes on the fuse label.
- 6) Locate the Control transformer. Change the primary input connection in accordance with the voltage printed on the transformer (Refer to FIGURE 8J).
- 7) Change the voltage level on the STOP label to the new voltage level.
- 8) CHECKLIST:
 - a) Verify the Terminal Block(s) with Jumpers is configured correctly. Make sure that all Terminal Blocks with Jumpers have been changed properly, and connections are tight.
 - b) Verify the installation of properly rated fuses.
 - c) Verify that the Control Transformer primary taps have been changed correctly.
 - d) Verify the STOP label, located inside the door, has been corrected to the new input voltage level that the charger is set for.
- 9) Close and secure the cabinet.
- 10) Remove the lock and tag.
- 11) Reapply AC power to the charger.

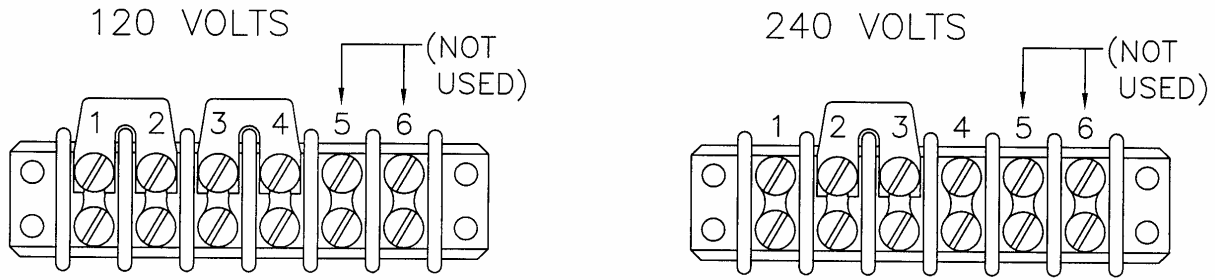

FIGURE 8A AC VOLTAGE SELECTOR BLOCKS
120 / 240 VAC SINGLE PHASE MODELS ONLY

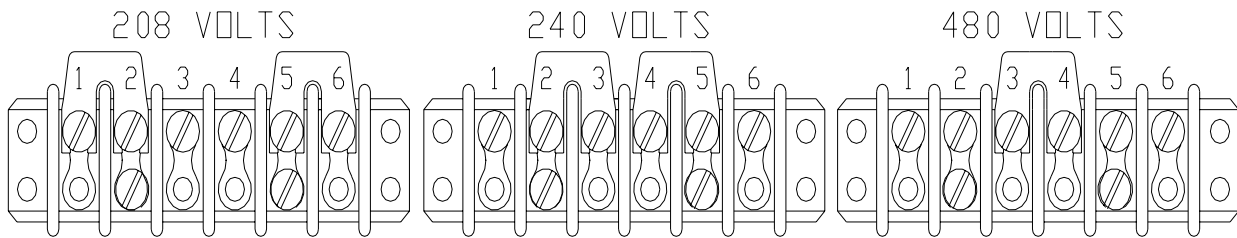

FIGURE 8B AC VOLTAGE SELECTOR BLOCKS

208/240/480 VAC SINGLE PHASE AND 3 TRANSFORMER THREE PHASE MODELS ONLY

NOTE: FOR 3 PHASE ALL THREE BLOCKS MUST BE SET IDENTICALLY

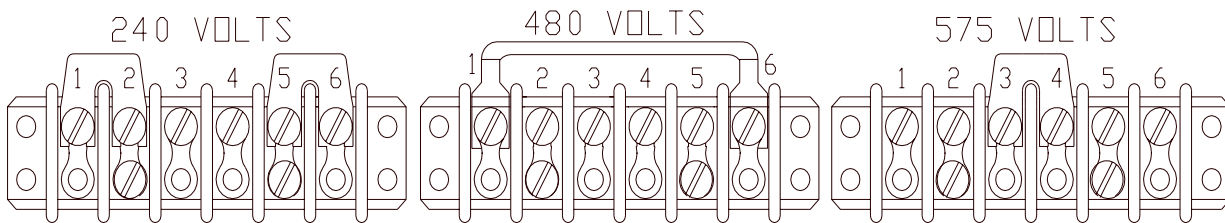

FIGURE 8C AC VOLTAGE SELECTOR BLOCKS

240/480/575 VAC SINGLE PHASE AND 3 TRANSFORMER THREE PHASE MODELS ONLY

NOTE: FOR 3 PHASE ALL THREE BLOCKS MUST BE SET IDENTICALLY

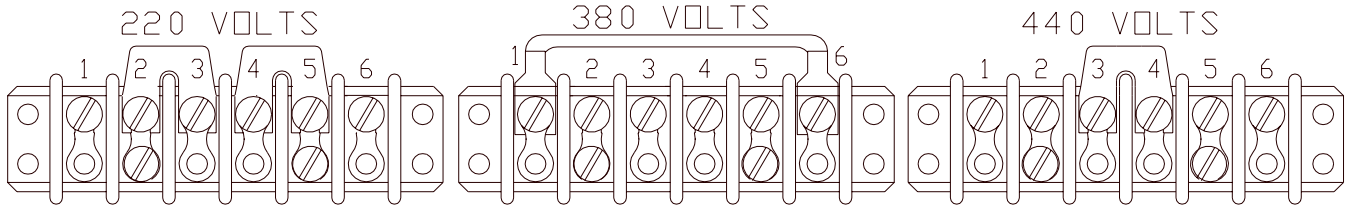

FIGURE 8D AC VOLTAGE SELECTOR BLOCKS

220/380/440 VAC SINGLE PHASE AND 3 TRANSFORMER THREE PHASE MODELS ONLY

NOTE: FOR 3 PHASE ALL THREE BLOCKS MUST BE SET IDENTICALLY

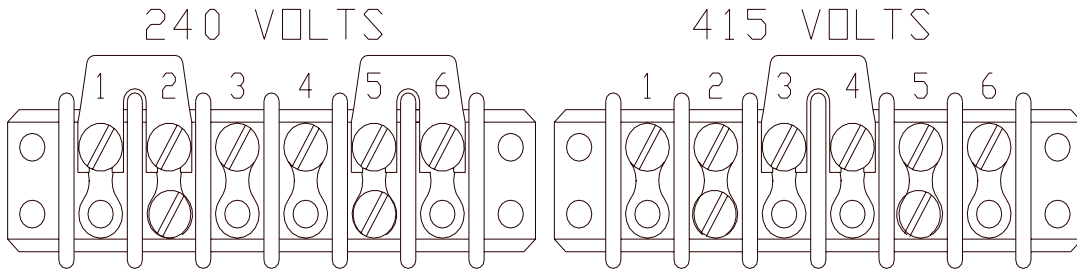

FIGURE 8E AC VOLTAGE SELECTOR BLOCKS

240/415 VAC SINGLE PHASE MODELS ONLY

415 VOLTS

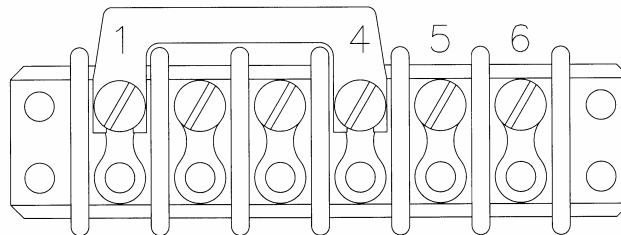

FIGURE 8F AC VOLTAGE SELECTOR BLOCKS

415 VAC 3 TRANSFORMER THREE PHASE

NOTE: FOR 3 PHASE ALL THREE BLOCKS MUST BE SET IDENTICALLY

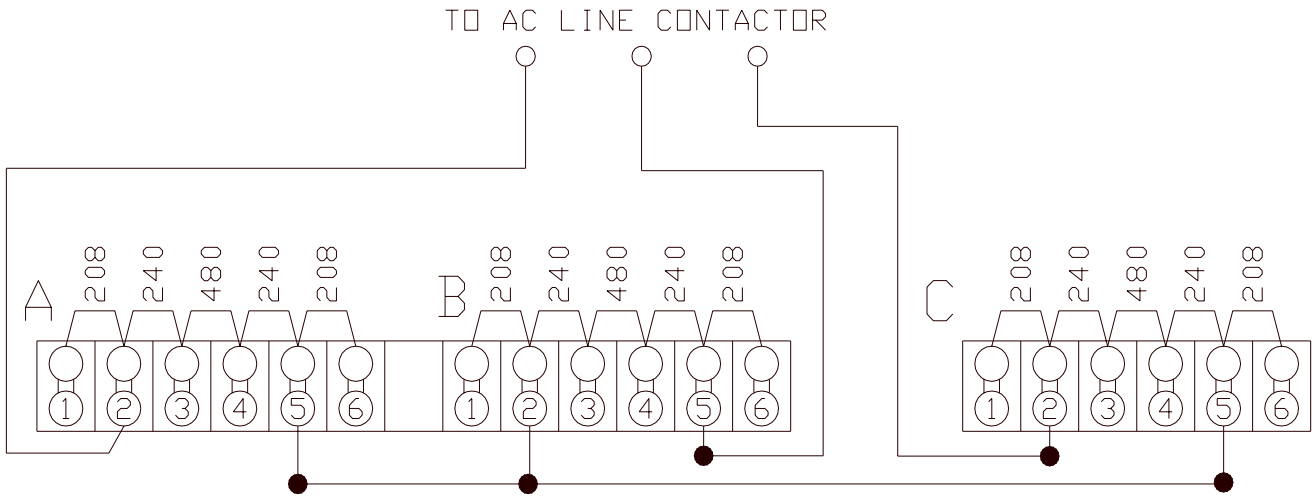

FIGURE 8G AC VOLTAGE SELECTOR BLOCKS
208/240/480 VAC THREE PHASE 2 TRANSFORMER MODELS ONLY

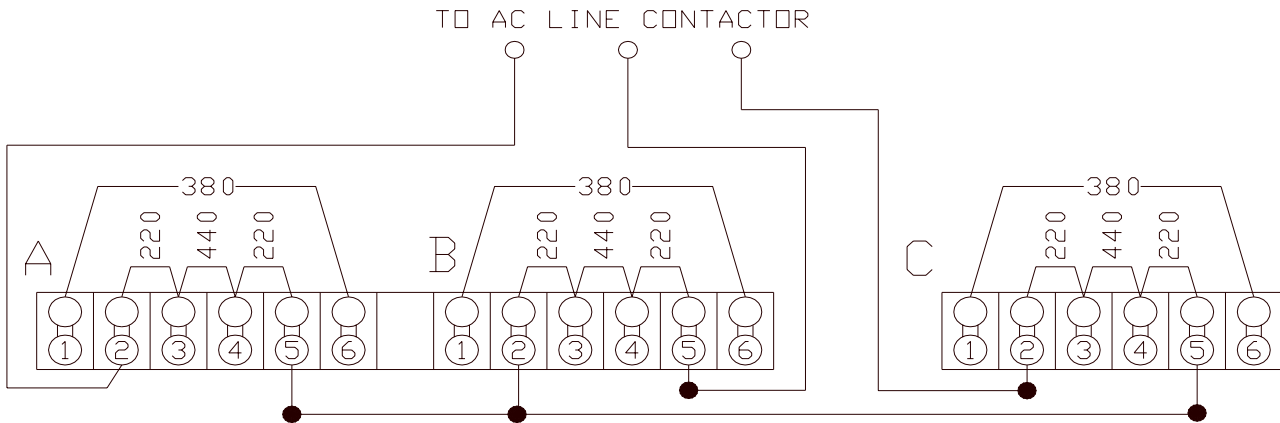

FIGURE 8H AC VOLTAGE SELECTOR BLOCKS
220/380/440 VAC THREE PHASE 2 TRANSFORMER MODELS ONLY

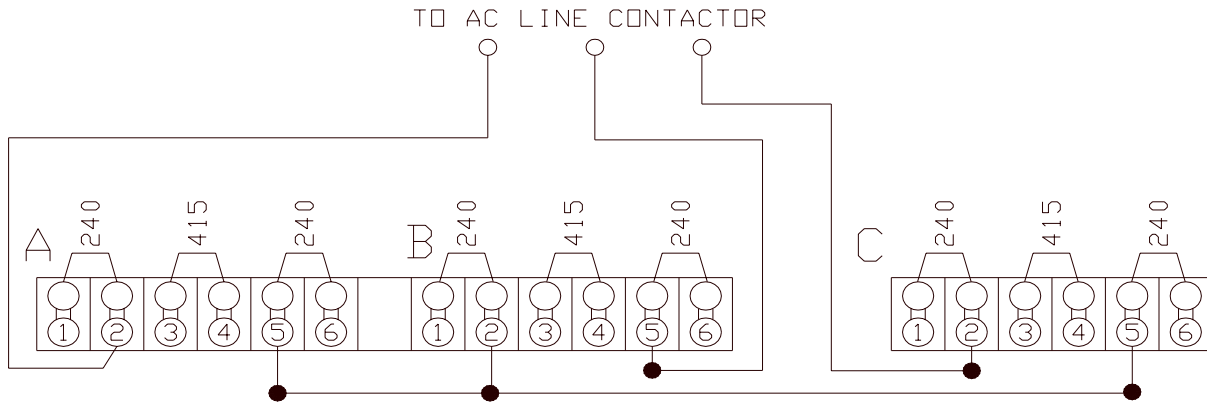

FIGURE 8I AC VOLTAGE SELECTOR BLOCKS
240/415 VAC THREE PHASE 2 TRANSFORMER MODELS ONLY

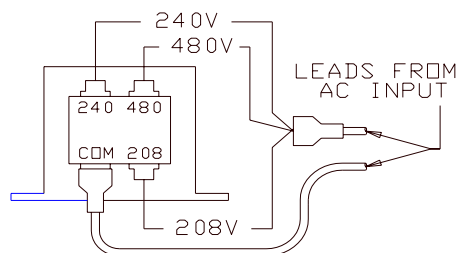

FIGURE 8J VOLTAGE SELECTION ON PRIMARY
SIDE OF CONTROL TRANSFORMER

**NOTE: OTHER MODELS ARE SIMILAR IN CONFIGURATION

8.2.3) CHARGING CURRENT START & FINISH RATE ADJUSTMENT:

***** WARNING *****
HIGH VOLTAGES EXIST WITHIN THE CHARGER, WHICH CAN CAUSE SEVERE INJURY OR DEATH. SERVICE SHOULD ONLY BE PERFORMED BY QUALIFIED SERVICE PERSONNEL. IMPROPER SERVICING MAY DAMAGE THE CHARGER.

Each of the Ferroresonant Transformers has multiple taps for the Resonant Capacitor. These allow the charger output current to be adjusted to accommodate variations in the AC line voltage.

Figure 8K is a schematic representation of the Ferroresonant Transformer Resonant Winding Taps and the Resonant Capacitor. There are six Resonant Winding Taps numbered 7 through 12. By connecting the Resonant Capacitor to taps 7 and 12, the charger will be set for maximum output current. The Resonant Winding can then be reduced in 5% increments down to a maximum reduction of 30%.

Each Ferroresonant Transformer is factory set for a nominal charging current start rate of (18% for LEGACY GOLD and 15% for legacy models) and a finish rate of 5% of the charger's maximum amp-hour output rating. If it is necessary to change the battery charger's start and finish rate current, use the following procedure.

CAUTION

OBTAIN POSITIVE PROOF THAT THE CHARGER IS GIVING UNSATISFACTORY PERFORMANCE BEFORE ATTEMPTING ANY ADJUSTMENT. THE MEASURING EQUIPMENT USED FOR FACTORY ADJUSTMENT IS EXTREMELY ACCURATE. FACTORY TEST CONDITIONS ALLOW FOR AN ADJUSTMENT WHICH IS OPTIMAL FOR A GIVEN RATING. RECHECK ALL SYMPTOMS BEFORE PROCEEDING.

- 1) Manually terminate the charging battery by pressing the STOP button. Disconnect the battery from the charger.
- 2) Remove AC power from the charger.
- 3) Locate Resonant Winding Taps 7 through 12 on each of the Ferroresonant Transformers. Note which taps are connected to the Resonant Capacitor.
- 4) Use FIGURE 8K to determine which of the taps are to be connected for an increase or decrease in the charging current rate. Adjustments should be made in 5% increments.

- 5) Verify the proper connection of each Ferroresonant Transformer to its respective Capacitor. Each Ferroresonant Transformer should be tapped the same for proper operation.
- 6) Close and secure the charger cabinet.
- 7) Connect the AC input line to the AC source.

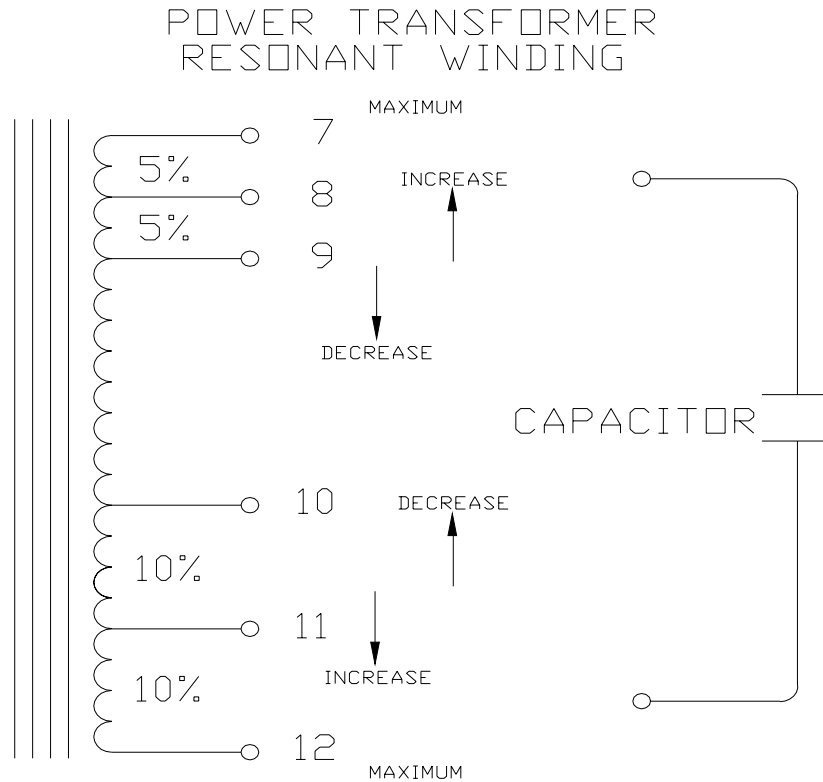

FIGURE 8K
FERRORESONANT TRANSFORMER CAPACITOR WINDING

SECTION 9
TROUBLESHOOTING GUIDE

9.1) SYMPTOM - POWER IS APPLIED BUT THE DISPLAY IS NOT ON!

1) AC POWER CONNECTION:

Make sure the AC input line, located at the AC FUSE BLOCK, is connected to the AC power outlet. Measure the voltage and verify that AC power is at the charger.

2) CONTROL TRANSFORMER:

Locate the Control Transformer. Measure the AC input voltage at the Control Transformer primary. If there is no voltage measured, repair open circuit.

Measure the Control Transformer secondary voltage across terminals 5&7. The AC voltage should be approximately (18 to 20) volts rms. If no voltage is measured, then the Control Transformer is defective and should be replaced. If the measured voltage is extremely high or low, verify that the AC line input is connected to the proper terminals of the Control Transformer. (Refer to SECTION 8.2.1, CHANGING THE AC INPUT LINE VOLTAGE.)

3) MAIN, CELL SELECT CONNECTIONS:

Locate the Main board and Cell Select board on the front panel. Verify the proper connection and polarity of the board and cables.

4) MAIN BOARD:

If there is the appropriate voltage level across the Control Transformer, disconnect AC power then reapply AC power. This action will reset the Micro controller. If the display is still not on, replace the main and/or cell select board.

9.2) SYMPTOM - POWER IS APPLIED; DISPLAY IS IN IDLE MODE BUT CHARGER WILL NOT START; OR CHARGE STARTS BUT IS TERMINATED IMMEDIATELY!

1) PROPER BATTERY:

Verify that the number of cells in the battery to be charged matches the charger. Also, check the Fault codes section 4.12.

2) BATTERY CONDITION:

Measure the total battery voltage. Divide the voltage value measured by the number of battery cells. This will yield an average volts per cell value. If the average volts per cell value is less than 1.5 volts or greater than 2.8 volts, then the battery is bad and should not be used.

3) AC & DC FUSES:

Disconnect the battery and AC input power from the charger. Verify that the fuses are not open. Replace any defective fuses and check the following:

- a) Make sure that the battery-to-charger cables are connected with the proper polarity.
- b) Verify that the Terminal Block with Jumpers is correctly configured for the AC input voltage currently being used. If the jumpers are not correctly configured, then go to SECTION 8.2.1 of this manual, CHANGING AC INPUT LINE VOLTAGE.
- c) Verify that AC power and battery have been disconnected from the charger. Locate the rectifier diodes on the heatsink. Remove the connecting wires from the diodes. Test the diodes and replace if faulty.
- d) Make sure all connections are tight.

4) CONTROL TRANSFORMER:

Apply AC power to the charger and measure the AC voltage across the Control Transformer secondary terminals 8 and 9. The secondary voltage should be approximately 24 volts rms. If there is no voltage measured at the secondary, the Control Transformer is defective and should be replaced. If the voltage measured is extremely high or low, verify the AC input is connected to the proper Control Transformer terminals.

9.3) SYMPTOM - CHARGE TERMINATES EARLY!

1) HIGH VOLTS/CELL: HI U

If this indicator is on, then the LEGACY or LEGACY GOLD control measured the average volts/cell to be greater than 2.8 volts per cell.

- a) Verify that the Battery connected to the charger has the correct number of cells.
- b) If the battery has the appropriate number of cells, measure the battery voltage. Divide the measured voltage value by the number of battery cells. This value is the average volts per cell of the battery. If the average volts per cell of the battery is between 1.7 and 2.8 volts/cell, then the battery is good.

2) LOW CURRENT: Lo I

If this indicator is on, the battery on charge was not receiving current.

- a) Disconnect the battery and AC input power from the charger.
- b) Check the AC and DC Fuses. Verify that the fuses are not open. Replace any faulty fuses.
- c) Verify the Magnetic Amplifier is not an open. Check for continuity between the Magnetic Amplifier and Cell Select Board. Repair any bad connections. Replace the Magnetic Amplifier if faulty.
- d) Verify the AC Resonant Capacitor is not an open. Replace the Capacitor if defective.

3) CHARGE TIME EXCEEDED: dur

This indicates that the battery did not reach 80% of full charge within nine hours or that the battery did not reach charge complete within six hours from 80%.

Disconnect the battery and AC input power from the charger. Verify that the AC and DC Fuses are not open. Replace any defective fuses.

Verify that the charger and battery AMP-HR size are matched.

4) CABLE DISCONNECTION: dISc

The CABLE DISCONNECTION indicator will be on whenever the battery cables are disconnected while the battery is charging. Always make sure to manually shutdown (press the stop button) the charge before disconnecting the cables.

5) LOW VOLTAGE: Lo U

Having a flashing red SHUTDOWN LED with "Lo U" on indicates that the control measured the average volts/cell to be less than 1.5 volts.

The LOW VOLTAGE condition does not "lock" the charger off since the charger will automatically start charging if the battery's voltage rises about 1.7 volts per cell.

Verify that the battery has the same number of cells for which the charger is rated.

If the battery has the appropriate number of cells, measure the battery voltage. Divide the measured voltage value by the number of battery cells. This value is the average volts per cell of the battery. If the average volts per cell of the battery is between 1.7 and 2.8 volts/cell, then the battery is good; if not, the battery should not be used.

SECTION 10
SCHEMATICS

See the following pages

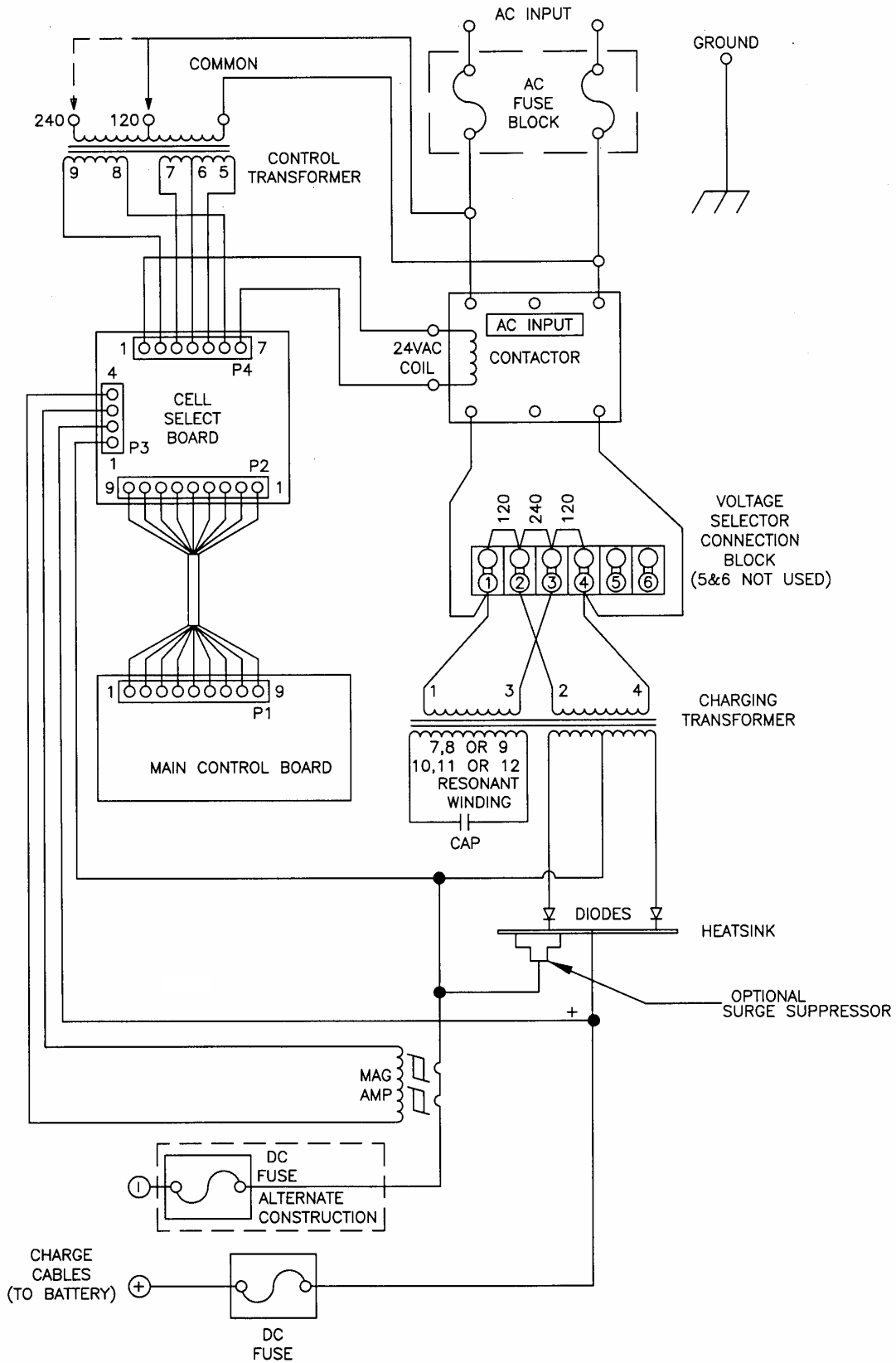

1-PHASE SCHEMATIC

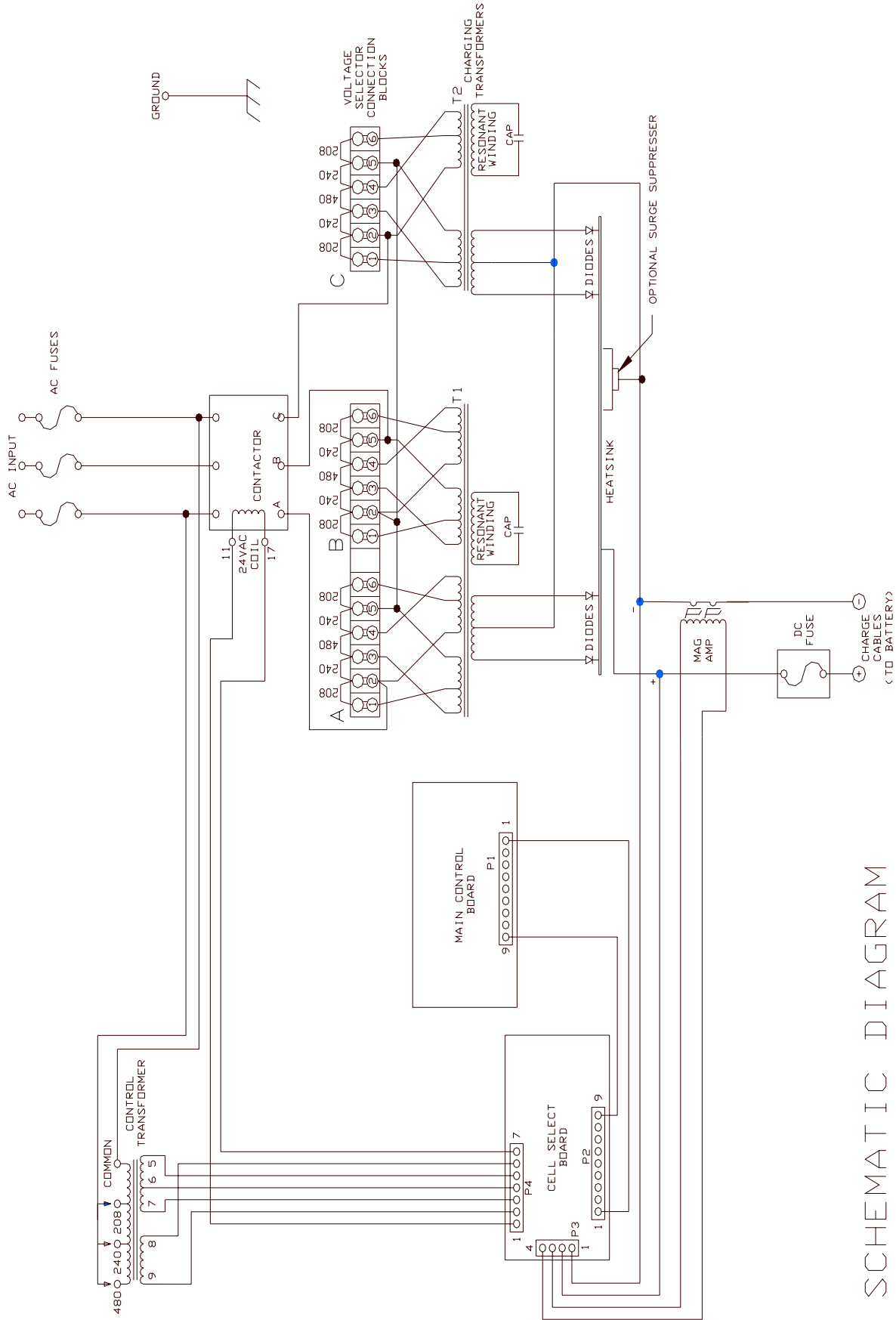

SCHEMATIC DIAGRAM

3 PHASE, 2 TRANSFORMER MODELS

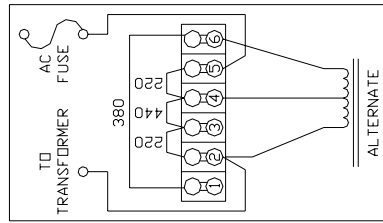
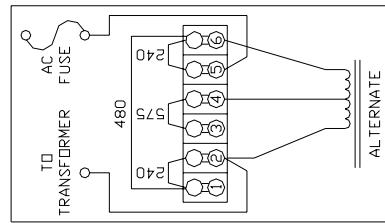
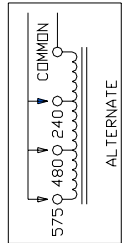
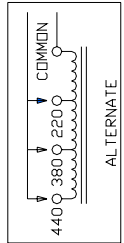
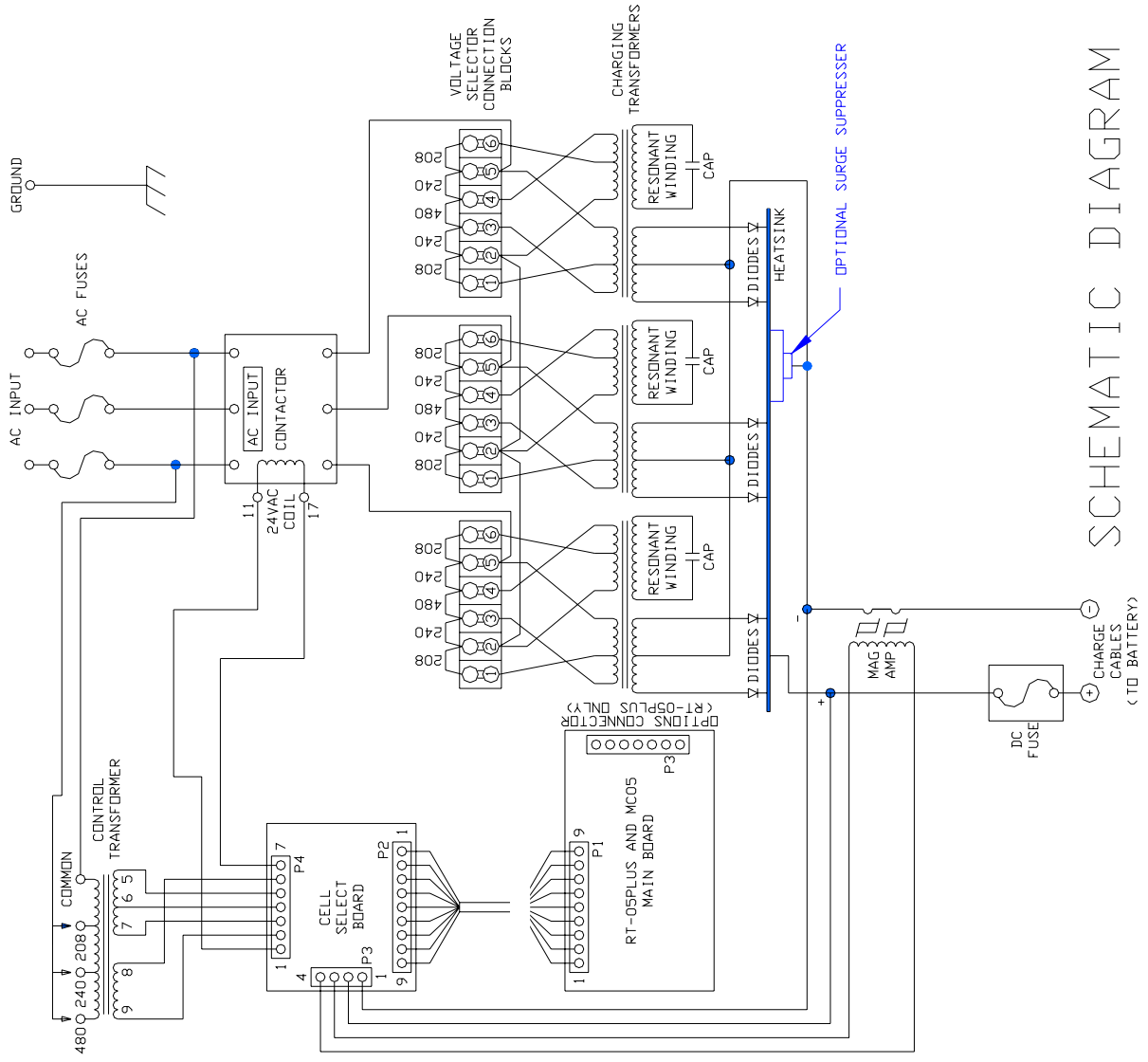

SCHEMATIC DIAGRAM

3 PHASE, 3 TRANSFORMER MODELS

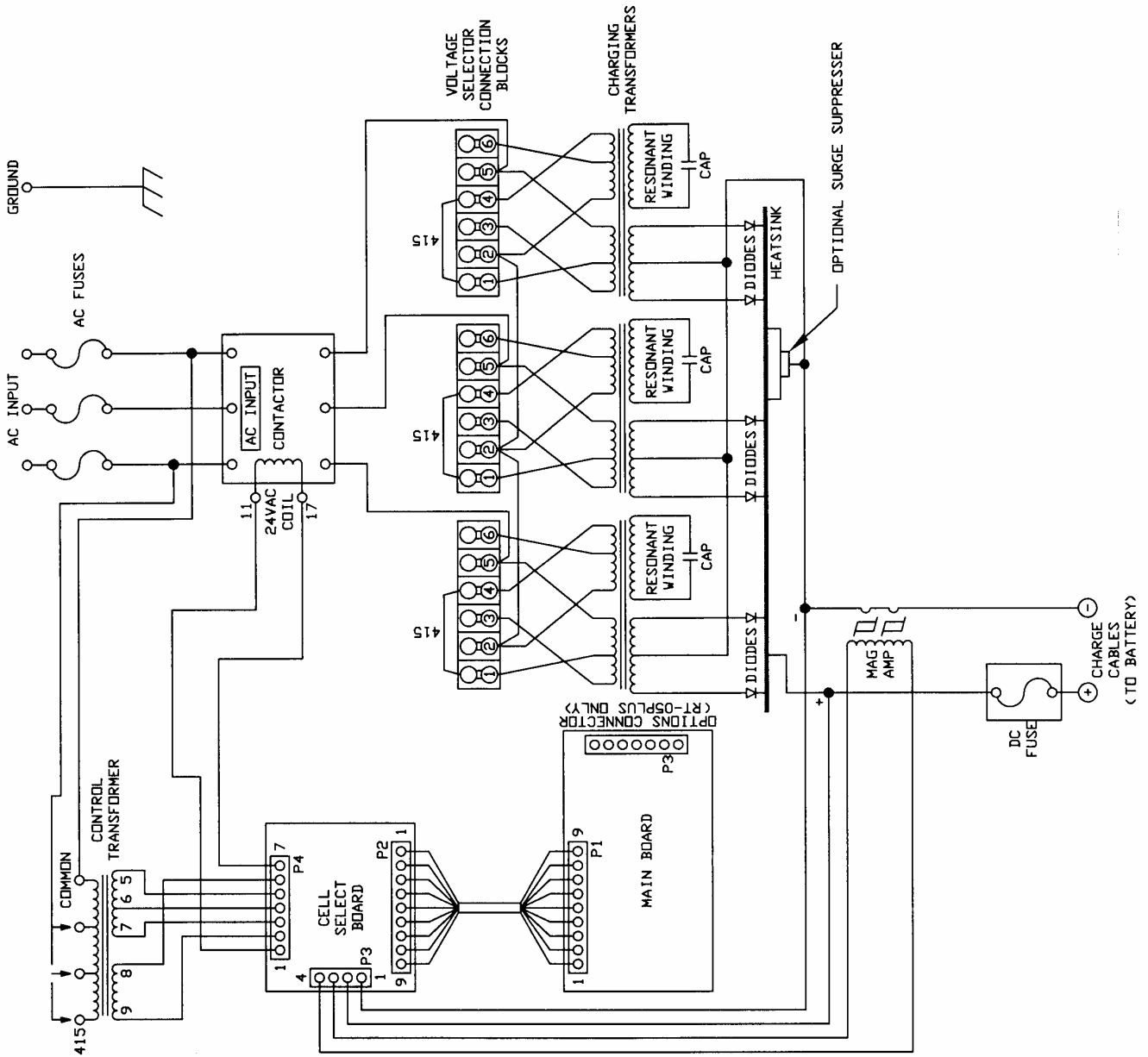

SCHMATIC DIAGRAM
 3 PHASE, 3 TRANSFORMER, 415 VAC MODELS ONLY

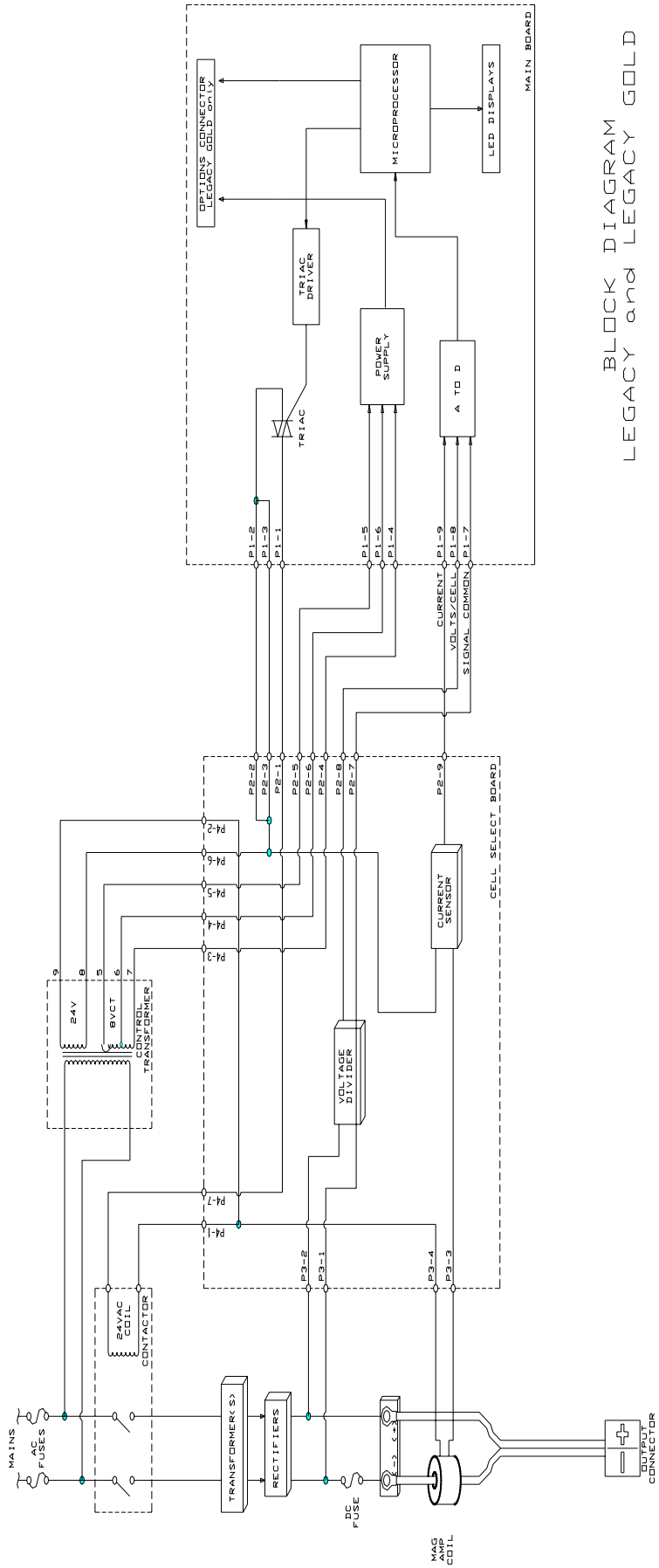

BLOCK DIAGRAM
LEGACY and LEGACY GOLD