

Blum MINIPRESS

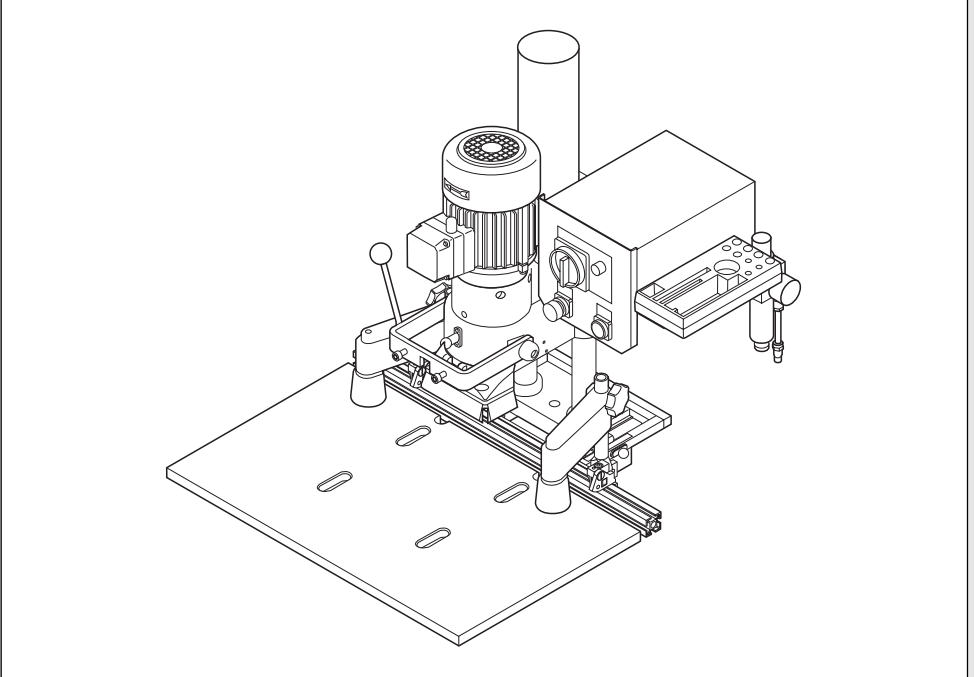

The machine shall only be used by trained personnel who have completely read and understand the manual.

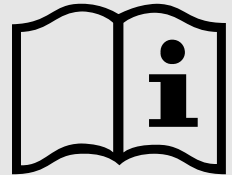

BAU0004823171 IDX00



THE MACHINE SHALL ONLY BE USED BY TRAINED PERSONNEL WHO HAVE COMPLETELY READ AND UNDERSTAND THE MANUAL.

CONTENTS		US	Page:
A	How to use this manual		2
B	Safety instructions		3
C	Designation of parts		6
D	Initial set-up of MINIPRESS		10
	á Unpacking and assembly		10
	á Connection to compressed air system		13
	á Electrical connection		14
	á Dust extraction		14
E	Description of operating panel		15
F	Hinge insertion process		18
	á Drilling of hinge pattern		18
	á Hinge insertion		26
G	Installation of wing mounting plates		29
H	Drilling of line patterns		32
J	Service and maintenance		35
K	Troubleshooting - What to do, if...?	?	38
L	Appendix	i	46
	á Do-it-yourself worktable		46
	á Warranty		47
	á Technical data		48
	á Warranty cards		--





A How to use this manual

1. Understanding this manual

- **THE MACHINE SHOULD ONLY BE USED BY TRAINED PERSONNEL WHO HAVE COMPLETELY READ AND UNDERSTAND THE MANUAL**

- To better identify the machine components, see section C - „Designation of parts“.
- Each section is marked with a capital letter and a symbol that corresponds to the Table of Contents.

2. Symbols and their descriptions:



Indicates important safety rules which must be followed!



Indicates an important comment.

(G1)

Component description code found throughout the manual and on the fold-out pages. The letter corresponds to the section where the component and it's function is described.

Example:
G1 is described in section G.

B

This capital letter indicates the section and is shown on the outer edge of the section. It is intended to aid in searching through the machine manual.



Safety instructions



Safety instructions

Read before operation

B

- Failure to properly follow all safety rules and procedures in this manual, and all warnings and instructions on the machine, may result in serious personal injury or property damage.

Safety decal description



- **Before connecting your machine to a power source, be sure to read ALL Safety Rules and the instruction manual!**



- Wear safety glasses or a full face shield when operating this machine.



- Keep unauthorized people away from the machine. Only one person at a time must operate the machine.



- Disconnect electrical and pneumatic connections before making any repairs or adjustments.
- Electrical connections and maintenance must be performed by a qualified electrician. An electrical diagram is included in the instructions.



Safety instructions

B



- Keep hands and fingers away from drill bits while the machine is power connected, even if it is not running.

- Never attempt to operate machine without the guards in place.



- Never move your hands in the area of pinch points.

Safety rules

- This machine is designed for commercial and industrial applications and shall be used by fully trained professionals only. The machine is only intended for the drilling and insertion of Blum hardware into panels of wood, particle board, or laminated particle board.
- Always place operation mode switch to „set up“ position and disconnect the power (unplugged) before performing any work on the drill heads, fences or stops.
- Keep work area clean. Cluttered areas and work stations increase the chance of accidents.
- Protect yourself from electrical shock. Do not use this machine in damp or wet locations, or expose it to rain.
- Consider environmental factors and local laws when setting-up and operating the machine.
- The hold-down clamps or other adequate means must be used to secure the panel during the operation.
- Observe the location of the control switches and become familiar with their operation.
- Wear proper clothing. Do not wear shirts with bulky sleeves and ties that could be caught in moving parts.
- Do not wear jewelry when operating this machine. Individuals with long hair should wear a hairnet to protect their hair from moving parts.



Safety instructions



- Before every use of the machine, make sure that all safety devices and parts of the machine function properly. Any defective safety devices and accessories must be repaired or exchanged by a qualified service technician only.
- Do not overreach. Keep proper footing and balance at all times.
- CAUTION: For your own safety, use only those accessories which are recommended or indicated in the manual or Blum sales literature.
- All accessories and attachments must be installed as described in the manual to assure a proper and safe operation of the machine.
- Maintain tools with care. Keep tools sharp, clean and organized for the best and safest performance. Follow instructions for lubricating and changing accessories.
- Protect electrical and pneumatic lines from heat, oil, traffic, sharp edges, etc.
- Do not use cables and pneumatic lines for purposes other than those originally intended.
- The actual noise levels in your work area may vary. Appropriate hearing protection may be necessary. This determination must be made by the user with consideration for the entire working environment and any applicable regulation. Factors liable to influence current immission levels in the workplace include the length of exposure, the characteristics of the workroom, and other noise sources.
- This machine, being cord and plug connected is in compliance with OSHA regulations 1910.147 (lock-out / tag-out) and does not require padlocks or other locking devices.
- For any question or problem with the machine, contact the Blum Customer Service Department: 1-800-438-6788

B





Designation of parts

Designation of parts

C

- | | |
|--|---|
| D1 ... machine base | F15 ... clamping lever |
| D2 ... base ruler | F16 ... fixing pin |
| D3 ... clamping lever | F17 ... hold-down clamp |
| D4 ... fencing system | F18 ... locking screw |
| D5 ... fixing pins for ruler | F19 ... hold-down guard |
| D6 ... indexing plate | F20 ... fastening screw for ram |
| D7 ... swivel stop | F21 ... adjustment screw for swing arm |
| D8 ... air filter | F23 ... drill/press unit |
| D9 ... fan | |
| D10 ... rotation direction arrow | |
| E1 ... main switch | J1 ... air filter - water trap |
| E2 ... drill / press stroke button | J2 ... guide shafts |
| E3 ... hold-down switch | J3 ... lubricating nipples |
| E4 ... operation Indicator Lamp | J4 ... motor fastening bolts |
| F8 ... swing arm | |
| F9 ... drilling depth gauge | |
| F10 ... adjustment for drilling depth | |
| F13 ... adjustment screw for stroke speed | |
| F14 ... adjustment screw for braking stroke | |



Designation of parts

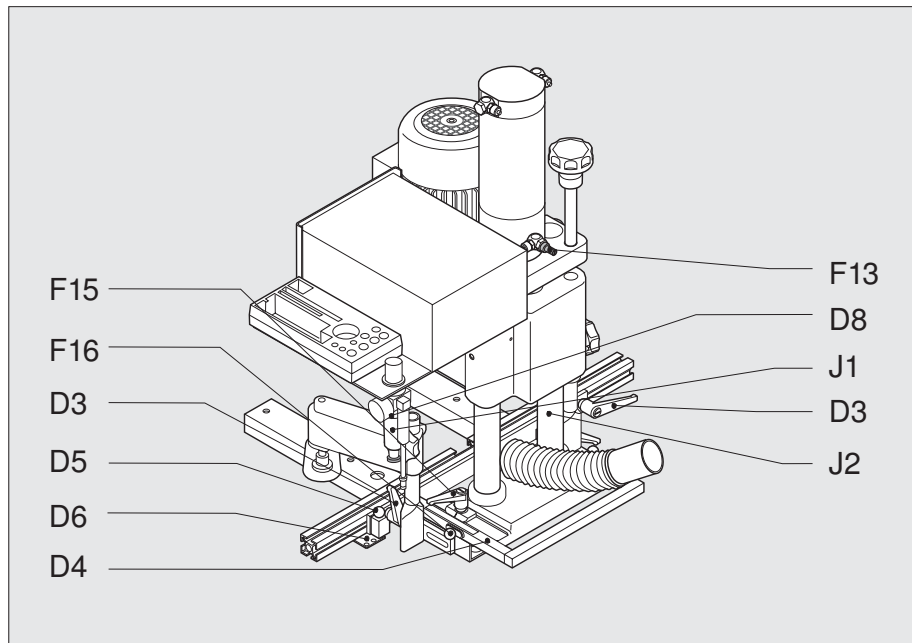
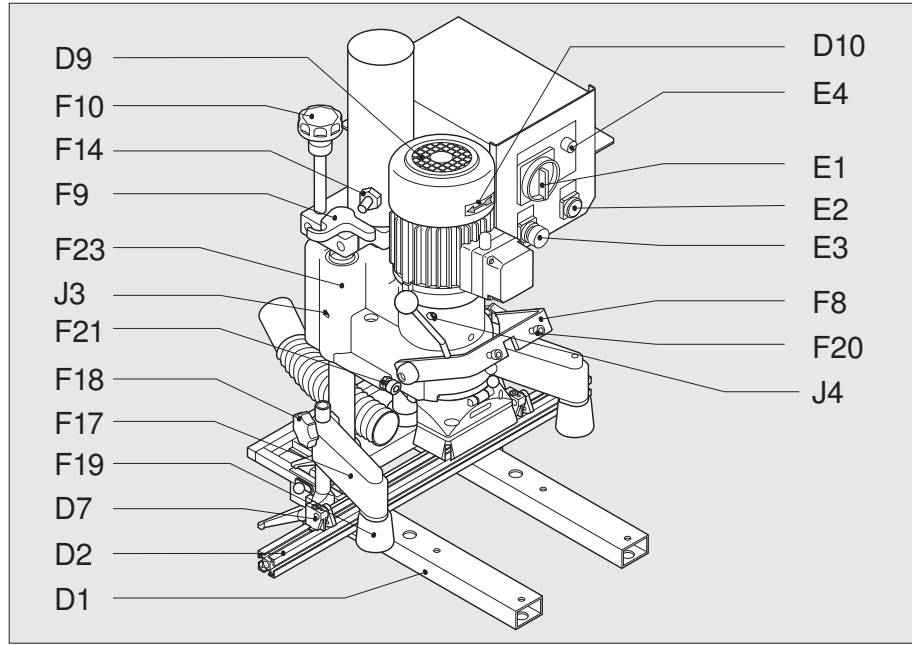



Designation of parts

Designation of parts

D7 ...swivel stop

D13 ...box support

C

F3 ...cover caps

F5 ...fixing pin for drill head

F6 ...lever (to rotate gearbox)

F7 ...symbol furniture hinge

F11 ...drilling depth stop

F12 ...retaining ring

G3 ...symbol line boring pattern

H3 ...setting gauge

J6 ...clutch





Designation of parts

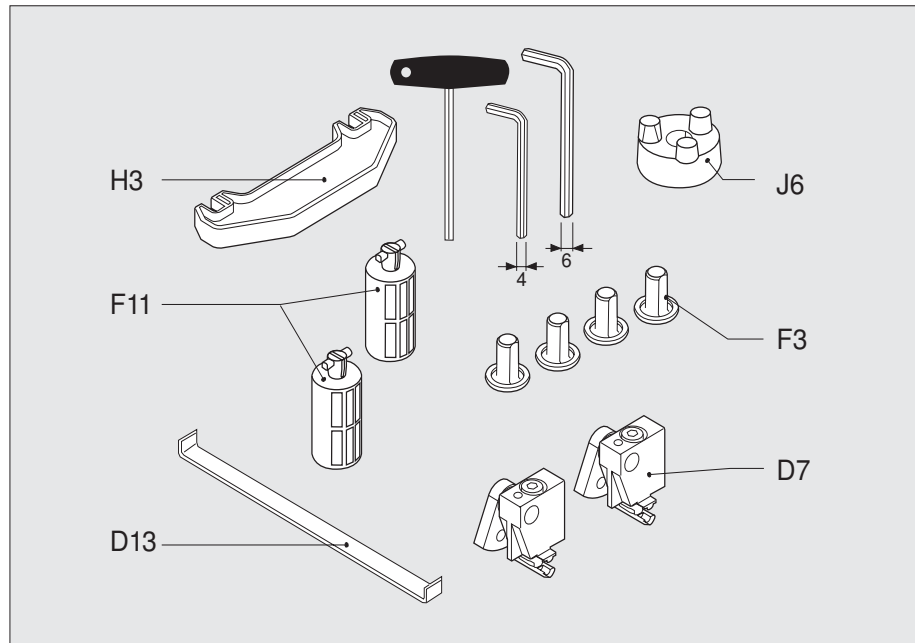
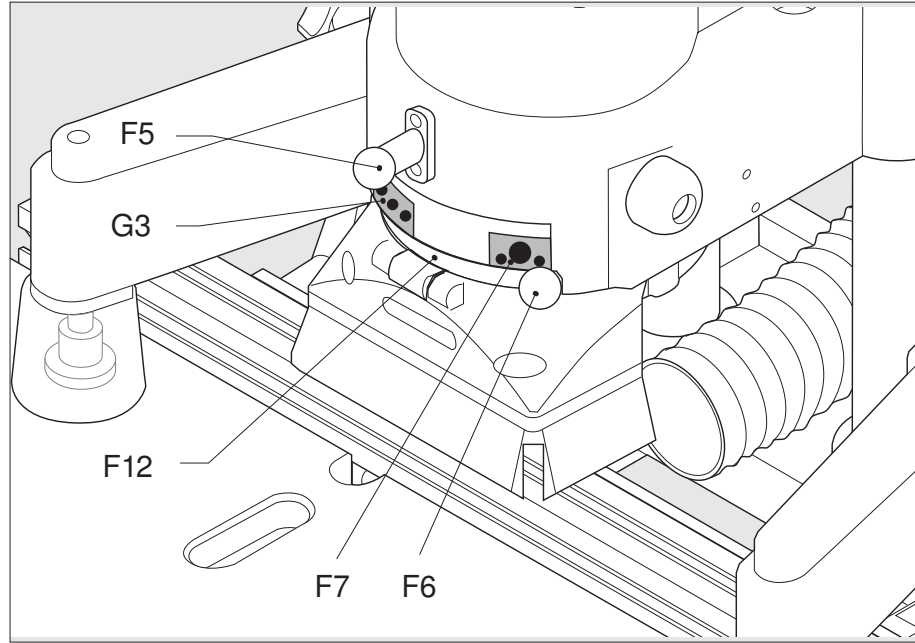

blum

9





Initial set-up of MINIPRESS

Unpacking and assembly

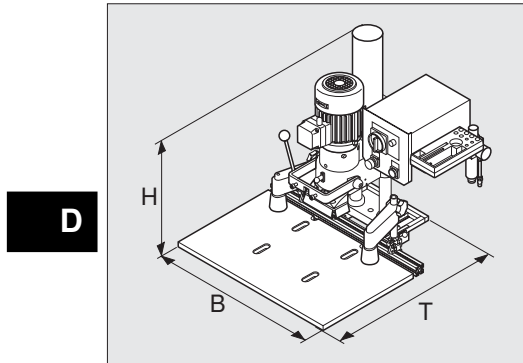

1. MINIPRESS footprint

H = 27-15/16"
B = 24"
T = 29-15/16"

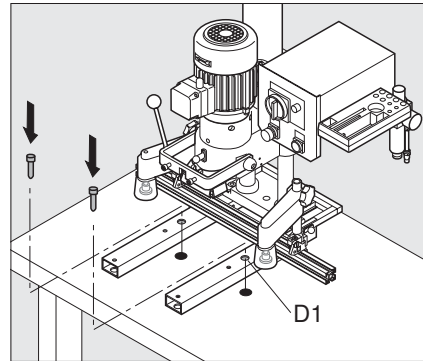

2. Unpack MINIPRESS and fasten it to a suitable table using bolts.

- Open the box.
- Get an assistant to help you lift MINIPRESS onto the worktable.



Warning:
The machine weights
approx. 82 lbs (37 kg) so
make sure that the table is
sturdy enough!

- Fit M8 bolts through the drill holes (D1) and tighten them.
- Do not install MINIPRESS in a damp area but in a dry room.

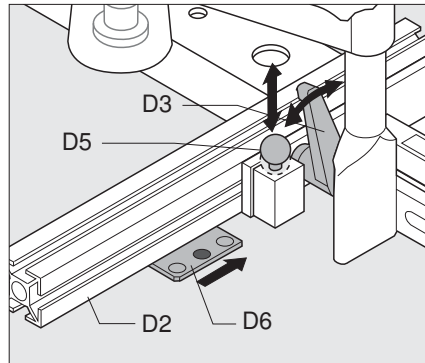

3. Installation of base ruler (D2)

- Loosen both clamping levers (D3) on the fencing System.
- Lift locating pin (D5), and slide base ruler (D2), until the locating pin snaps into the center hole of the locating plate (D6).
- Tighten clamping levers (D3).

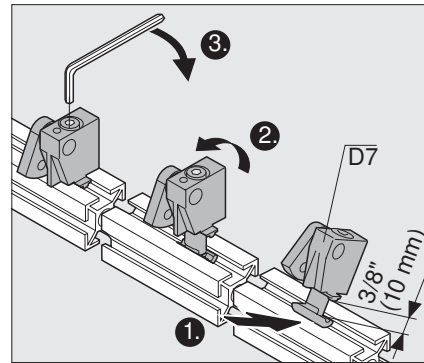

4. Mounting the swivel stops (D7)

- Loosen the locking bolt until the T-nut projects by 3/8" (10 mm).
- Tilt the swivel stop against the ruler and raise the stop.
- Tighten the locking bolt.

Note:

- ! Follow the same procedure to place a stop between two existing stops.



Initial set-up of MINIPRESS

D

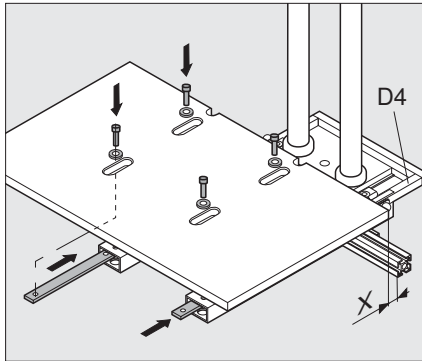

5. Assembling the worktable

a) Accessory worktable MZA.1000

- Set the fencing System (D4) to position DP.
- Place the worktable on the machine base.
- Slide the threaded rail into the hollow profiles and hold them while pushing upward.
- Fit hex set bolts through the holes in the hollow profiles and fasten the table to the counter-plates (x - gap for chips).

b) Do-it-yourself worktable (see page 46)

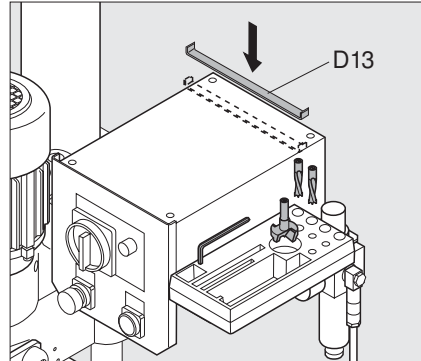

6. Mounting the box Support (D13)

- Use glue to attach the Box Support (D13) to the rear end of the control box (surface must be dry and oil-free).



Connection to compressed air system

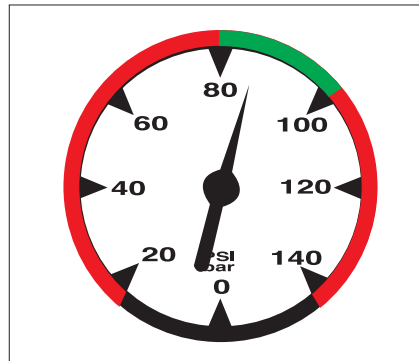
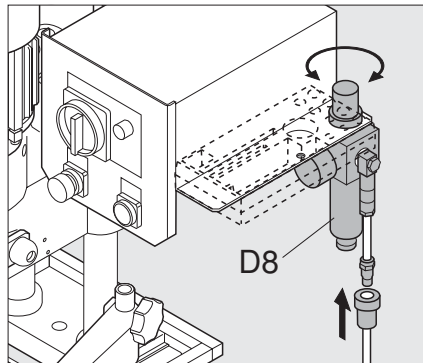

D

1. Connection of air supply

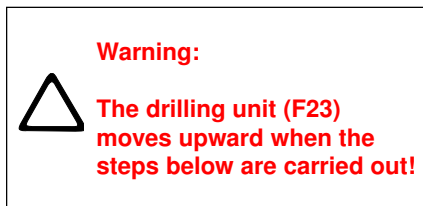

- Attach a 1/4" I.D. flexible hose onto barbed hose fitting (D8) of the machine.

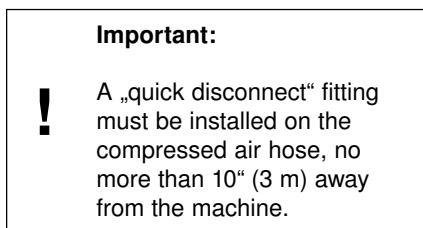

2. Setting the working pressure

- The working pressure is 6 bar (80 - 100 psi). If the machine is operated either below or above the recommended air pressure, could result in personal injury or damage to the machine.
- The compressed air supplied to the machine must be oil free and dry.



Initial set-up of MINIPRESS

Electrical connection

D

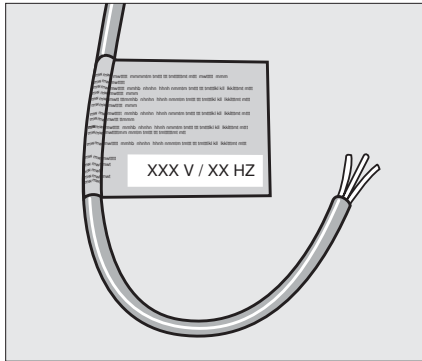

Warning:



Electrical wiring shall be carried out by an authorized electrician only!

1. Electrical connection

- Set main switch (E1) to **set up position**.
- Mount a plug conforming to NEC. This machine must be connected through a circuit breaker (see wiring diagram).

Important:



The machine has been prepared for the voltage printed on the label of the connection cable.

Dust extraction

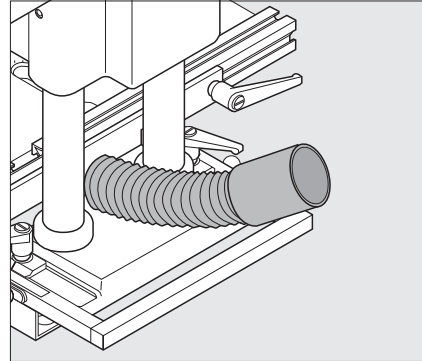

1. This machine may be connected to a dust extraction system.

- Insert a spiral hose with an inside diameter of 3-1/8" (80 mm) into the receiving tube and fix it.
- If no 3-1/8" (80 mm) extraction connection is available, use the adapters (illus. 2) supplied with the machine.

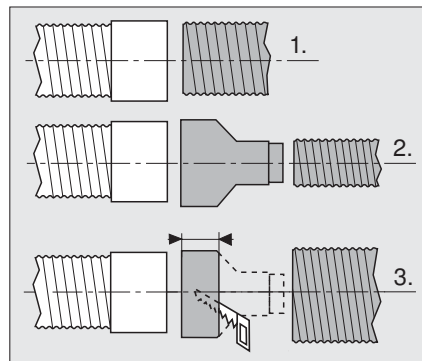



Description of operating panel

Description of operating panel

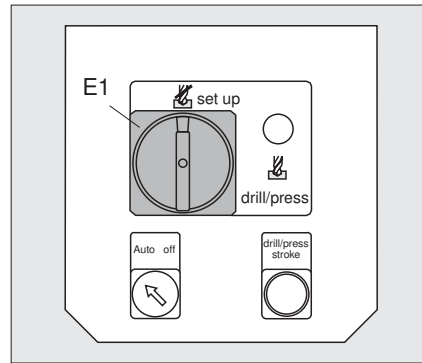
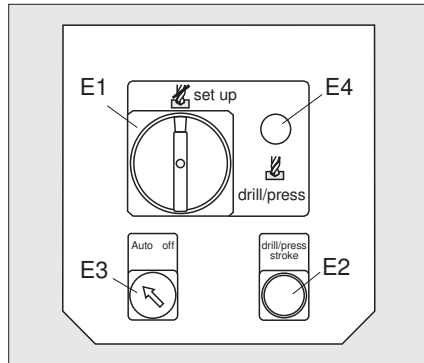

E

2. Designation of operating elements

- (E1) ... main switch
- (E2) ... press drill / press stroke button
- (E3) ... hold-down switch
- (E4) ... operation indicator lamp

3. Main switch (E1)

Warning:



The main switch does not disengage the machine from the compressed-air system.

Set up position:



Operation indicator lamp (E4) does not light up. machine is in set-up mode.

- Motor cannot start.
- stroke can be performed.

drill / press position:



Operation indicator lamp (E4) lights up. machine is in operating mode.

- Drilling and insertion of fittings is possible.



Description of operating panel

E

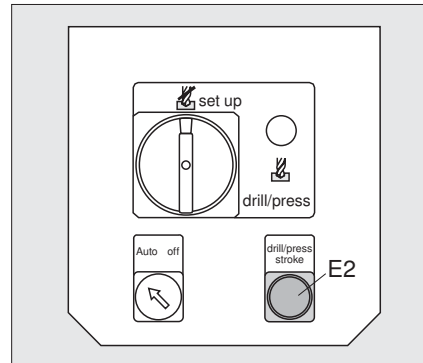
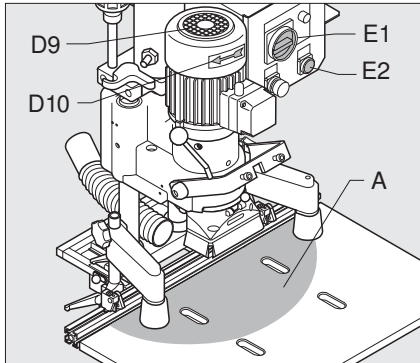

Warning:



Keep your hands out of working area (A) of the machine when performing the tasks below!

4. Checking the motor rotation

- Set main switch (E1) to **drill / press position**.
- Briefly touch the **drill / press stroke button (E2)**.
- The motor fan (D9) must rotate in the direction of the arrow (D10).

Note:



If you press the drill / press stroke button (E2) by only a few mm (1/16"), the drilling and pressing unit will move down at a slower speed.

5. Drill / press stroke button (E2)

Warning:



Keep your hands away from the working area (A) of the machine when pressing the drill / press stroke button.

By pressing the drill / press stroke button, one of the following preselected operations is carried out.

set-up:



main switch to set up position + drill / press stroke button pressed

drilling:



main switch to drill / press position + drill / press stroke button pressed

insertion of fitting:



Swing Arm retracted + drill / press stroke button pressed





Description of operating panel

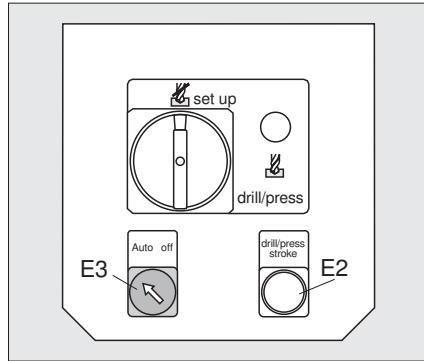

E

5. Hold-down switch (E3)



Pos. Hold-down clamps on
Pressing the drill / press stroke button (E2) causes the hold-down clamps to extend automatically.



Pos. Hold-down clamps off
The clamps remain retracted if you press the drill / press stroke button (E2).



Drilling of hinge pattern

Drilling of hinge pattern

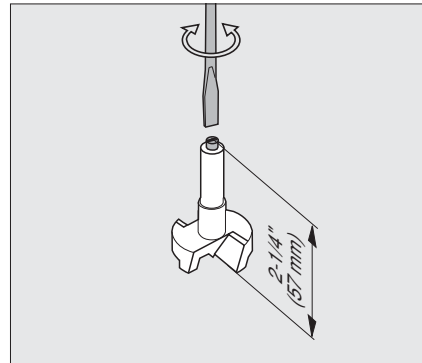
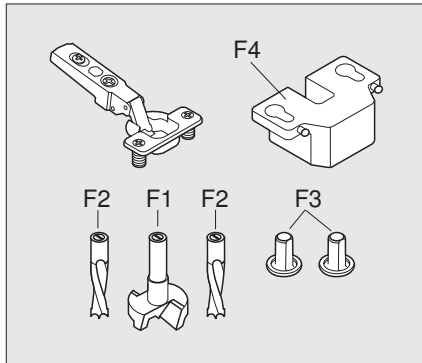

F

1. Necessary parts

- drill bits:
 - one 35 mm dia. rotating clockwise (F1) (marked black).
 - two 8 mm dia. rotating counter-clockwise (F2) (marked orange).
- Two cover caps (F3)
- Insertion ram MZM.XXXX (F4). See Blum catalog for correct ram.
- Door panel
- Hinge

2. drill-bit length

- The max length of the drill bits (from bit-tip to adjustment screw) shall be 2 -1/4" (57 mm).
- To correct drill-bit length, adjust screw accordingly.

Important:



All drill bits shall be the same length!

Drilling of hinge pattern

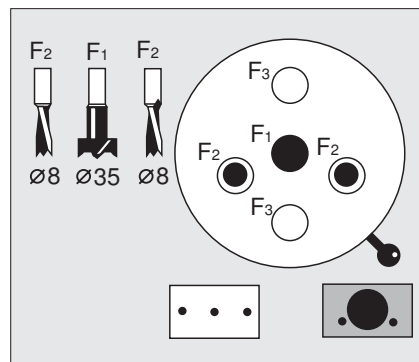
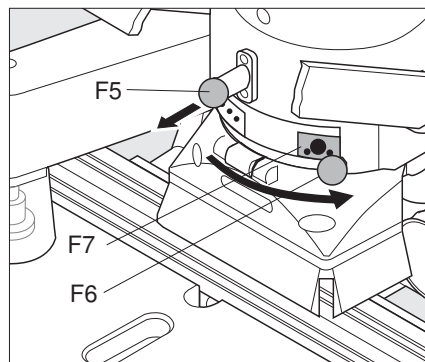

3. Select drill pattern

- Pull out fixing pin (F5) on drill head.
- At the same time, move lever (F6) to symbol for hinge drilling pattern (F7).
- Make sure fixing pin (F5) snaps back to lock gearbox position!

4. Install drill bits

- **Before installing drill bits, always disconnect the machine from its electrical source (unplugged).**
- main switch (E1) to **set up position**.
- Push drill bits all the way in to the chucks. Tighten set screw on flat spot of drill-bit shank only.
- Use a hex wrench to tighten the fastening screws. (4 mm)
- Insert cover cap (F3) into the empty chucks. This keeps set screws in place, and prevents wood chips from accumulating in chucks.

F



Drilling of hinge pattern

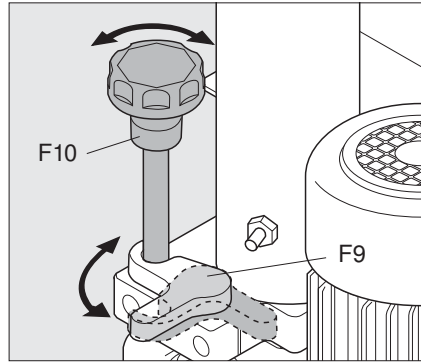
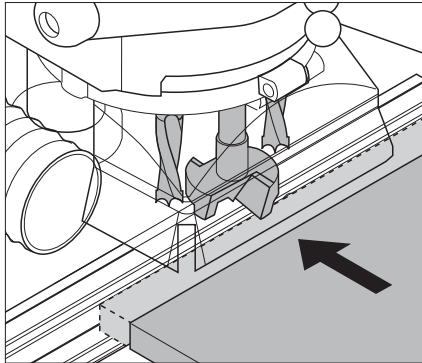

F 5. Check drilling depth adjustment

- Always place operation mode switch to set up position and disconnect the machine from its electrical source (unplugged) before performing any work on the drill heads, fences or stops.

- Hold-down switch (E3) to **pos. off** 
- Move swing arm (F8) into upper position.
- Place door on the worktable clear of drill-head path.
- Move drilling depth gauge (F9) against adjustment screw (see drawing 6).
- Press and hold the drill / press stroke button (E2) to move head down.
- Slide door towards drill bits, and check if the cutting edges of the bits are even with top surface of the door panel.
- Release drill / press stroke button

6. Correcting drilling depth adjustment

- If the Cutting edges do not touch the door panel top, correct adjustment.
- Correct adjustment

lower drilling depth :

turn bolt (F10) clockwise

deeper drilling depth :

turn bolt (F10) counter-clockwise

(One turn on the depth adjustment bolt [E10] equals 1/16" (2 mm) adjustment.)

- Cycle drill / press stroke again, and check adjustment.

Important:



Swivelling out the drilling depth gauge (F9) results in a drilling depth of 1/2" (12.7 mm).





Drilling of hinge pattern

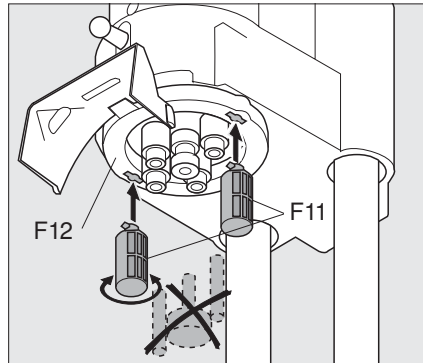

7. Drilling depth stop (F11)

Alternatively, drilling depth stops can be mounted to ensure a constant drilling depth. If these stops are mounted, the drilling depth will always be 1/2" (12.7 mm), **regardless of the thickness of the workpiece.**

Mounting the drilling depth stops:

- Before mounting the depth stops, disconnect the machine from its electrical source (unplugged).
- Main switch to **setup position**.
- Remove the drill bit.
- Push the drilling depth stops into the keyholes of the retaining ring (F12) until they won't go any further and turn them by 90°.

Important:



The drill bit length must be set to 2-1/4" (57 mm) (see section F, item 2). The drilling depth adjuster (F10) bolt must not stop before the drilling depth is reached (turn it back by a sufficient amount).

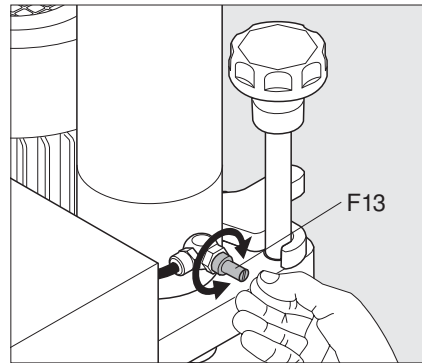

8. Adjusting the stroke speed

F

Adjustment of the stroke speed is made by means of the knurled screw (F13) at the back of the cylinder.

- **faster:** turn screw (F13) counter-clockwise
- **slower:** turn screw (F13) clockwise



Drilling of hinge pattern

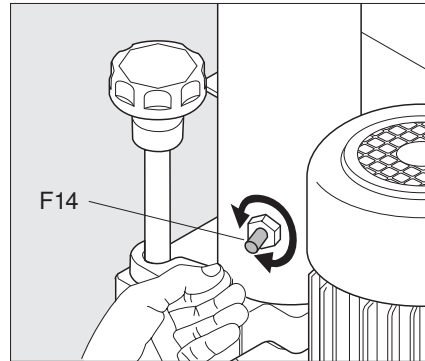
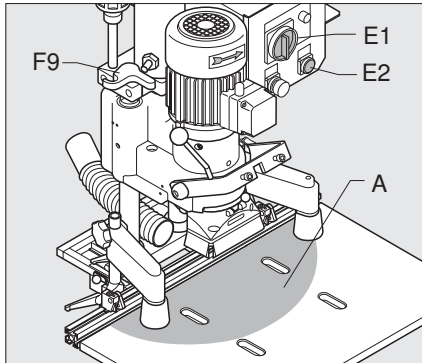

F 9. Checking the pneumatic brake

The pneumatic brake causes the drill head to slow down just before the drill bits penetrate the wood.

(This ensures chip-free holes and longer bit life.)

- Always place operation mode switch to set up position and disconnect the machine from its electrical source (unplugged) before performing any work on the drill heads, fences, stops, or pneumatic brake.
- Main switch (E1) to **set up position**.
- Keep hands and fingers away from drill bits while the machine is power connected, even if it is not running.
- Swivel out the drilling depth gauge (F9).
- Press the drill / press stroke button (E2) and watch stroke.

10. Adjusting the pneumatic brake

To adjust the pneumatic brake, use the screw (F14) on the left side of the cylinder.

- **Hardwood:** turn screw (F14) clockwise for major deceleration of drill stroke.
- **Softwood:** turn screw (F14) counter-clockwise for minor deceleration of drill stroke.

Drilling of hinge pattern

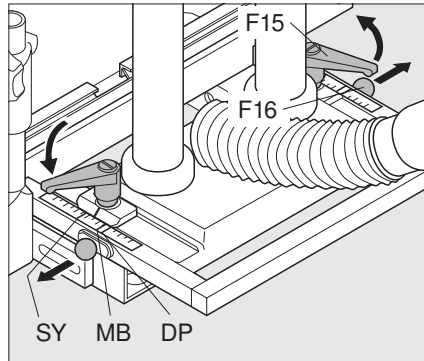

11. Fencing System (D4) adjustments

- Always place operation mode switch to set up position and disconnect the machine from it's electrical source (unplugged) before performing any work on the drill heads, fences, stops, or pneumatic break.
- Release both clamping levers (F15).
- Pull out the fixing pins (F16) on both sides and set the stop system (D4) to **MB**.

Note:



The fencing system includes 5 fixing positions. (see point 12)

- Tighten the clamping levers (F15) on both sides.

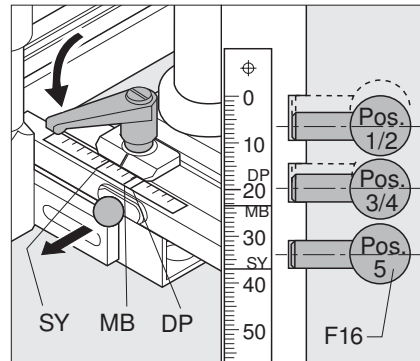

12. Fixed positions of the stop system

F

- Always place operation mode switch to set up position and disconnect the machine from it's electrical source (unplugged) before performing any work on the drill heads, fences, stops, or pneumatic break.

Pos. 1 = 5 mm (3/16")

Lock the fixing bolts (F16) into place and pull the stop system forward.

Pos. 2 = 9 mm (3/8")

Lock the fixing bolts (F16) into place and push the stop system backward.

Pos. 3 = 20 mm (13/16")

Lock the fixing bolts (F16) into place and pull the stop system forward.

Setting: 'DP'

Pos. 4 = 23.5 mm (15/16")

Lock the fixing bolts (F16) into place and push the stop system backward.

Setting: 'MB'

Pos. 5 = 37 mm (1-7/16")

Lock the fixing bolts (F16) into place.

Setting: 'SY'



Drilling of hinge pattern

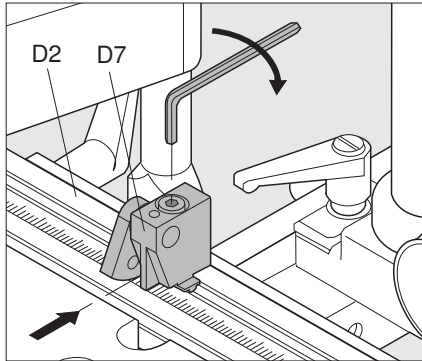

F 13. Setting the swivel stops (D7)

- Always place operation mode switch to set up position and disconnect the machine from it's electrical source (unplugged) before performing any work on the drill heads, fences, stops, or pneumatic break.

Set the swivel stops (D7) to the required dimension and secure them.

Note:
! The reading edge is on the inside of the swivel part!

14. Place the door on the worktable and slide it until positioned at the stop.

Note:
! For work pieces with grooves or radii (see illus.), the stop face can be increased by pulling the stop lock forward.



Drilling of hinge pattern

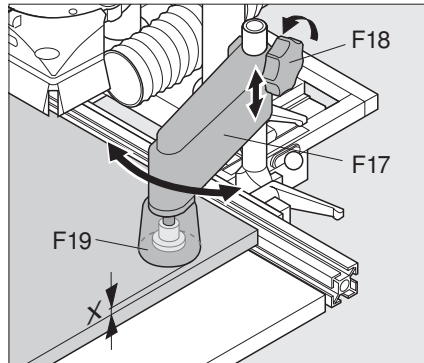

15. Adjust hold down clamps (F17)

- Loosen clamp screw (F18).
- Position clamp over panel surface.
- Position clamp over panel surface, no more than 6 mm (1/4").
- Tighten clamp screws (F18).

F



Hinge insertion

Hinge insertion

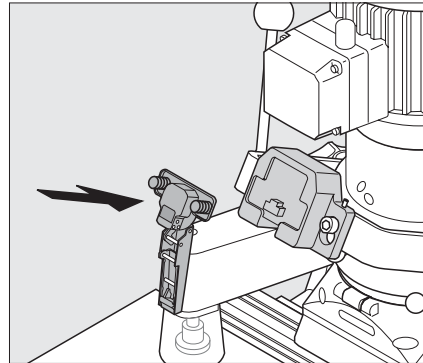
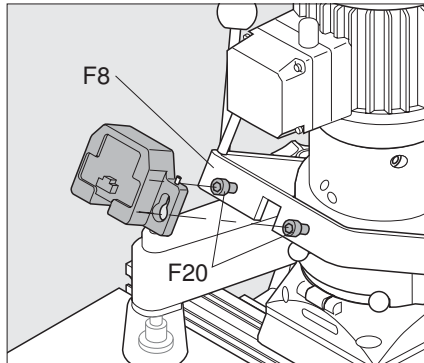

F 16. Mount insertion ram onto swing arm (F8) in upright position

- Place ram over fixing bolts (F20) on swing arm (F8) and tighten.
- Make sure that ram adjustment screws sit on fixing bolt.

17. Attaching the hinge on to the ram.



Hinge insertion

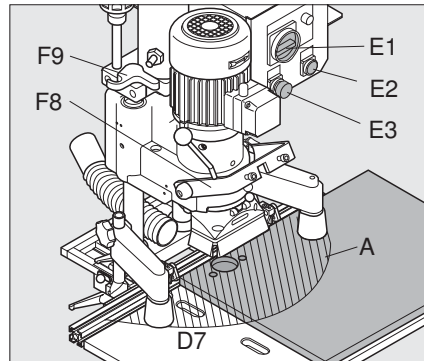

18. Drilling



WARNING!
To avoid serious injury, all items must be removed from the working area of the machine, except the workpiece! Keep your hands out of working area (A).

- Swivel out the drilling depth gauge (F9).
- Set the main switch (E1) to **drill / press position**.
- Set the hold-down switch (E3) to **pos. off** 
- Be sure to swivel the swing arm (F8) upward.
- When drilling, keep one hand against the outside edge of the door nearest to you (outside of zone A) and push it against the swivel stops - D7.
- Press the drill / press stroke button (E2) until the drilling depth is reached.
- Release the drill / press stroke button

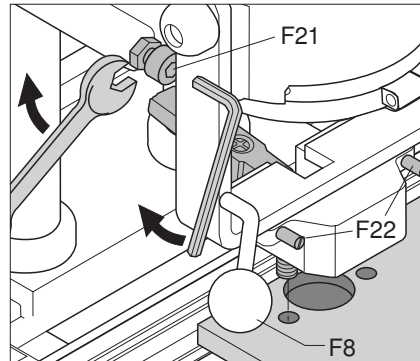

19. Check alignment of swing arm (F8)

F

- Move Swing Arm (F8) down to stop
- Make sure the hinge is aligned with the drilled hole.
- There are two possibilities which could cause misalignment:

- Swing arm (F8) is not vertical:** adjust screw (F21).
- Insertionram is off center:** adjust ram adjustment screws (F22).

Note:

If you press the drill / press stroke button (E2) by only a few mm (1/16"), the drilling and pressing unit will move down at a slower speed.



Hinge insertion

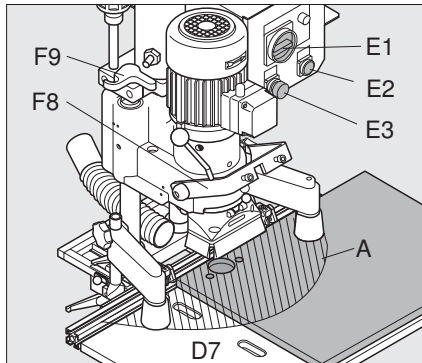

F 19. Hinge insertion

WARNING!



To avoid serious injury stay clear of drilling area and all pinch points (zone A) except the workpiece.

- When inserting hinge, keep one hand on the drill / press stroke button (E2) and the other hand on the swing arm (F8) or on the edge of the door nearest you until the hinge is totally pressed in (outside of zone A).
- Release drill / press stroke button.
- Move swing arm (F8) up.
- Release the hold-down clamps by briefly touching the hold-down switch (E3).



Installation of wing mounting plates with system screws

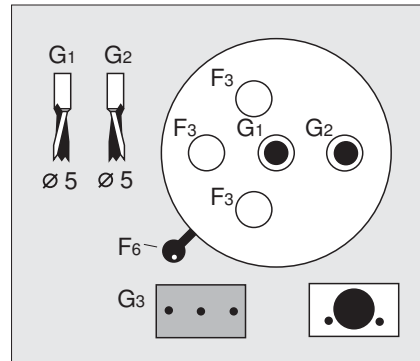
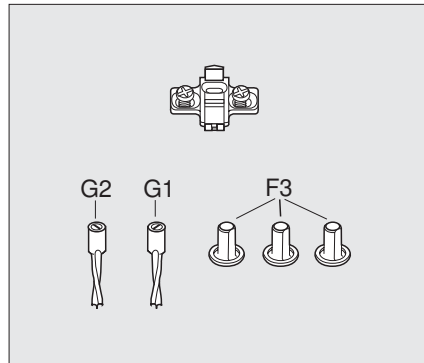

1. Necessary parts

- Drill bits:
 - one 5 mm dia. rotating clock wise (G1) (marked black)
 - one 5 mm dia. rotating counter clockwise (G2) (marked orange)
- Three cover caps (F3)
- Cabinet side panel
- Mounting plates with system screws

2. Drill-bit length

(see section F- point 2)

3. Change drill pattern

- Pull out fixing pin (F5) on drill head.
- At the same time, move lever (F6) to Symbol for line boring pattern (G3).
- Make sure, fixing pin snaps back to lock gearbox position.

4. Install drill bits

(see section F- point 4)

5. Check drilling depth adjustment

(see section F - points 5/6/7)

6. Check pneumatic brake setting

(see section F -point 8/9/10)





Installation of wing mounting plates

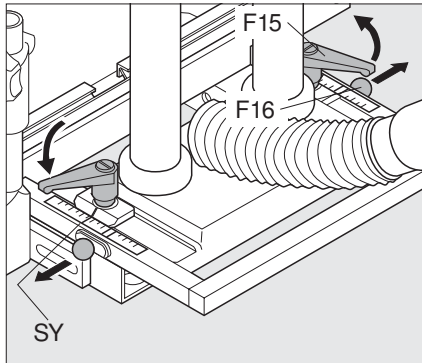

7. Setting the fencing system (D4)

- Always place operation mode switch to set up position and disconnect the machine from its electrical source (unplugged) before performing any work on the drill heads, fences, stops, or pneumatic break.
- Release both clamping levers (F15).
- Pull out both fixing pins (F16) and set the stop system (D4) to **SY**.
- Firmly tighten both clamping levers (F15).

This fixed setting provides for a drilling distance of 1-7/16" (37 mm).

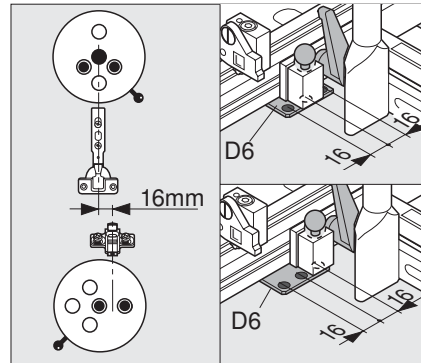

8. Setting the swivel stops (D7)

- Always place operation mode switch to set up position and disconnect the machine from its electrical source (unplugged) before performing any work on the drill heads, fences, stops, or pneumatic break.
- a) If the lower edge of the door is to be flush with the lower edge of the cabinet, only the base ruler (D2) needs to be repositioned.

Repositioning the base ruler:

- Release the two clamping levers (D3) which hold the ruler in place.
- Lift up the fixing pin (D5) and move the ruler (D2) in the direction of the outer drill bit until the fixing pin (D5) locks into the outer drill hole of the indexing plate (D6).
- Firmly tighten clamping levers (D3).

Note:
 This step compensates for the 0-point offset of the wing mounting plate (see illus. 8).





Drilling of line patterns

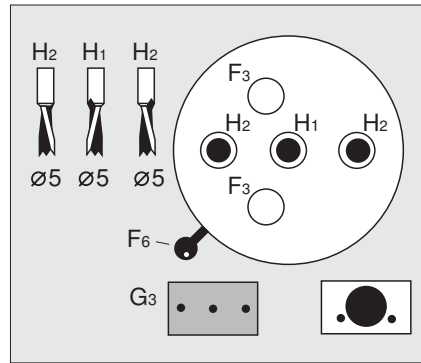
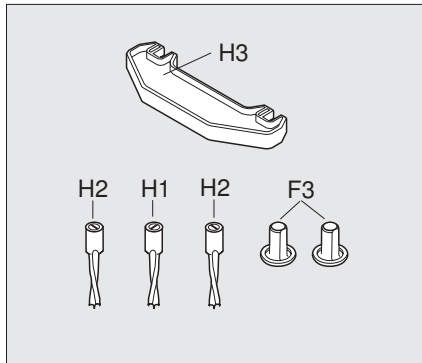

1. Necessary parts

- Drill bits:
one 5 mm dia. rotating clockwise (H1) (marked black)
two 5 mm dia. rotating counter clockwise (H2) (marked orange)
- Two cover caps (F3)
- Distance gauge for positioning stops (H3).
- Cabinet side panel

2. Drill bit length

(see section F - point 2)

3. Change drill pattern

- Pull out fixing pin (F5) on drill head.
- At the same time, move lever (F6) to symbol for line boring pattern (G3).
- Make sure, fixing pin snaps back to lock gearbox position.

4. Install drill bits

(see section F - point 4)

5. Check drilling depth adjustment

(see section F - points 5/6/7)

6. Check pneumatic brake setting

(see section F - points 8/9/10)



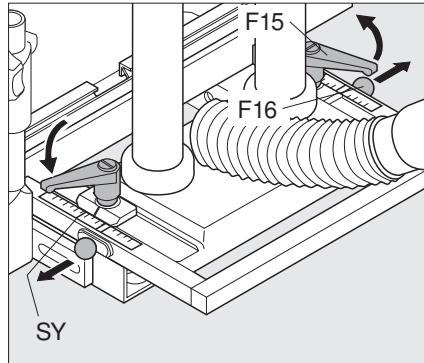

7. Adjust fencing system (D4)

- Always place operation mode switch to set up position and disconnect the machine from its electrical source (unplugged) before performing any work on the drill heads, fences, stops, or pneumatic brake.
- Release clamping levers (F15).
- Pull out locating pin (F16), and adjust fencing system (D4) to pos. SY.
- Tighten clamping levers (F15).

With this adjustment, the distance between fence and the centerline of the drill bits is 37 mm.

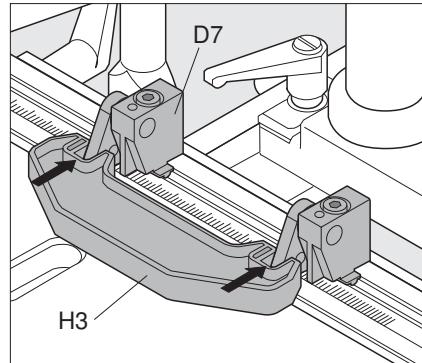

8. Adjust positioning stops (D7) (see section F - point 13)

9. Line boring

- Use Distance Gauge (H3) to set additional positioning stops.

This will set a 3-3/4" (96 mm) distance between the stops and provide a consecutive 1-1/4" (32 mm) line boring pattern.

H



Drilling of line patterns

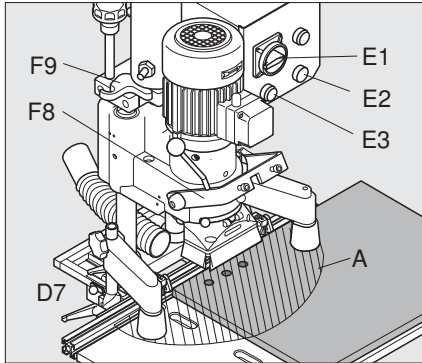

10. Slide cabinet side panel against the fence until positioned at the stop
(see section F- point 14)

11. Adjust hold down clamps (F17)
(see section F - point 15)

H

12. Drilling
(see section F - point 18)

13. Releasing hold down clamps

- Briefly touch the down-hold switch (E3).
- Position cabinet side panel to the next stop.

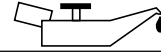

Maintenance

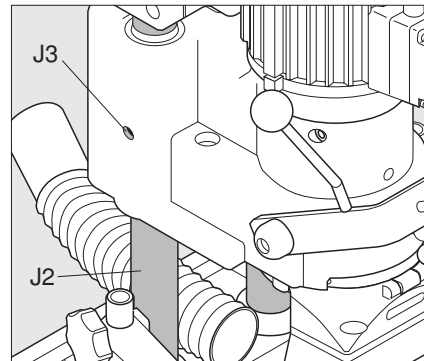
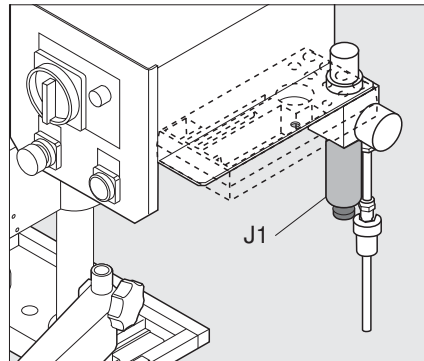

1. Maintenance

- During all maintenance operations, disconnect the machine from its electrical source (unplugged). Re-connect only for testing.
- Regularly remove drilling dust from the machine.
- Before every use of the machine, check the air filter unit (J1) for water which may accumulate in the filter unit. Empty the unit if necessary.
- Before every use of the machine, check the pneumatic lines and electrical lines for damage.
- The guide elements (J2) must be cleaned regularly with a dry cloth to remove dust. (Do not use cleaners or solvents)

J

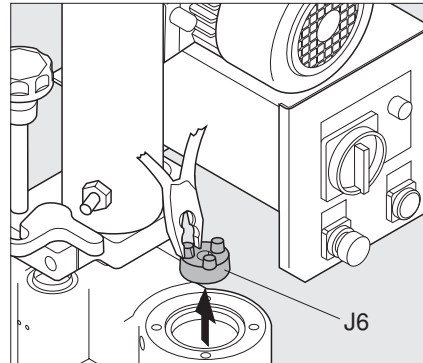
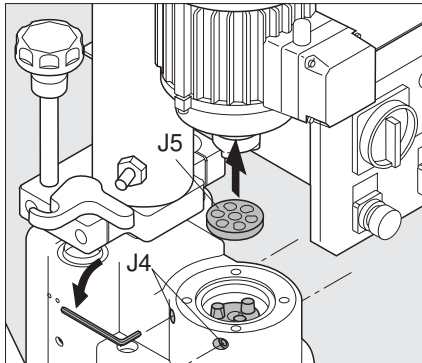
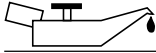

2. Replacing a damaged clutch

The clutch is defective if:

- The drill bits get jammed in the workpiece while the motor fan (D9) keeps on rotating.

Warning !



Replace defective or damaged parts immediately! Use only original BLUM parts for replacement!

- Set main switch to **set up position**.
- **When replacing a damaged clutch, machine must be disconnected from its electrical power source and from its compressed air supply and pressure released from machine (use filter bowl drain).**
- Remove drill bit.
- Release the four lateral fastening bolts (J4) from the motor (requires about 4 complete turns).

- **Lift the motor and rest it on the control system.**



Warning:

Secure the motor against dropping!

- Remove the damping ring (J5).
- Remove the old clutch (J6).
- Mount the new clutch (J6) on the shaft (ensure correct position between clutch and shaft).
- Insert the damping ring (J5).
- Position the bottom part of the clutch ready to receive the motor.
- Place the motor on the bottom part of the clutch and make sure that it rests properly on the flange.
- Tighten the four lateral fastening bolts (J4).



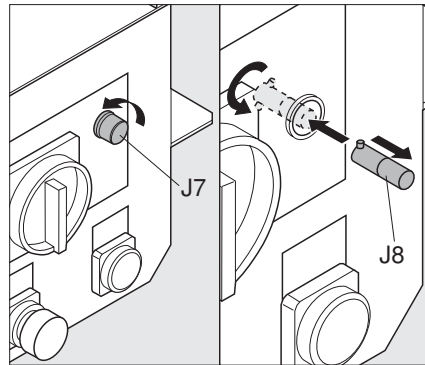
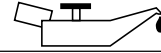

3. Replacing the operation indicator lamp

- **Disconnect the machine from the electrical supply.**
- Set the main switch to set up position.
- Remove the lamp cover (J7) by releasing the screw.
- Remove the defective lamp (J8). (Push and turn counter-clockwise).
- Install a new lamp (J8). (Push and turn clockwise).
- Reattach the cover (J7) of the operation indicator lamp.

J

**Fault during drilling**

Fault	Cause of fault	Eliminating fault	Remarks
• Drilling depth is not reached	• Setting of depth adjustment bolt is wrong	• Check setting of the depth adjustment bolt	See chapter F F-10
	• Drilling depth gauge swung in	• Swing out drilling depth gauge	See chapter F F-9
	• Drill shorter than 2-1/4" (57 mm)	• Adjust drill bit	See chapter F
	• Drill bits not completely pushed into the chucks	• Clean chucks and push drill bit completely into the chuck	See chapter F
	• Panel thickness is different than assumed thickness (e. g. 9/16" (15 mm) instead of 5/8" (16 mm))	• Check panel thickness	No comments
		• Adjust drilling depth if necessary • Use drilling depth stop	See chapter F See chapter F
	• Machine hits an object during down stroke	• Remove object	No comments
	• Drill / press stroke button was released before drilling depth was reached	• Press the drill stroke button until the drilling depth is reached	No comments
• Worktable lower than 15/16" (24 mm)	• Build up the worktable to 15/16" (24 mm) height	No comments	

K



Fault during drilling

Fault	Cause of fault	Eliminating fault	Remarks
	<ul style="list-style-type: none"> Pneumatic brake is set too tight 	<ul style="list-style-type: none"> Slightly open the throttle valve 	See chapter F
<ul style="list-style-type: none"> Drilled holes are off-center or hole position is incorrect 	<ul style="list-style-type: none"> The fence stops are set wrong 	<ul style="list-style-type: none"> Check position of fence stops and adjust if necessary 	No comments
	<ul style="list-style-type: none"> Ruler incorrectly set 	<ul style="list-style-type: none"> Adjust ruler 	No comments
	<ul style="list-style-type: none"> Wood chips are between the fence and the fence supports 	<ul style="list-style-type: none"> Remove wood chips and dirt from fence support 	No comments
	<ul style="list-style-type: none"> Fencing System incorrectly set 	<ul style="list-style-type: none"> Check setting and if necessary rectify 	See chapter F
	<ul style="list-style-type: none"> The fence extension is not installed properly 	<ul style="list-style-type: none"> Check fence extension and fence extension supports 	No comments
		<ul style="list-style-type: none"> Check the distance between the rulers 	No comments
	<ul style="list-style-type: none"> Gear box does not engage 	<ul style="list-style-type: none"> Allow fixing pin for drill head to engage 	See chapter F
<ul style="list-style-type: none"> Location pin does not engage into the locating plate 	<ul style="list-style-type: none"> Check position of the location pin 	See chapter D and G	

K



?

Troubleshooting - What to do, if ...?

Fault during drilling

Fault	Cause of fault	Eliminating fault	Remarks
• Drilled holes too large, oval or ragged	• Drill bit diameter too large	• Check drill bit diameter	No comments
	• Drill bit is bent	• Replace drill bit	No comments
	• Drills bits are dull	• Regrind or replace drill bit	No comments
	• Stroke speed too high for drilling	• Adjust stroke speed	See chapter F
	• The panel was drilled through completely	• Adjust drilling depth	No comments
	• Gearbox shafts are bent	• Replace gearbox	No comments
• Drill bits get stuck in the panel	• Panel material other than stated in the intended use of this machine was used	• Only panels of wood, particle board or laminated particle board are to be used	No comments
	• Down stroke speed during drilling is too fast	• Adjust down stroke brake properly	See chapter F
	• The clutch is damaged (the drill bits get jammed in the workpiece while the motor fan keeps on rotating)	• Replace defective clutch	See chapter I

K



Fault during drilling

Fault	Cause of fault	Eliminating fault	Remarks
	• Drill bits are dull	• Replace or sharpen drill bits	No comments
	• Wrong motor rotation	• Correct the motor rotation	See chapter D
	• Wrong handed drill bits are used	• Install left hand drill bits into chucks marked in orange and right hand drill bits into chucks marked in black	No comments
	• Motor connected to wrong voltage	• Check the main voltage and compare with motor data. If voltage wrong, replace machine	See electrical schematic
• Drill bit cannot be inserted in to the chuck.	• Drill chuck very dirty	• Clean drill chuck - Use cover cap!	No comments
	• Drill shank diameter too large	• Replace drill bit	No comments

K



Fault during Hinge insertion

Fault	Cause of fault	Eliminating fault	Remarks
• Hinges or fittings cannot be inserted at all, or can only be inserted with difficulties	• Air pressure is not sufficient	• Adjust air pressure to 6 bar (80-100 psi)	No comments
	• The insertion ram or the swing arm is hitting an object	• Remove object from path of insertion ram or swing arm • Check drilling distance	No comments
	• The surface of the panel is too hard	• Countersink holes	Use countersink bit
	• The drilling depth is not deep enough	• See point: Wrong drilling depth	No comments
	• The diameter of the drill bits is too small	• Check drill bits and replace if necessary	No comments
	• The insertion ram is off-set or installed wrong	• Adjust insertion ram	See section F
	• The panel moved on the work table before the insertion cycle	• Adjust hold-down clamps so panel does not move during the operation	See section F
	• Shavings in holes	• Check the shavings air jet • drill deeper, if possible	No comments
	• Insertion ram or swing arm is displaced or twisted	• Adjust insertion ram or swing arm	See section F

K



Functional fault

Fault	Cause of fault	Eliminating fault	Remarks
• Motor does not run	• Machine not connected to electrical source	• Connect machine to electrical source	No comments
	• Machine not connected to air supply	• Connect machine to air supply	No comments
	• Circuit breaker has been thrown or fuse has expired	• Switch on or replace fuse	No comments
	• Fuse under the control panel has expired	• Repair by authorized electrician or Blum repair center	See electrical schematic
	• Switch not on	• Main switch on Pos.1	See section E
	• Swing arm is moved down	• Move swing arm up	See section F
	• Motor connected to wrong voltage	• Check main voltage and compare with motor data. Replace machine if voltage is wrong	See electrical schematic
	• Motor defective	• Replace motor by authorized electrician or return to Blum repair center	No comments

K



Troubleshooting - What to do, if ...?

Functional fault

Fault	Cause of fault	Eliminating fault	Remarks
• Motor overheats	• Motor connected to wrong voltage	• Check main voltage and compare with motor data. If voltage is wrong, replace machine	See electrical schematic
	• Drilling in hard wood with too great a stroke speed	• Adjust stroke speed	See section F
	• Motor is so dusty that cooling is not possible	• Clean dust off machine	No comments
• Machine does not cycle when the drill / press stroke button is activated	• Machine not connected to air supply	• Connect machine to air supply	See section D
	• Air pressure not sufficient	• Adjust air pressure (min 80 psi to max 100 psi)	See section D
	• Hose has a kink in it	• Examine air hose	No comments
	• Throttle valve of the pneumatic brake is closed	• Adjust pneumatic brake	See section F

K



Troubleshooting - What to do, if ...?



Functional fault

Fault	Cause of fault	Eliminating fault	Remarks
	• Drill / press stroke valve defect	• Repair by Blum repair center	No comments
	• Cylinder defect	• Repair by Blum repair center	No comments
• Hold-down clamp malfunctions	• Wrong switch position	• Check switch position	See section E
	• Hold-down clamp valve defect	• Repair by Blum repair center	No comments
• Operation indicator lamp does not light	• Operation indicator lamp defective	• Replacing the lamp	See section J
	• Control circuit- fuse defective	• Replace control circuit fuse by an authorised electrician only	No comments
• Air filter connection leaks	• Angle screw does not seal	• Replace angle screw or use sealing agent	No comments
	• Other faults	• Replace air filter	No comments
• Shavings air jet is too weak	• Air hose is kinked or there is a leaky connection somewhere	• Replace the air hose	No comments
	• Shavings air jet is misadjusted	• Reset shavings air jet by turning the air hose	No comments
• Gearbox is defective	• Bearings, gears or spindles are defective	• Replace gearbox	No comments

K



i

Appendix

Do-it-yourself-worktable

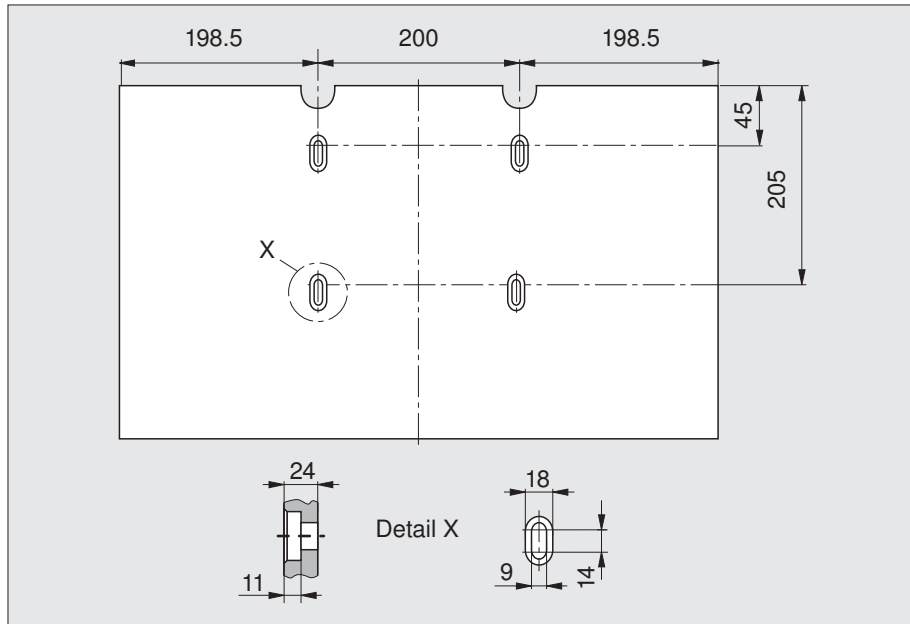

- Use plywood or laminated wood for the worktable!
- Use M8 bolts with nuts and washers to secure the worktable, or order the Blum mounting set MZA.1002.

L



Limited warranty

The Blum MINIPRESS has been manufactured using the highest quality materials to provide long lasting performance.

Rigorous quality controls and a final inspection ensures that each machine is delivered in good working condition. These quality control measures enable Blum to offer this one year limited warranty on the machine, starting with the date of delivery. (Please return the enclosed „Warranty Reply Card“ to our address).

The Blum MINIPRESS is warranted to be free of defects in materials and workmanship for a period of one year from the date of purchase. **This warranty is in lieu of any other warranties expressed or implied.**

This warranty does not include any implied warranties of fitness or merchantability, such warranties are specifically excluded.

In no event shall Blum be liable for any incidental or consequential damages, damage in transportation, damage from misuse or improper handling of machine, lost production time or materials, parts which are subject to normal wear (such as drill bits), or for any other damages directly or indirectly arising from the sale, except as provided specifically in this warranty.

Some portions of this warranty may not be applicable due to provisions of State Law. The non-applicability of any portion of this warranty shall not affect the remaining terms and conditions of the warranty.

Any damages under this warranty shall be limited to a maximum of the purchase price of the machine.

Should any defect be found in the machine, please submit to Blum, in writing, the reference number, the serial number, and the name of the distributor from whom the machine was purchased. Replacement parts included under this warranty will be furnished, free-of-charge.

This warranty is also subject to the specific terms and conditions set forth in the purchase agreement for this equipment. The warranty language in the purchase agreement shall govern in the event of any difference in terms.





i

Appendix

Technical Data

1. General data

- Voltage: See type plate
- Power supply: See type plate
- Connected load motor: 1.1 kW
- rpm: See type plate
- Compressed air: 80 - 100 psi
- Air consumption: 1.5 liters per cycle

3. Maximum thickness of workpiece

- Drilling only: 1-3/4" (45 mm)
- Insertion of fittings depending on fitting:
 - max. 13/16"
 - max. (20 mm)
 - max. 1-1/4"
 - max. (32 mm)

4. Maximum drilling distance

- Drilling distance center spindle: (-3/16") - 2-1/2" (-5mm) - 64 mm

5. Maximum drilling diameter

- Maximum drilling diameter: 1-3/8" (35 mm)

6. Accessories

- For accessories see BLUM catalog

2. Weight and measurements

- Weight: m = 81 lbs (37 kg)
- Dimensions:
 - H = 27-15/16" (710 mm)
 - W = 24" (610 mm)
 - D = 29-15/16" (760 mm)

Important:
 ! Provide a 16 A backup fuse breaker.





Appendix

i



L





i

Appendix



L





Appendix

i



L

 **blum**[®]

51



%%\$0,1,35(66)\$,G1US



\$0





i

Appendix



L

Subject to change without notice! IDNR: 598.608.0
BAU0004822774 IDX:01

BA63.02 EN-US / 08.06
Printed in Austria



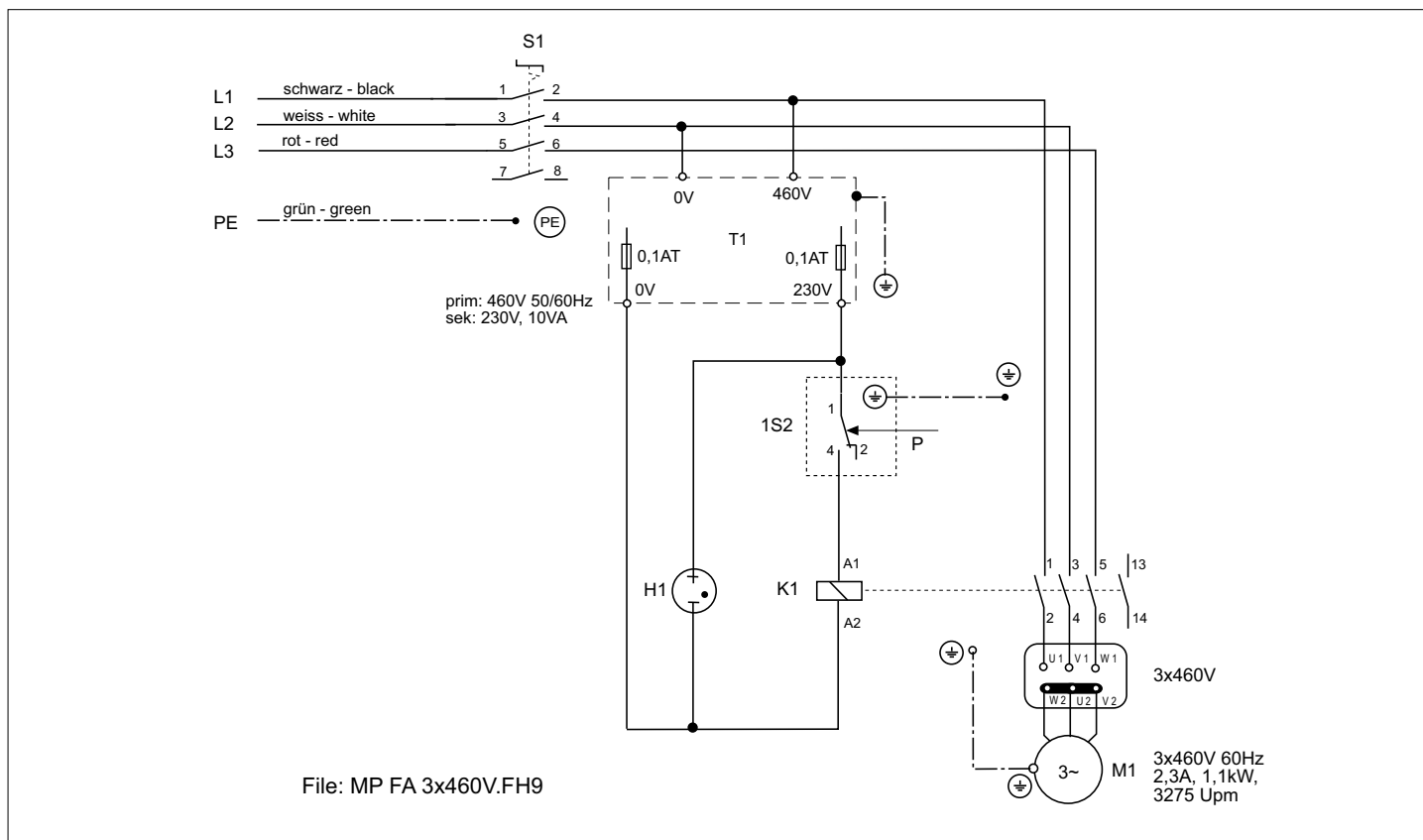

S1	690V IEC, 600V UL/CSA	4552380
T1	460V/230V, 15VA	5994850
F1, F2	250V, Ø5x20mm, 0,1AT	3809200
1S2	250V/6A, G1/4"	3988890
H1	230VAC	2456160
K1	400V (max.690V), 12A	2456300
M1	1,1kW, 3x460V	3282959

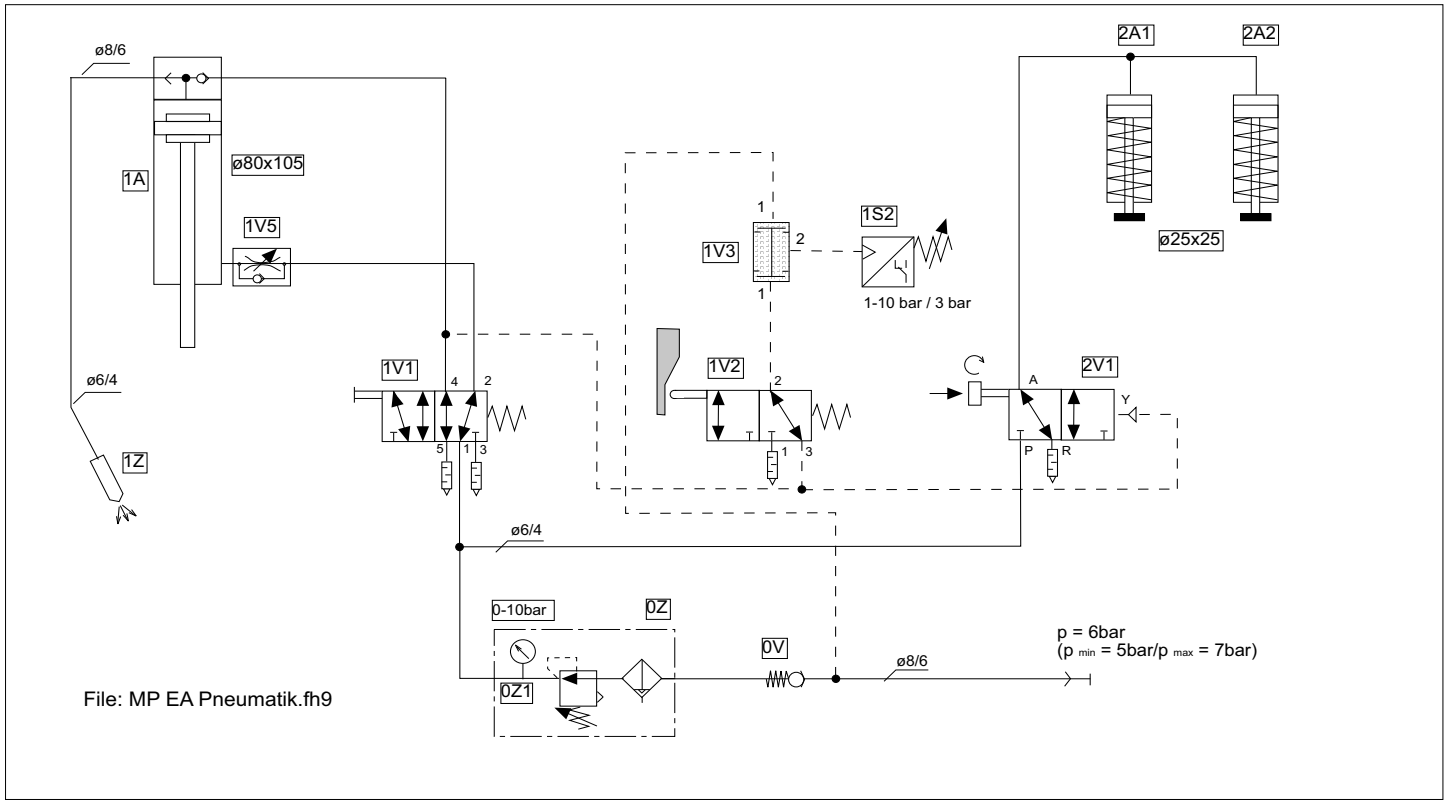

0	Gr.3	0474060
0V	G1/8"	1799490
0Z	G1/8", 5µm	3975560
0Z1	G1/8", DM40, 0-10	4398790
1A	G1/8"	2454384
1V1	G1/8"	8585365
1V2	M5	3976000
1V3	G1/8"	3988600
1V5	G1/8"	2454970
1S2	G1/4", 250V/6A	3988890
2V1	G1/8"	1800330
2A1	G1/8"	2285329 li/left
2A2	G1/8"	2285679 re/right

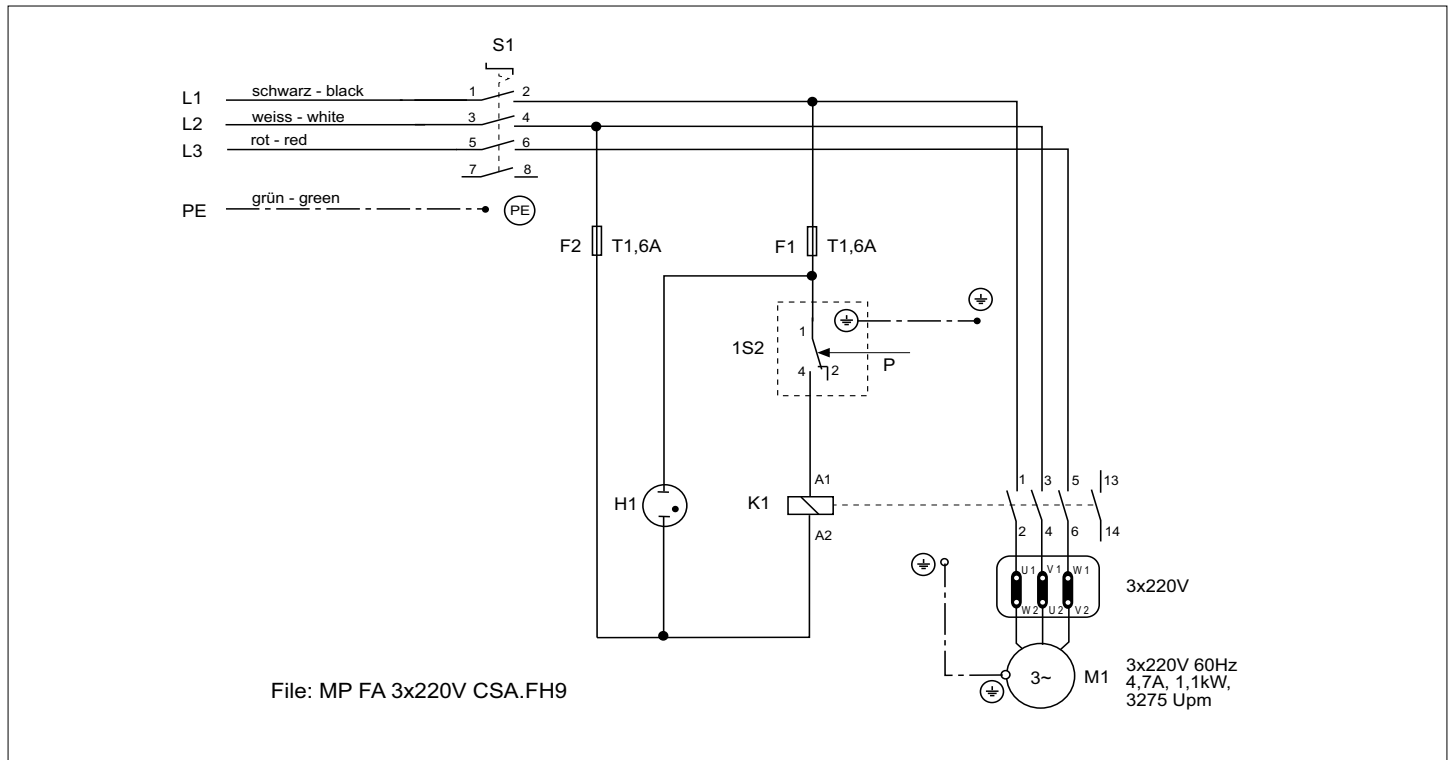

S1	690V IEC, 600V UL/CSA	4552380
F1, F2	250V, Ø5x20mm, 1,6AT	1788700
1S2	250V/6A, G1/4"	3988890
H1	230VAC	2456160
K1	400V (max.690V), 12A	2456300
M1	1,1kW, 3x220V	3247969

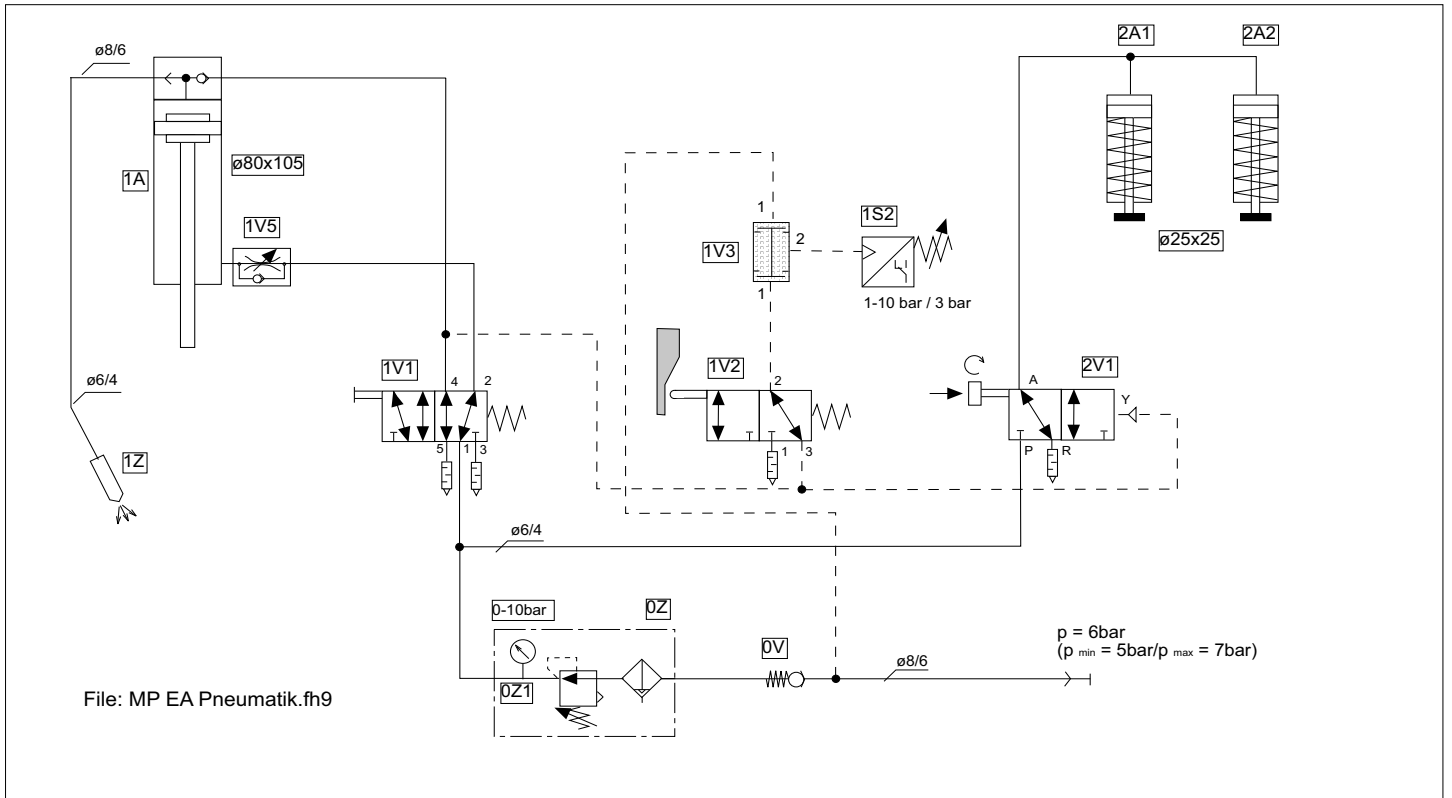

0	Gr.3	0474060
0V	G1/8"	1799490
0Z	G1/8", 5µm	3975560
0Z1	G1/8", DM40, 0-10	4398790
1A	G1/8"	2454384
1V1	G1/8"	8585365
1V2	M5	3976000
1V3	G1/8"	3988600
1V5	G1/8"	2454970
1S2	G1/4", 250V/6A	3988890
2V1	G1/8"	1800330
2A1	G1/8"	2285329 li/left
2A2	G1/8"	2285679 re/right

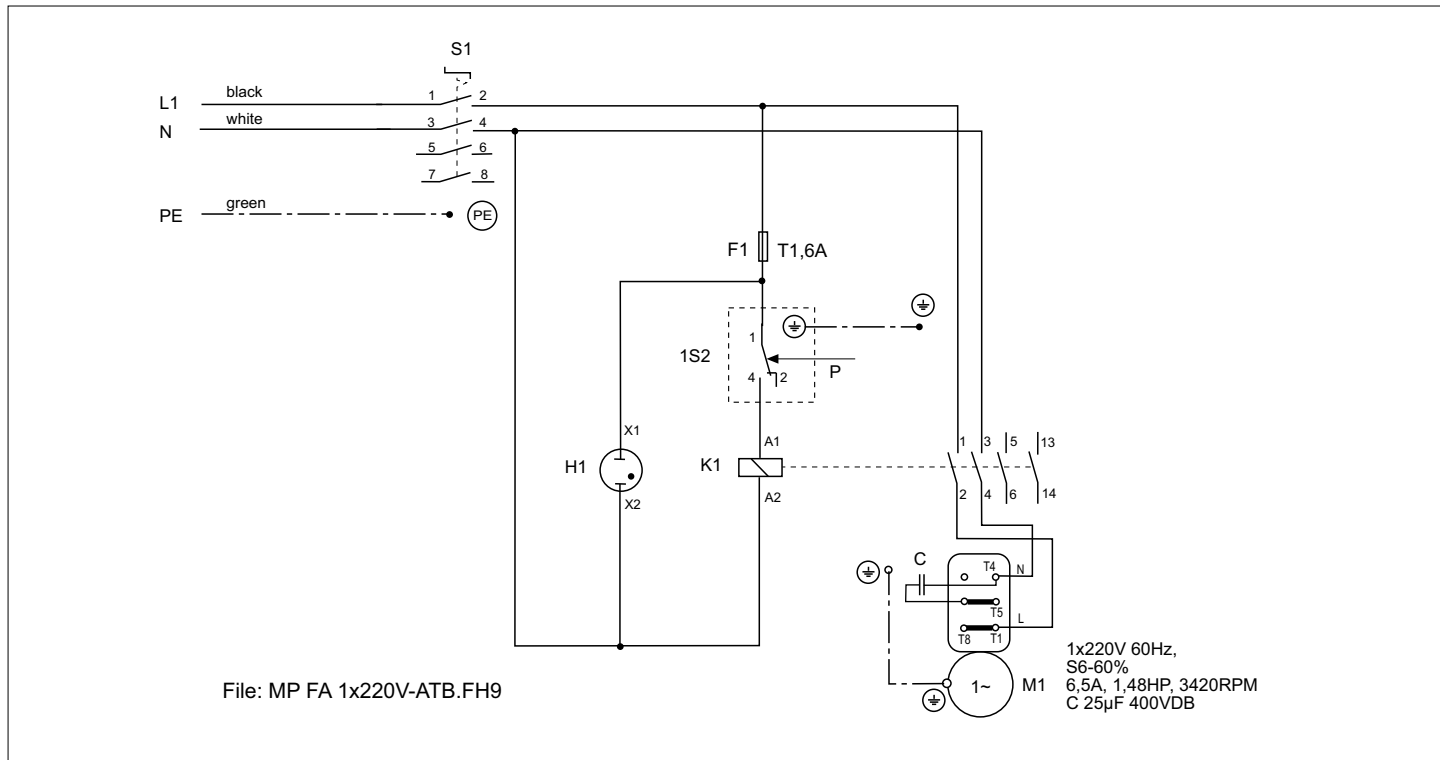

S1	690V IEC, 600V UL/CSA	4552380
F1	250V, Ø5x20mm, 1,6AT	1788700
1S2	250V/6A, G1/4"	3988890
H1	230VAC	2456160
K1	400V (max.690V), 12A	2456300
M1	1,1kW, 220V/60Hz	3244009
C	25µF, 400VDB	2649801

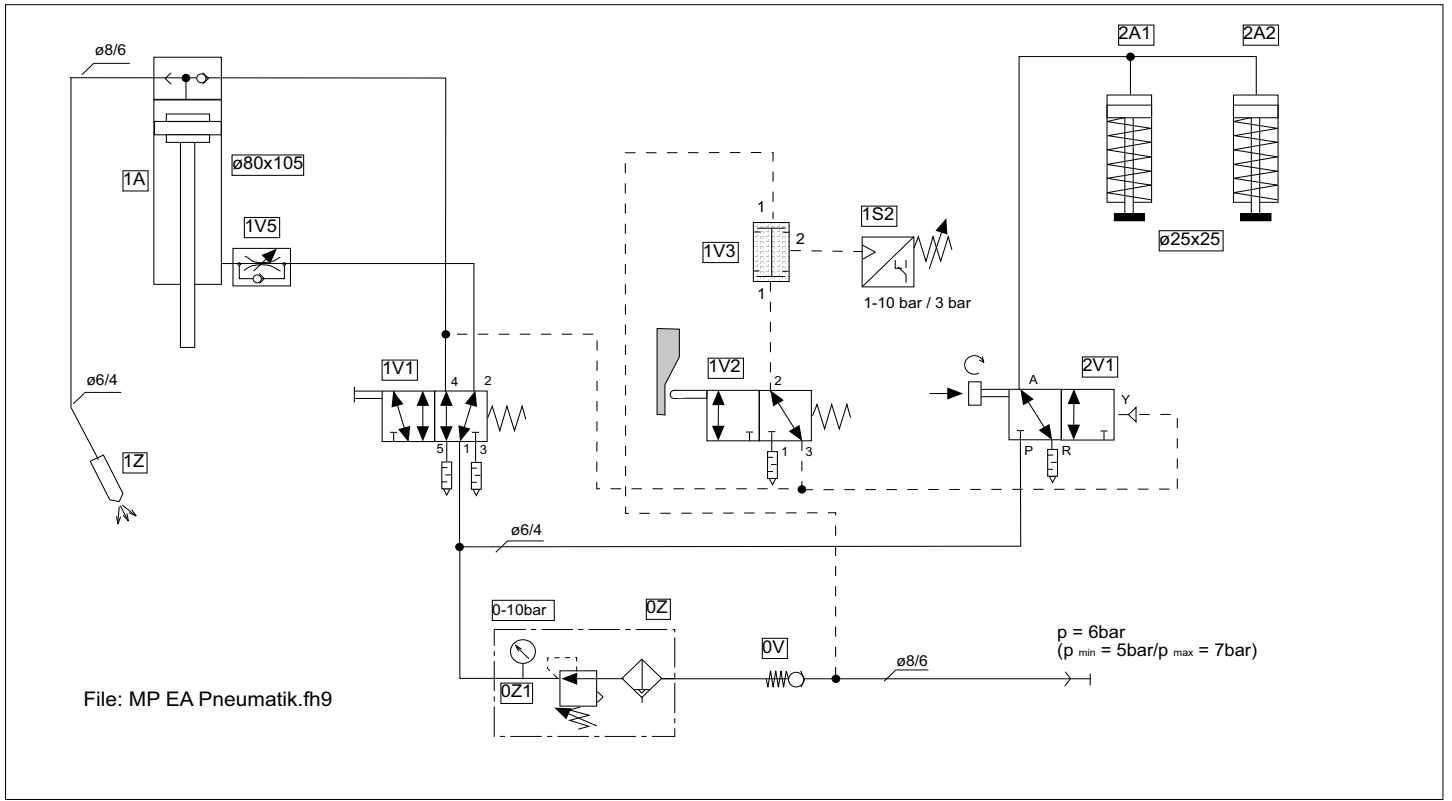

0	Gr.3	0474060
0V	G1/8"	1799490
0Z	G1/8", 5µm	3975560
0Z1	G1/8", DM40, 0-10	4398790
1A	G1/8"	2454384
1V1	G1/8"	8585365
1V2	M5	3976000
1V3	G1/8"	3988600
1V5	G1/8"	2454970
1S2	G1/4", 250V/6A	3988890
2V1	G1/8"	1800330
2A1	G1/8"	2285329 li/left
2A2	G1/8"	2285679 re/right

Blum, Inc.

7733 Old Plank Rd.
Stanley, NC 28164

toll free 800-438-6788

local 704-827-1345

fax 704-827-0799

internet www.blum.us

